

Made to Order ZP/ZP2 Series

Ø2 to Ø340

Compact/Short-type, Thin Flat, Bellows, High Rigidity

Model Selection

Compact/Short-type Ø2 to Ø15

Compact, Space saving

p. 304



Thin Flat Ø5 to Ø20

For the adsorption of soft workpieces such as thin sheets or vinyl

p. 312



Bellows Ø2 to Ø20

For use where there is no space for a buffer (spring type)

p. 314



High Rigidity Ø32 to Ø340

For heavy or large workpieces

p. 317



Made to Order

ZP2V

XT661

MHM











Pad Material: ZP/ZP2 Series

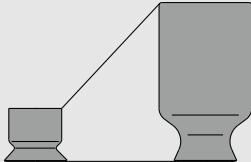





Material	NBR (Nitrile rubber)	Silicone rubber*1*2	Urethane rubber	FKM (Fluoro rubber)	CR (Chloroprene rubber)	EPDM (Ethylene propylene diene rubber)	Conductive NBR (Nitrile rubber)	Conductive silicone rubber
Color of rubber	Black	White	Brown	Black				
Rubber hardness (Shore A: ±5°)	50	40 to 50	55 to 60	60	50		50 to 65	45 to 60
Identification (Stamp)	—	—	—	Ⓕ	Ⓒ	Ⓔ	—	—

*1 Compliant with the FDA (USA Food and Drug Administration) regulation 21CFR§177.2600 for "Rubber articles intended for repeated use"

*2 Compliant with the standards for "Rubber apparatus (excluding baby drinking apparatus) and containers/packaging" (D3) (Partial revision: Ministry of Health, Labour, and Welfare Notification No. 595, 2012) in Section 3 "Apparatus and Containers/Packaging" of the Food Sanitation Act, Article 18 "Specifications and Standards for Food and Food Additives, etc." (Ministry of Health and Welfare Notification No. 370, 1959).

Precautions

Variations	Symbol	Pad		Page
		Form	Diameter	
Compact Pad Flat type For the adsorption of general workpieces For the adsorption of workpieces with flat, non-deformed surfaces Flat type with ribs For workpieces which are likely to deform or for the reliable release of workpieces Bellows type For the adsorption of workpieces with inclined surfaces	 Single unit U	Flat type	ø3, ø4	304
	 Single unit C	Flat type with ribs	ø6, ø7, ø8	304
	 Single unit B	Bellows type	ø6, ø8	304
Short-type Pad Space saving in the height direction 	 Single unit With adapter MU	Flat type	ø2, ø3.5 ø4, ø5, ø6 ø8, ø10 ø15	305
	 Single unit With adapter EU		ø2, ø4, ø6 ø8, ø15	308
	 Single unit AU		ø2, ø3, ø4 ø6, ø8	311
Thin Flat Pad For the adsorption of soft workpieces such as thin sheets or vinyl Wrinkling or deformation during adsorption is reduced.	 Single unit UT	Thin flat type (Skirt)	ø5, ø6, ø11 ø14, ø18 ø20	312
Bellows Pad For use where there is no space for a buffer (spring type) For the adsorption of workpieces with inclined surfaces 	 Single unit With adapter MB	Bellows type	ø4, ø6, ø8 ø10, ø15 ø20	314
	 Single unit ZJ		ø2, ø4 ø5, ø6	316

Variations	Symbol	Pad		Page
		Form	Diameter	
Blast-type Pad Features blast treatment to create fine unevenness on the surface for improved adsorption Workpieces can be removed easily.	 Single unit U	Flat type	ø4	304
	 Single unit C	Flat type with ribs	ø6, ø8	304
	 Single unit B	Bellows type	ø6, ø8	304
	 Single unit With adapter MU	Flat type	ø2, ø3.5 ø4, ø5, ø6 ø8, ø10 ø15	305
	 Single unit With adapter EU	Flat type	ø2, ø4, ø6	308
	 Single unit AU	Flat type	ø8	311
	 Single unit With adapter MB	Bellows type	ø4, ø6, ø8 ø10, ø15 ø20	314

Model Selection











Made to Order







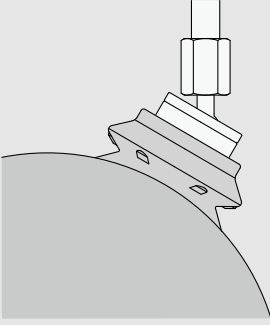

ZP2V

XT661

MHM

Precautions

Variations	Symbol	Pad		Page
		Form	Diameter	
<p>High Rigidity Pad</p> <p>High rigidity (Flat type with ribs) Ideal for heavy or large workpieces such as CRT tubes and automobile bodies</p> <p>High rigidity (Bellows type) · Ideal for workpieces with curved surfaces · Ideal for heavy or large workpieces</p>	H	High rigidity (Flat type with ribs)	ø40, ø50 ø63, ø80 ø100, ø125	 Single unit 333
				 With adapter: Vacuum inlet direction Vertical 334
				 With adapter: Vacuum inlet direction Lateral 337
				 With buffer: Vacuum inlet direction Vertical 339
				 With buffer: Vacuum inlet direction Lateral 341
	HB	High rigidity (Bellows type)	ø40, ø50 ø63, ø80 ø100, ø125	 Single unit 333
				 With adapter: Vacuum inlet direction Vertical 334
				 With adapter: Vacuum inlet direction Lateral 337
				 With buffer: Vacuum inlet direction Vertical 339
				 With buffer: Vacuum inlet direction Lateral 341

Variations	Symbol	Pad		Page	
		Form	Diameter		
<p>High Rigidity Ball Joint Pad For the adsorption of workpieces with inclined or curved surfaces</p> 	 <p>With adapter: Vacuum inlet direction Vertical</p>	H	High rigidity (Flat type with ribs)	321	
				 <p>With adapter: Vacuum inlet direction Lateral</p>	322
				 <p>With buffer: Vacuum inlet direction Vertical</p>	323 ∅40 ∅50 ∅63 ∅80 ∅100 ∅125
				 <p>With buffer: Vacuum inlet direction Lateral</p>	325
	HB	 <p>With adapter: Vacuum inlet direction Vertical</p>	High rigidity (Bellows type)	327	
				 <p>With adapter: Vacuum inlet direction Lateral</p>	328
		 <p>With buffer: Vacuum inlet direction Vertical</p>		329 ∅40 ∅50 ∅63 ∅80 ∅100 ∅125	
		 <p>With buffer: Vacuum inlet direction Lateral</p>		331	

Model Selection





Made to Order

ZP2V

XT661

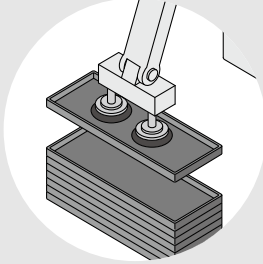
MHM

Precautions

Variations	Symbol	Pad		Page	
		Form	Diameter		
High Rigidity Pad For heavy or large workpieces 		H	High rigidity (Flat type with ribs)	ø32, ø300 ø340	317
		HT	High rigidity (Thin flat type with ribs)	ø150, ø250	317
		HB	High rigidity (Bellows type)	ø32, ø150	319
		HW	High rigidity (Oval type)	30 x 50	320



Compact Pad

Pad diameter $\varnothing 3, \varnothing 4, \varnothing 6, \varnothing 7, \varnothing 8$

Symbol/Form

U: Flat type
C: Flat type with ribs
B: Bellows type

Model Selection

- 5 types of $\varnothing 3$ to $\varnothing 8$ are added.
- Applicable for the ZP series adapter

Mounting Bracket Part Nos.

Adapter Assembly p. 313

How to Order

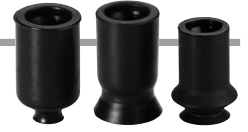

Pad unit **ZP2-03UN**

* Pad unit's sales unit: 10 pcs.
Except bellows type

Pad diameter		
Symbol	Pad diameter	Blast type
03	$\varnothing 3$	—
B04	$\varnothing 4$	●
B06	$\varnothing 6$	●
07	$\varnothing 7$	—
B08	$\varnothing 8$	●

* Blast type: Workpieces can be removed easily.

Pad material

Symbol	Material
N	NBR
S	Silicone rubber*1
U	Urethane rubber
F	FKM
GN	Conductive NBR
GS	Conductive silicone rubber

*1 Compliant with the FDA (USA Food and Drug Administration) regulation 21CFR§177.2600 for "Rubber articles intended for repeated use"

Pad form—Pad diameter

Pad form	Pad diameter (Symbol)				
	03	B04	B06	07	B08
U (Flat type)	●	●	—	—	—
C (Flat type with ribs)	—	—	—	●	●
B (Bellows type)	—	—	●	—	●

Made to Order

ZP2V

XT661

MHM

Dimensions: Pad Unit

ZP2-03U□

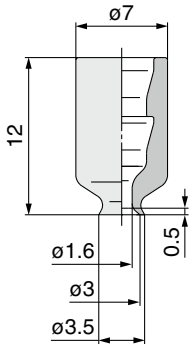

ZP2-B04U□

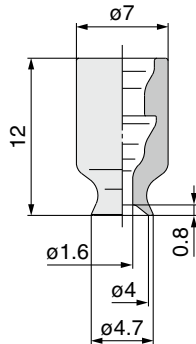

ZP2-B06B□

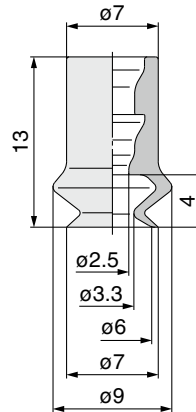

ZP2-B08B□

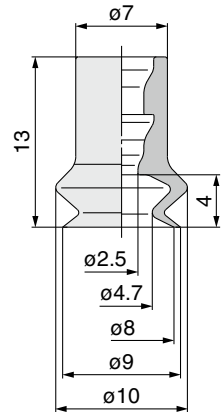

ZP2-B06C□

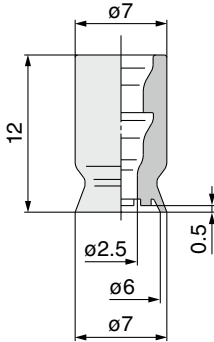

ZP2-07C□

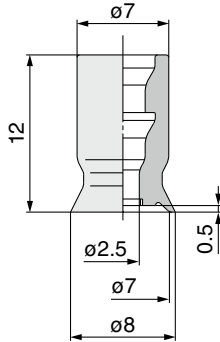

ZP2-B08C□

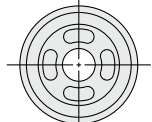
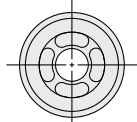
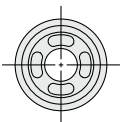
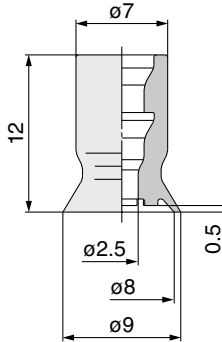

Adapter Mounting Dimensions

If an adapter will be made by the customer, design the adapter with the dimensions shown below.

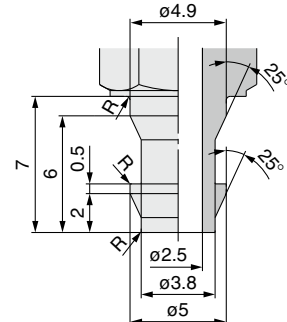

* The R part has to be smooth with no corners.

Precautions

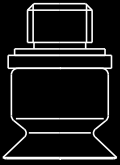

Short-type Pad

Symbol/Form

Pad diameter $\varnothing 2, \varnothing 3.5, \varnothing 4, \varnothing 5, \varnothing 6, \varnothing 8, \varnothing 10, \varnothing 15$

MU: Flat type

Space saving in the height direction

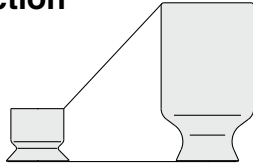

How to Order



Pad unit **ZP2 – B02 MU N**

* Pad unit's sales unit: 10 pcs.

Pad diameter

Symbol	Pad diameter	Blast type
B02	$\varnothing 2$	●
B035	$\varnothing 3.5$	●
B04	$\varnothing 4$	●
B05	$\varnothing 5$	●
B06	$\varnothing 6$	●
B08	$\varnothing 8$	●
B10	$\varnothing 10$	●
B15	$\varnothing 15$	●

* Blast type: Workpieces can be removed easily.

Pad material

Symbol	Material
N	NBR
S	Silicone rubber*1
U	Urethane rubber
F	FKM
GN	Conductive NBR
GS	Conductive silicone rubber

*1 Compliant with the FDA (USA Food and Drug Administration) regulation 21CFR§177.2600 for "Rubber articles intended for repeated use"

Pad form

Symbol	Form
MU	Flat type

Dimensions: Pad Unit

ZP2-B02MU□

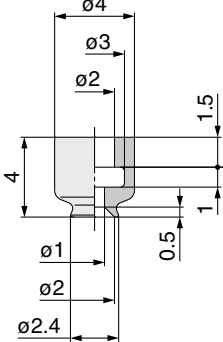

ZP2-B035MU□

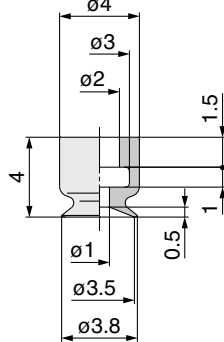

ZP2-B04MU□

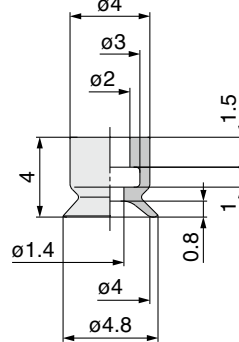

ZP2-B05MU□

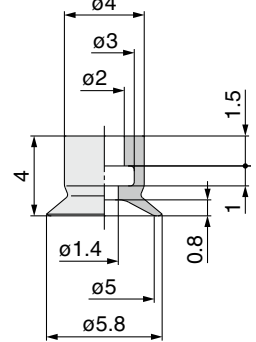

ZP2-B06MU□

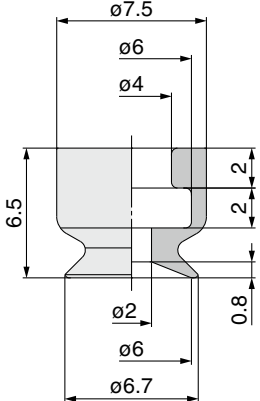

ZP2-B08MU□

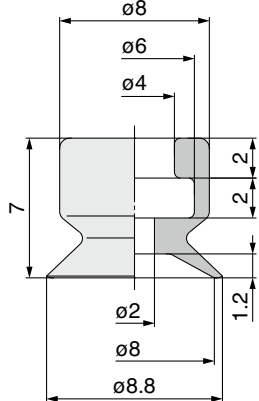

ZP2-B10MU□

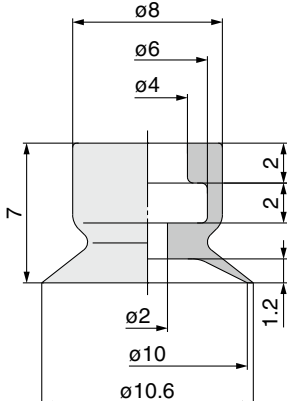

ZP2-B15MU□

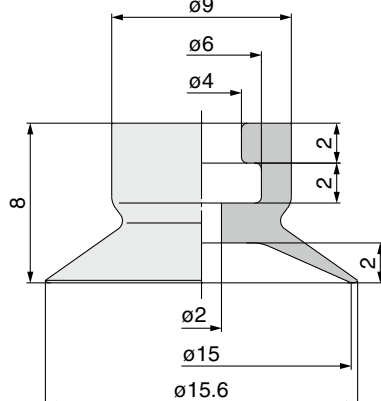

Adapter Mounting Dimensions

If an adapter will be made by the customer, design the adapter with the dimensions shown below.

Applicable pad
B02MU/B035MU/B04MU/B05MU

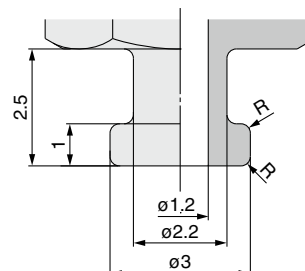

Applicable pad
B06MU/B08MU/B10MU/B15MU

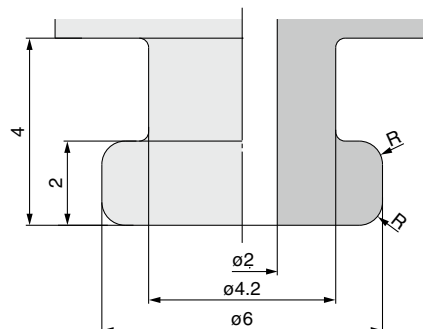

* The R part has to be smooth with no corners.
* Refer to page 306 for adapter applicable to the ZP2 series.

Model Selection



How to Order

With adapter **ZP2 - T B02 MU N - A3**

Vacuum inlet direction

Symbol	Direction
T	Vertical

Pad diameter

Symbol	Pad diameter	Blast type
B02	ø2	●
B035	ø3.5	●
B04	ø4	●
B05	ø5	●
B06	ø6	●
B08	ø8	●
B10	ø10	●
B15	ø15	●

* Blast type: Workpieces can be removed easily.

Pad form

Symbol	Form
MU	Flat type

Mounting

Thread size	Pad diameter (Symbol)	B02	B035	B04	B05	B06	B08	B10	B15
A3 (M3 x 0.5 Male thread)		●	●	●	●	—	—	—	—
H5 (M5 x 0.8 Male thread)		—	—	—	—	●	●	●	●
B5 (M5 x 0.8 Female thread)		—	—	—	—	●	●	●	●

Pad material

Symbol	Material
N	NBR
S	Silicone rubber*1
U	Urethane rubber
F	FKM
GN	Conductive NBR
GS	Conductive silicone rubber

*1 Compliant with the FDA (USA Food and Drug Administration) regulation 21CFR§177.2600 for "Rubber articles intended for repeated use"

Replacement Part Nos.

Model	Pad unit part no.*1	Adapter part no. (With gasket)	Gasket part no. (Single unit)
ZP2-TB02MU□-A3	ZP2-B02MU□	ZP2A-M01P	M-3G2
ZP2-TB035MU□-A3	ZP2-B035MU□		
ZP2-TB04MU□-A3	ZP2-B04MU□		
ZP2-TB05MU□-A3	ZP2-B05MU□		
ZP2-TB06MU□-H5	ZP2-B06MU□	ZP2A-M02P	10 pcs.*2: ZP-5G2 100 pcs.*2: M-5G2
ZP2-TB08MU□-H5	ZP2-B08MU□		
ZP2-TB10MU□-H5	ZP2-B10MU□		
ZP2-TB15MU□-H5	ZP2-B15MU□	ZP2A-M04	—
ZP2-TB06MU□-B5	ZP2-B06MU□		
ZP2-TB08MU□-B5	ZP2-B08MU□		
ZP2-TB10MU□-B5	ZP2-B10MU□		
ZP2-TB15MU□-B5	ZP2-B15MU□		

*1 Pad unit's sales unit: 10 pcs.

*2 The gasket (single unit) sales unit is shown.

* □ in the table indicates the pad material

* The pad is shipped together but does not come assembled.

Made to Order

ZP2V

XT661

MHM

Dimensions: With Adapter

ZP2-TB02MU□-A3

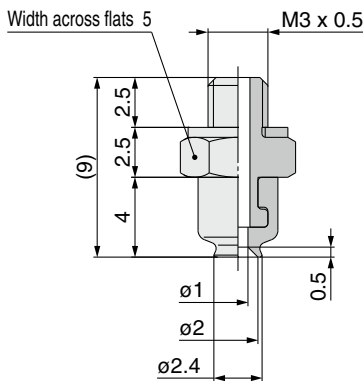

ZP2-TB035MU□-A3

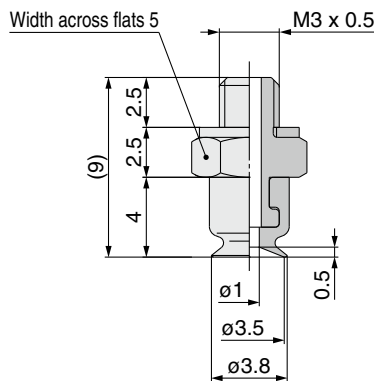

ZP2-TB04MU□-A3

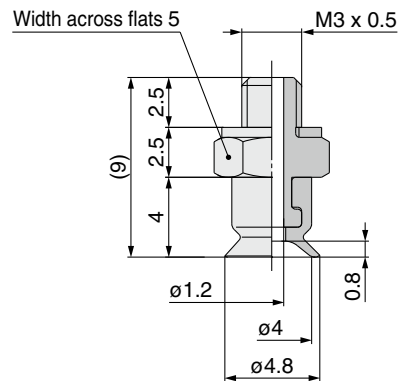

ZP2-TB05MU□-A3

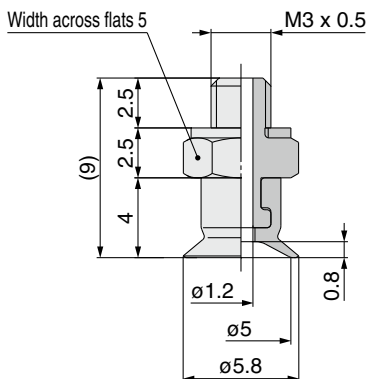

ZP2-TB06MU□-H5

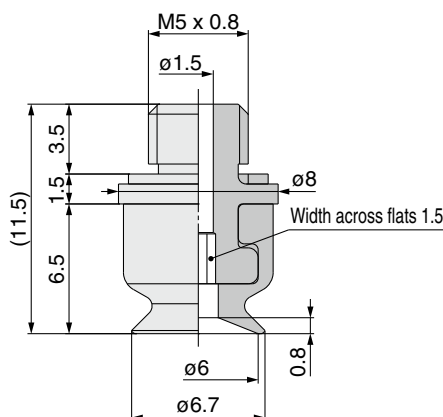

ZP2-TB08MU□-H5

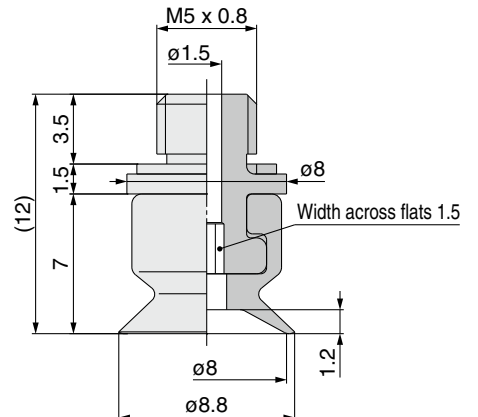

Precautions

Dimensions: With Adapter

ZP2-TB10MU□-H5

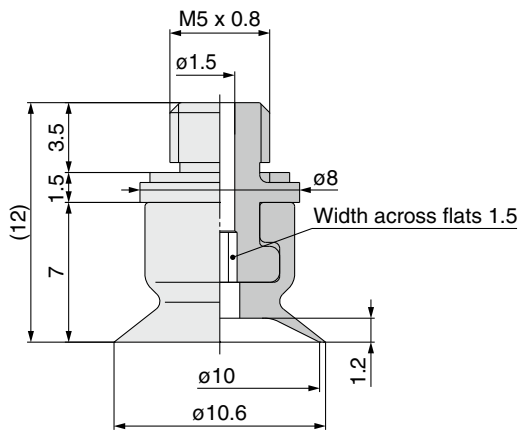

ZP2-TB15MU□-H5

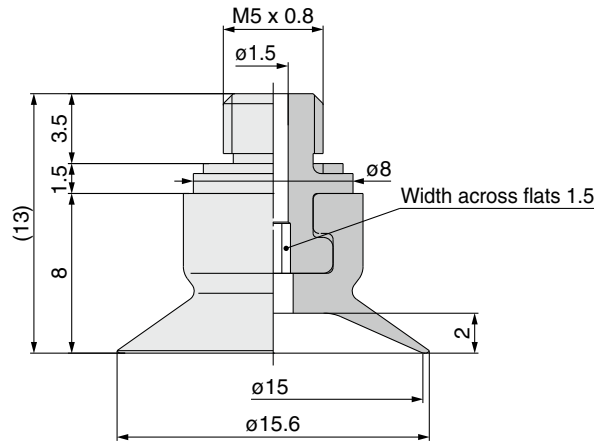

ZP2-TB06MU□-B5

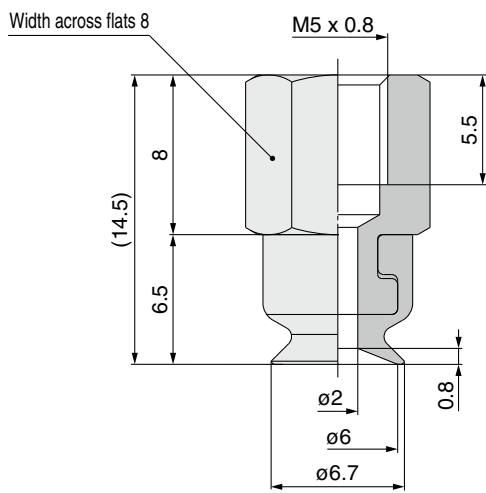

ZP2-TB08MU□-B5

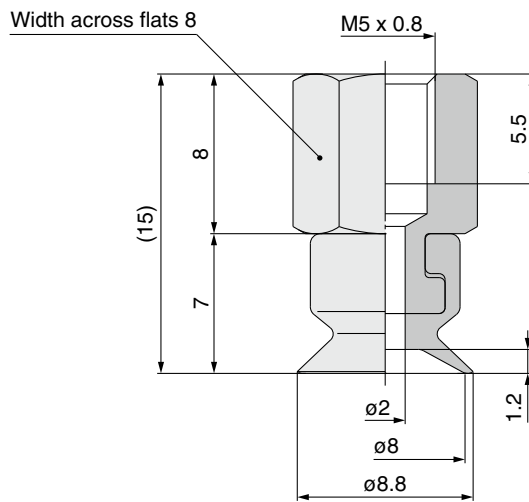

ZP2-TB10MU□-B5

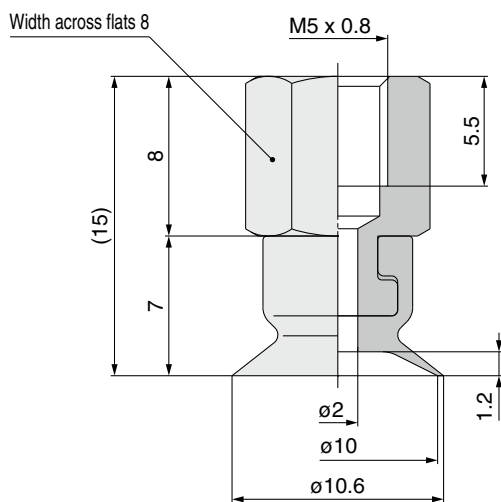

ZP2-TB15MU□-B5

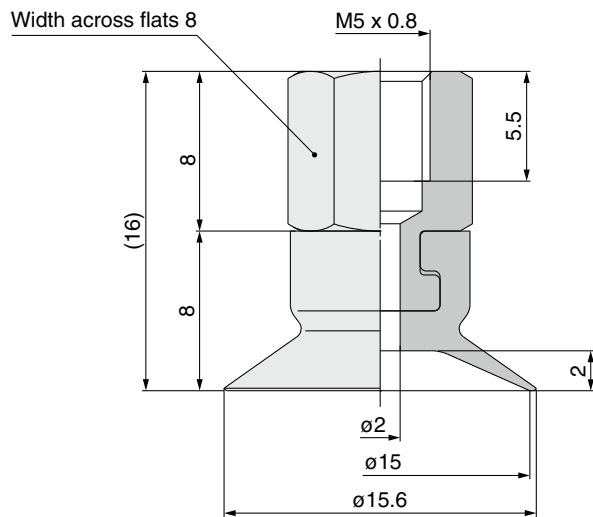

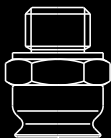

Short-type Pad

Symbol/Form

Pad diameter $\phi 2, \phi 4, \phi 6, \phi 8, \phi 15$

EU: Flat type

Model Selection

Space saving in the height direction

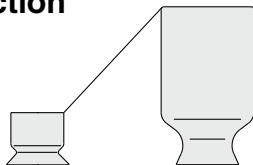

How to Order



Pad unit **ZP2 - B02 EU N**

* Pad unit's sales unit: 10 pcs.

Pad diameter		
Symbol	Pad diameter	Blast type
B02	$\phi 2$	●
B04	$\phi 4$	●
B06	$\phi 6$	●
08	$\phi 8$	—
15	$\phi 15$	—

* Blast type: Workpieces can be removed easily.

Pad material

Symbol	Material
N	NBR
S	Silicone rubber*1
U	Urethane rubber
F	FKM
GN	Conductive NBR
GS	Conductive silicone rubber

*1 Compliant with the FDA (USA Food and Drug Administration) regulation 21CFR§177.2600 for "Rubber articles intended for repeated use"

Pad form

Symbol	Form
EU	Flat type

Dimensions: Pad Unit

ZP2-B02EU□

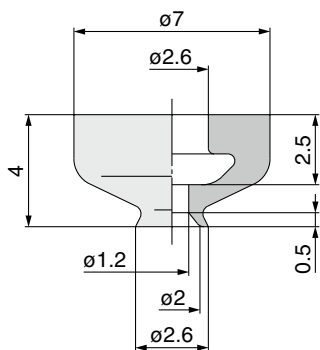

ZP2-B04EU□

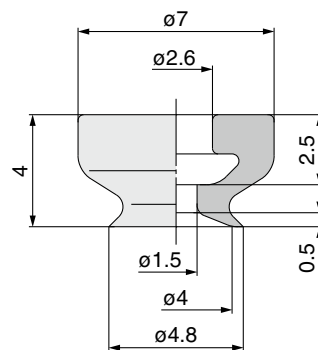

ZP2-B06EU□

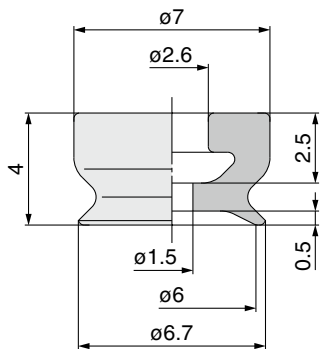

ZP2-08EU□

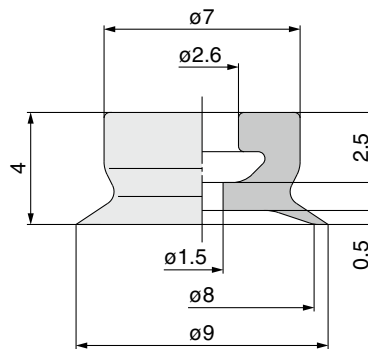

ZP2-15EU□

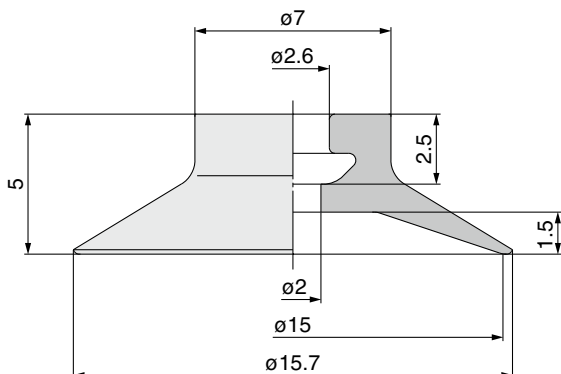

Adapter Mounting Dimensions

If an adapter will be made by the customer, design the adapter with the dimensions shown below.

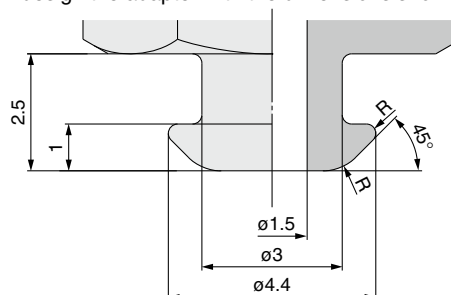

* The R part has to be smooth with no corners.
* Refer to page 309 for adapter applicable to the ZP2 series.

Made to Order

ZP2V

XT661

MHM

Precautions

Short-type Pad **ZP2 Series**

How to Order

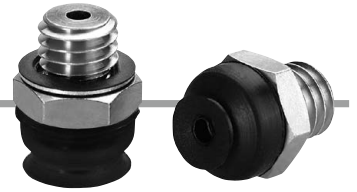

With adapter **ZP2 - T B02 EU N - A5**

Vacuum inlet direction

Symbol	Direction
T	Vertical

Pad diameter

Symbol	Pad diameter	Blast type
B02	ø2	●
B04	ø4	●
B06	ø6	●
08	ø8	—
15	ø15	—

* Blast type: Workpieces can be removed easily.

Pad form

Symbol	Form
EU	Flat type

Mounting

Symbol	Thread size	Adapter type
A5	M5 x 0.8	Hexagon O.D.
H5	M5 x 0.8	Hexagon socket head

Pad material

Symbol	Material
N	NBR
S	Silicone rubber*1
U	Urethane rubber
F	FKM
GN	Conductive NBR
GS	Conductive silicone rubber

*1 Compliant with the FDA (USA Food and Drug Administration) regulation 21CFR§177.2600 for "Rubber articles intended for repeated use"

Replacement Part Nos.

Model	Pad unit part no.*1	Adapter part no. (With gasket)	Gasket part no. (Single unit)
ZP2-TB02EU□-A5	ZP2-B02EU□	ZP2A-Z01P	10 pcs.*2: ZP-5G2 100 pcs.*2: M-5G2
ZP2-TB04EU□-A5	ZP2-B04EU□		
ZP2-TB06EU□-A5	ZP2-B06EU□	ZP2A-Z02P	10 pcs.*2: ZP-5G2 100 pcs.*2: M-5G2
ZP2-T08EU□-A5	ZP2-08EU□		
ZP2-T15EU□-A5	ZP2-15EU□		
ZP2-TB02EU□-H5	ZP2-B02EU□	ZP2A-Z01P	10 pcs.*2: ZP-5G2 100 pcs.*2: M-5G2
ZP2-TB04EU□-H5	ZP2-B04EU□		
ZP2-TB06EU□-H5	ZP2-B06EU□	ZP2A-Z02P	10 pcs.*2: ZP-5G2 100 pcs.*2: M-5G2
ZP2-T08EU□-H5	ZP2-08EU□		
ZP2-T15EU□-H5	ZP2-15EU□		

*1 Pad unit's sales unit: 10 pcs.

*2 The gasket (single unit) sales unit is shown.

* □ in the table indicates the pad material

* The pad is shipped together but does not come assembled.

Dimensions: With Adapter

ZP2-TB02EU□-A5

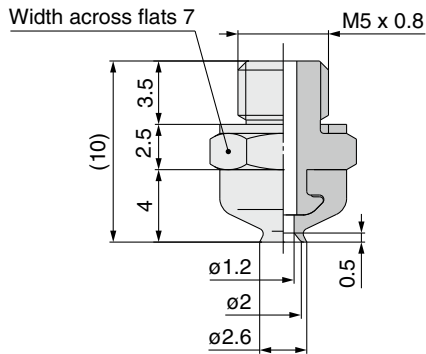

ZP2-TB04EU□-A5

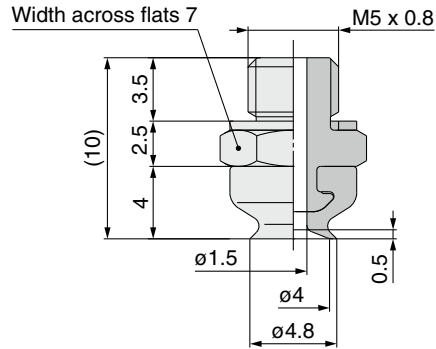

ZP2-TB06EU□-A5

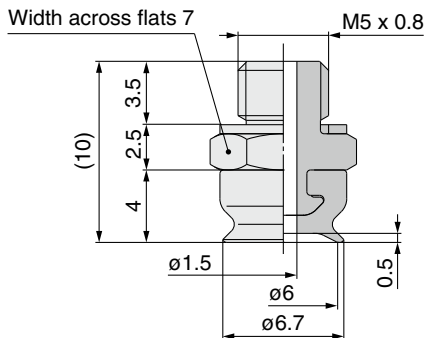

ZP2-T08EU□-A5

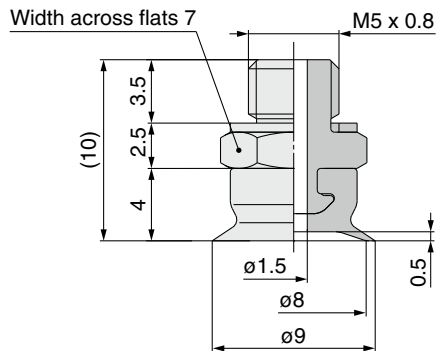

ZP2-T15EU□-A5

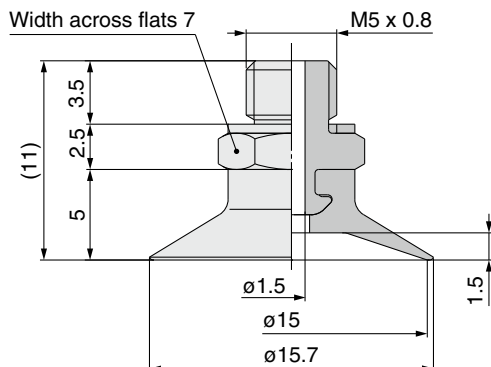

Dimensions: With Adapter

ZP2-TB02EU□-H5

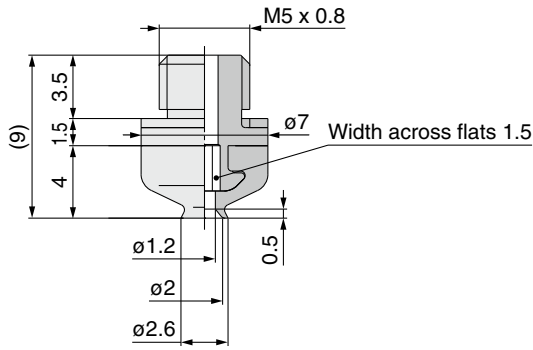

ZP2-TB04EU□-H5

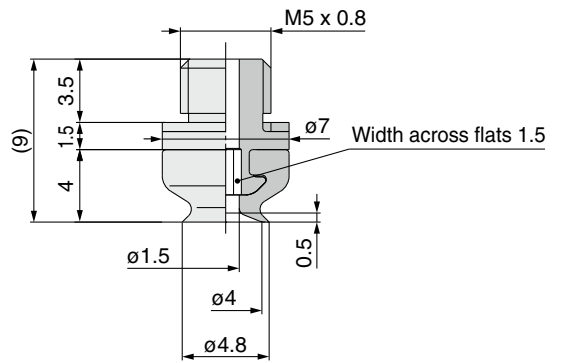

ZP2-TB06EU□-H5

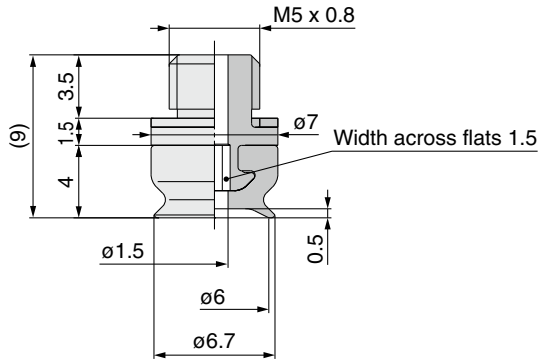

ZP2-T08EU□-H5

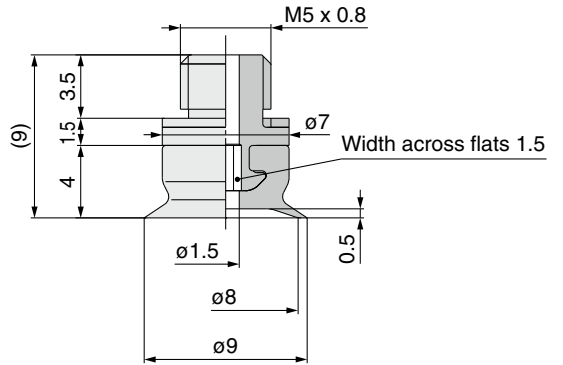

ZP2-T15EU□-H5

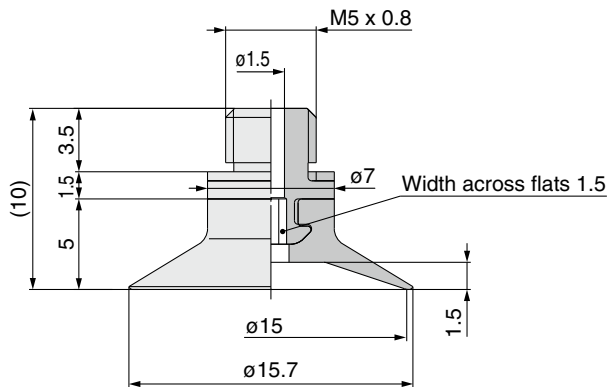

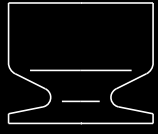

Short-type Pad

Symbol/Form

Pad diameter $\varnothing 2, \varnothing 3, \varnothing 4, \varnothing 6, \varnothing 8$

AU: Flat type

Space saving in the height direction

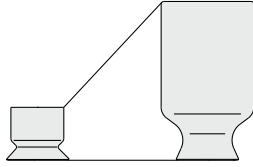

* The mounting adapter is available as a special order.

How to Order



Pad unit **ZP2-02AU N**

* Pad unit's sales unit: 10 pcs.

Pad diameter

Symbol	Pad diameter	Blast type
02	$\varnothing 2$	—
03	$\varnothing 3$	—
04	$\varnothing 4$	—
06	$\varnothing 6$	—
B08	$\varnothing 8$	●

* Blast type: Workpieces can be removed easily.

Pad material

Symbol	Material
N	NBR
S	Silicone rubber*1
U	Urethane rubber
F	FKM
GN	Conductive NBR
GS	Conductive silicone rubber

*1 Compliant with the FDA (USA Food and Drug Administration) regulation 21CFR§177.2600 for "Rubber articles intended for repeated use"

Pad form

Symbol	Form
AU	Flat type

Dimensions: Pad Unit

ZP2-02AU□

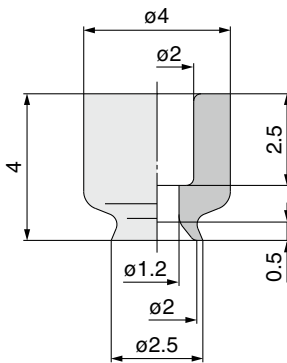

ZP2-03AU□

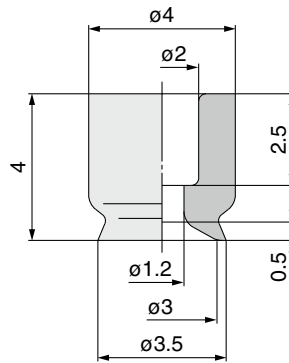

ZP2-04AU□

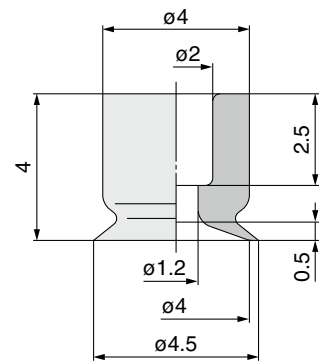

ZP2-06AU□

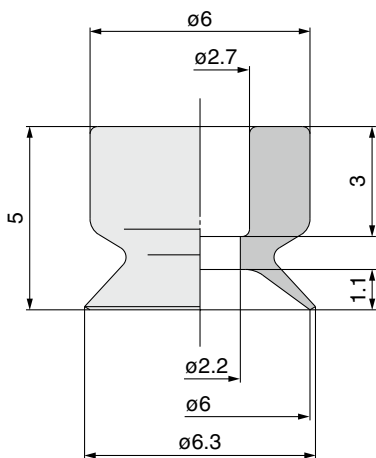

ZP2-B08AU□

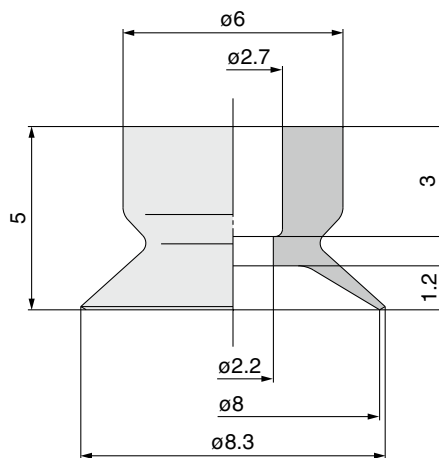

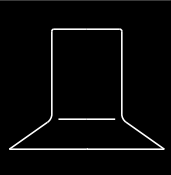

Thin Flat Pad

Symbol/Form

UT: Thin flat type (Skirt)

Pad diameter $\varnothing 5, \varnothing 6, \varnothing 11, \varnothing 14, \varnothing 18, \varnothing 20$

Model Selection

■ For the adsorption of soft workpieces such as thin sheets or vinyl Wrinkling or deformation during adsorption is reduced.

■ Applicable for the ZP series adapter

Mounting Bracket Part Nos.

Adapter Assembly p. 313

How to Order

Pad unit **ZP2-11 UT N**

* Pad unit's sales unit: 10 pcs.

Pad diameter

Symbol	Pad diameter
05	$\varnothing 5$
06	$\varnothing 6$
11	$\varnothing 11$
14	$\varnothing 14$
18	$\varnothing 18$
20	$\varnothing 20$

Pad form

Symbol	Form
UT	Thin flat type (Skirt)

Pad material

Symbol	Material
N	NBR
S	Silicone rubber*1
U	Urethane rubber
F	FKM
GN	Conductive NBR
GS	Conductive silicone rubber

*1 Compliant with the FDA (USA Food and Drug Administration) regulation 21CFR§177.2600 for "Rubber articles intended for repeated use"



Made to Order

Dimensions: Pad Unit

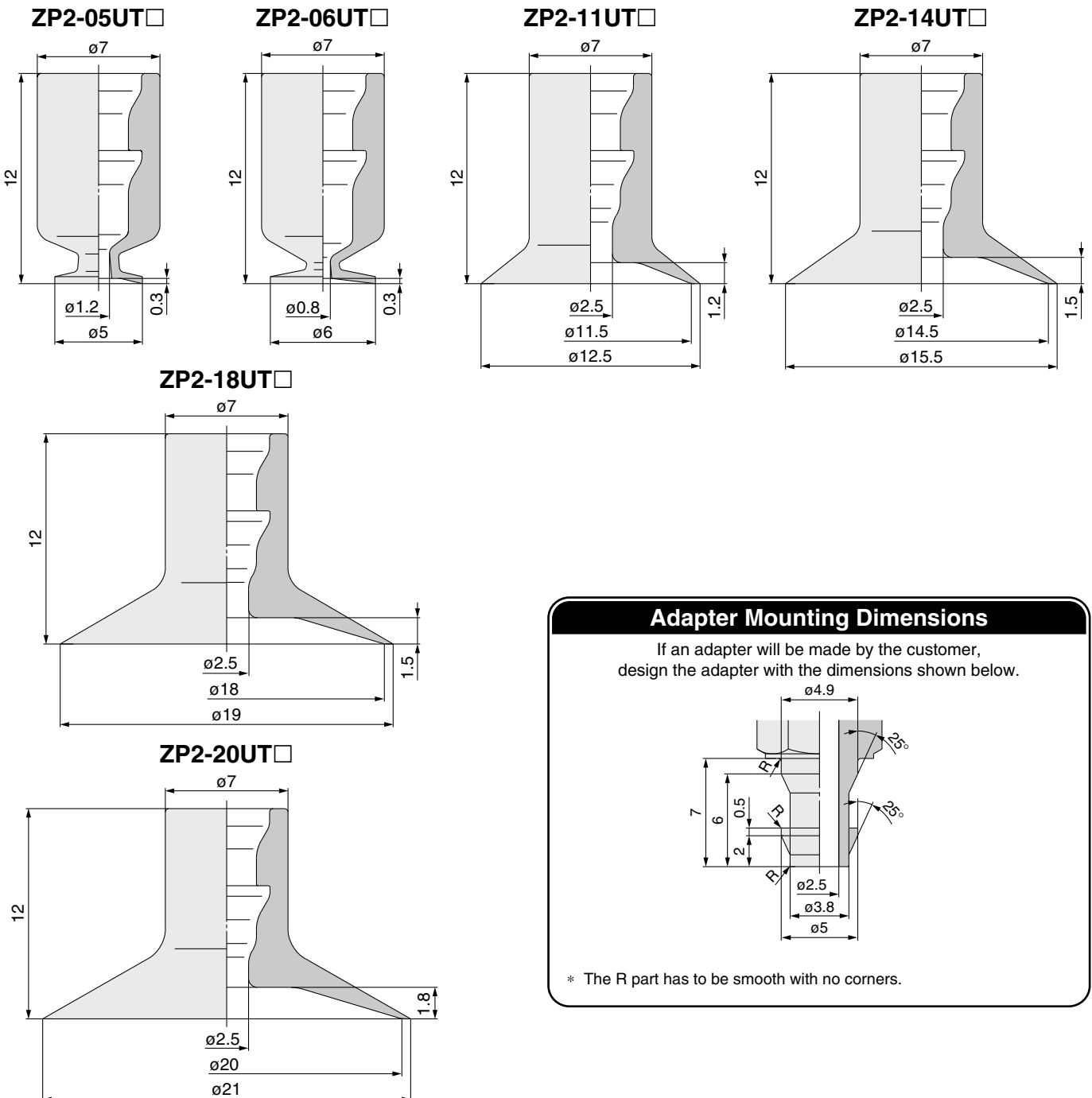

Adapter Mounting Dimensions

If an adapter will be made by the customer, design the adapter with the dimensions shown below.

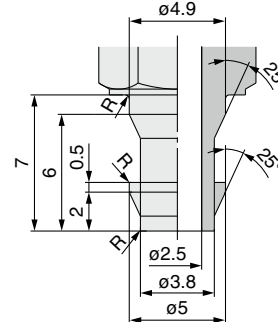

* The R part has to be smooth with no corners.

ZP2V

XT661

MHM

Precautions

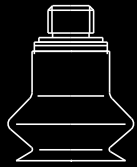

Bellows Pad

Symbol/Form

Pad diameter $\varnothing 4, \varnothing 6, \varnothing 8, \varnothing 10, \varnothing 15, \varnothing 20$

MB: Bellows type

Model Selection

- For use where there is no space for a buffer (spring type)
- For the adsorption of workpieces with inclined surfaces

How to Order

Pad unit **ZP2 - B04 MB N**



Symbol	Pad diameter	Blast type
B04	$\varnothing 4$	●
B06	$\varnothing 6$	●
B08	$\varnothing 8$	●
B10	$\varnothing 10$	●
B15	$\varnothing 15$	●
B20	$\varnothing 20$	●

Symbol	Form
MB	Bellows type

Pad material

Symbol	Material
N	NBR
S	Silicone rubber*1
U	Urethane rubber
F	FKM
GN	Conductive NBR
GS	Conductive silicone rubber

*1 Compliant with the FDA (USA Food and Drug Administration) regulation 21CFR§177.2600 for "Rubber articles intended for repeated use"

* Blast type: Workpieces can be removed easily.

Dimensions: Pad Unit

ZP2-B04MB □

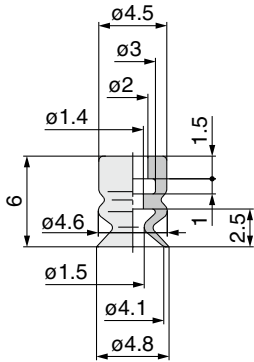

ZP2-B06MB □

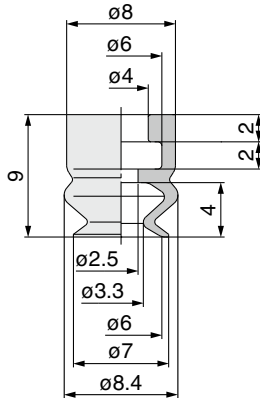

ZP2-B08MB □

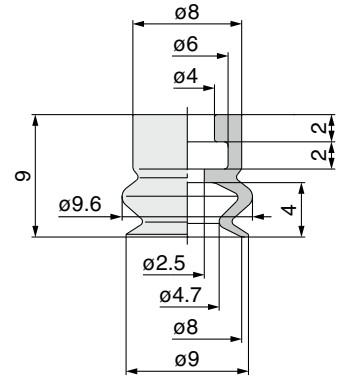

ZP2-B10MB □

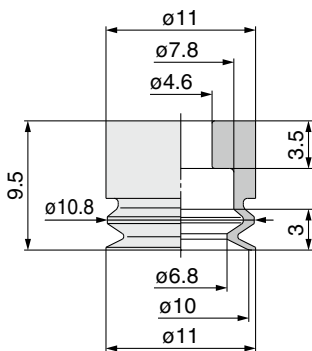

ZP2-B15MB □

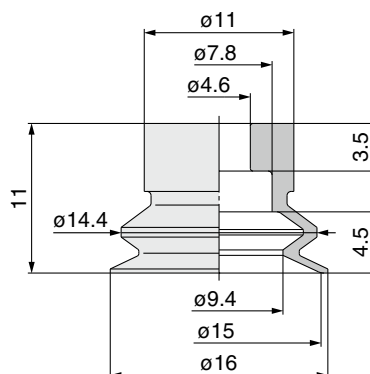

ZP2-B20MB □

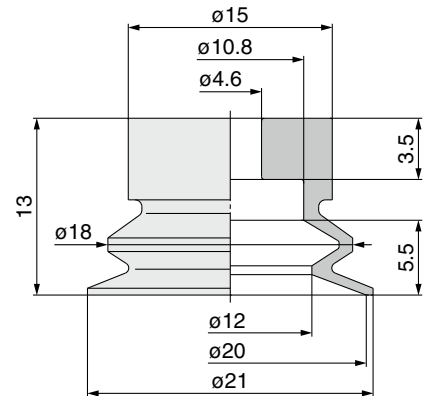

Adapter Mounting Dimensions

If an adapter will be made by the customer, design the adapter with the dimensions shown below.

Applicable pad B04MB

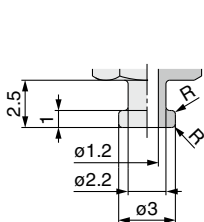

Applicable pad B06MB/B08MB

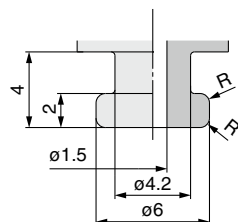

Applicable pad B10MB/B15MB

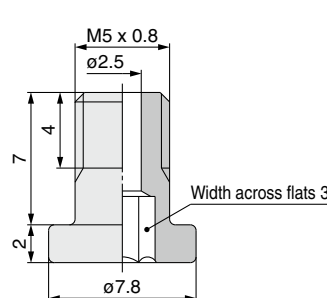

Applicable pad B20MB

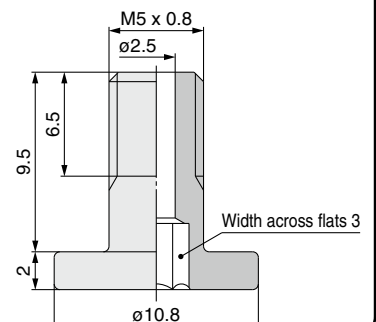

* The R part has to be smooth with no corners.
* Refer to page 315 for adapter applicable to the ZP2 series.

Made to Order

ZP2V

XT661

MHM

Precautions

How to Order



With adapter **ZP2 - T B04 MB N - A3**

Vacuum inlet direction

Symbol	Direction
T	Vertical

Pad diameter

Symbol	Pad diameter	Blast type
B04	ø4	●
B06	ø6	●
B08	ø8	●
B10	ø10	●
B15	ø15	●
B20	ø20	●

* Blast type: Workpieces can be removed easily.

Mounting

Thread size (Symbol)	Pad diameter (Symbol)					
	B04	B06	B08	B10	B15	B20
A3 (M3 x 0.5 Male thread)	●	—	—	—	—	—
H5 (M5 x 0.8 Male thread)	—	●	●	●	●	●
B5 (M5 x 0.8 Female thread)	—	—	●	—	—	—

Pad material

Symbol	Material
N	NBR
S	Silicone rubber*1
U	Urethane rubber
F	FKM
GN	Conductive NBR
GS	Conductive silicone rubber

*1 Compliant with the FDA (USA Food and Drug Administration) regulation 21CFR§177.2600 for "Rubber articles intended for repeated use"

Pad form

Symbol	Form
MB	Bellows type

Replacement Part Nos.

Model	Pad unit part no.*1	Adapter part no.	Gasket part no. (Single unit)
ZP2-TB04MB□-A3	ZP2-B04MB□	ZP2A-M01P*2	M-3G2
ZP2-TB06MB□-H5	ZP2-B06MB□	ZP2A-M02P*2	10 pcs.*3: ZP-5G2
ZP2-TB08MB□-H5	ZP2-B08MB□	ZP2A-M05	100 pcs.*3: M-5G2
ZP2-TB10MB□-H5	ZP2-B10MB□	ZP2A-M05	—
ZP2-TB15MB□-H5	ZP2-B15MB□	ZP2A-M06	—
ZP2-TB20MB□-H5	ZP2-B20MB□	ZP2A-M06	—
ZP2-TB06MB□-B5	ZP2-B06MB□	ZP2A-M04	—
ZP2-TB08MB□-B5	ZP2-B08MB□	ZP2A-M04	—

*1 Pad unit's sales unit: 10 pcs.

*2 With gasket

*3 The gasket (single unit) sales unit is shown.

* □ in the table indicates the pad material

* The pad is shipped together but does not come assembled.

Dimensions: With Adapter

ZP2-TB04MB□□-A3

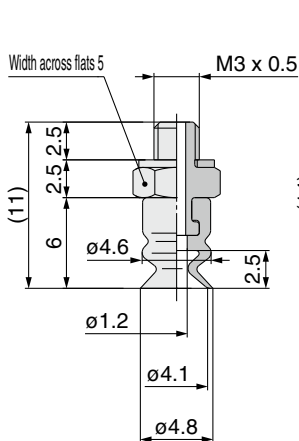

ZP2-TB06MB□-H5

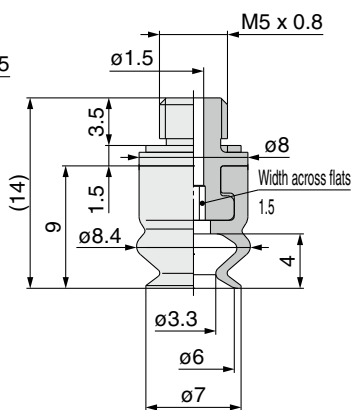

ZP2-TB08MB□-H5

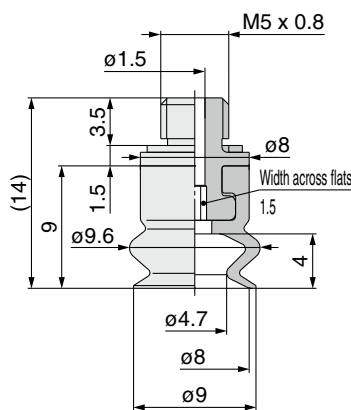

ZP2-TB10MB□-H5

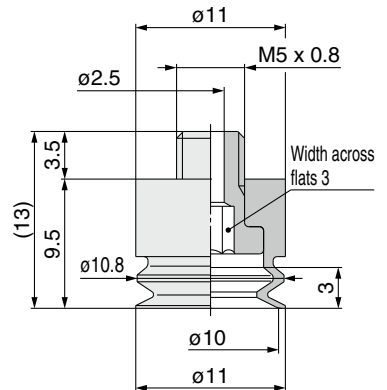

ZP2-TB15MB□-H5

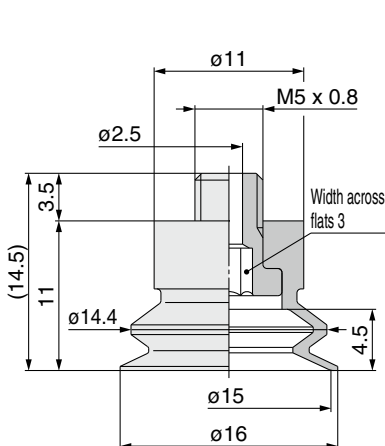

ZP2-TB20MB□-H5

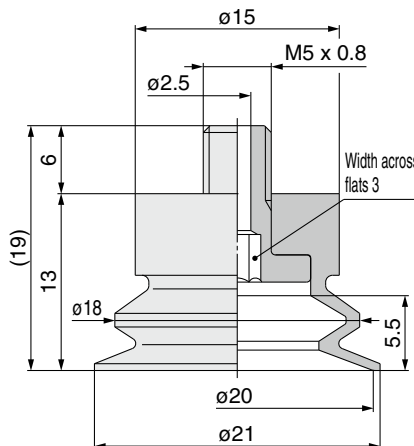

ZP2-TB06MB□-B5

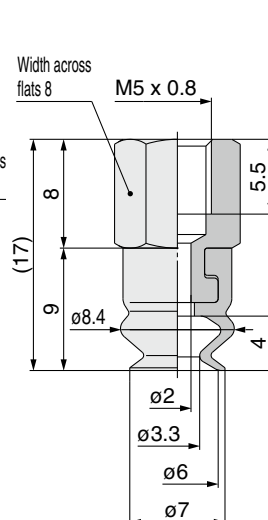

ZP2-TB08MB□-B5

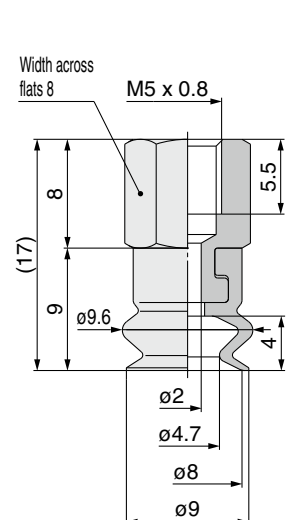

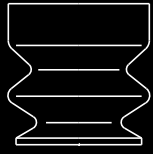

Bellows Pad

Pad diameter \rightarrow $\varnothing 2, \varnothing 4, \varnothing 5, \varnothing 6$

Symbol/Form

ZJ: Bellows type

Model Selection

- For use where there is no space for a buffer (spring type)
- For the adsorption of workpieces with inclined surfaces

How to Order



Pad unit **ZP2 - 02 ZJ N**

Pad diameter

Symbol	Pad diameter
02	$\varnothing 2$
04	$\varnothing 4$
05	$\varnothing 5$
06	$\varnothing 6$

Pad material

Symbol	Material
N	NBR
S	Silicone rubber*1
U	Urethane rubber
F	FKM
GN	Conductive NBR
GS	Conductive silicone rubber

*1 Compliant with the FDA (USA Food and Drug Administration) regulation 21CFR§177.2600 for "Rubber articles intended for repeated use"

Pad form

Symbol	Form
ZJ	Bellows type

* The mounting adapter is available as a special order.

Made to Order

ZP2V

XT661

MHM

Dimensions: Pad Unit

ZP2-02ZJ \square [0.1 g]

ZP2-04ZJ \square [0.1 g]

ZP2-05ZJ \square [0.2 g]

ZP2-06ZJ \square [0.3 g]

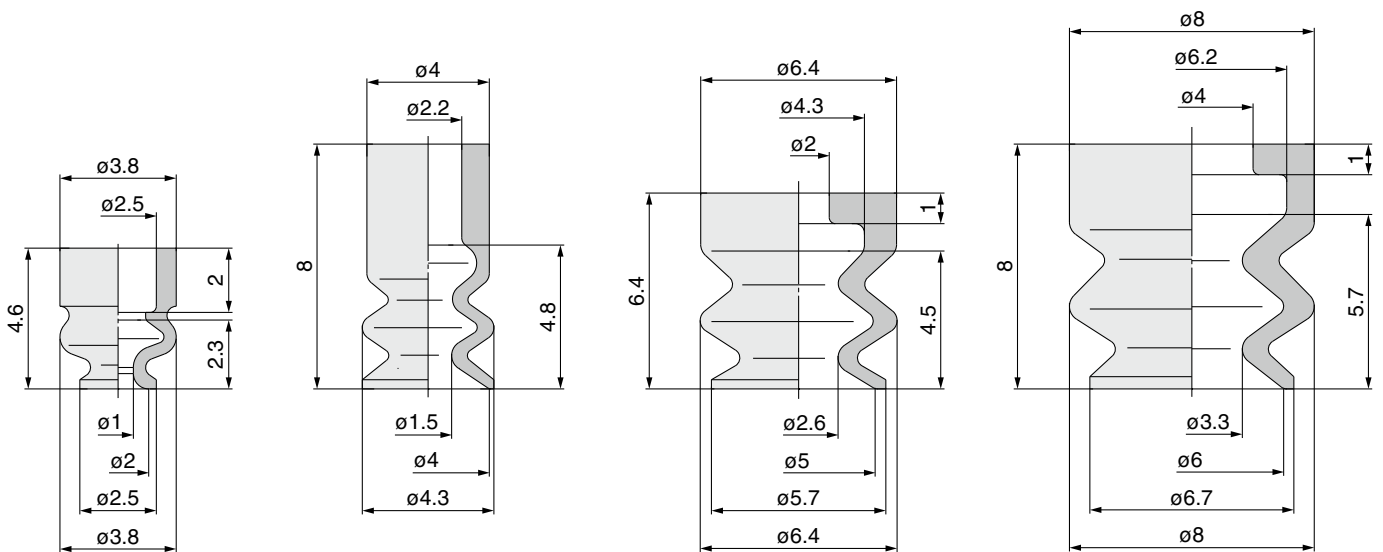

* Due to the small diameter of the ZP2-02ZJ, the pad portion may shrink before adsorption depending on the suction flow rate. For this reason, operate with the suction flow rate set to 2 [L/min (ANR)] or lower.

Precautions

High Rigidity Pad

Symbol/Form
H: High rigidity (Flat type with ribs)
HT: High rigidity (Thin flat type with ribs)

Pad diameter $\varnothing 32, \varnothing 150, \varnothing 250, \varnothing 300, \varnothing 340$

■ Reinforced pad to prevent deformation when transferring heavy or large workpieces

How to Order

Pad unit **ZP2-32 H N**



Pad diameter

Symbol	Pad diameter
32	$\varnothing 32$
150	$\varnothing 150$
250	$\varnothing 250$
300	$\varnothing 300$
340	$\varnothing 340$

Pad material

Symbol	Material
N	NBR
S	Silicone rubber*1
F	FKM
C	CR

*1 Silicone rubber is only applicable to the $\varnothing 32$ pad. Compliant with the FDA (USA Food and Drug Administration) regulation 21CFR§177.2600 for "Rubber articles intended for repeated use"

Pad form—Pad diameter

Pad form	Pad diameter (Symbol)				
	32	150	250	300	340
H (Flat type with ribs)	●	—	—	●	●
HT (Thin flat type with ribs)	—	●	●	—	—

* The mounting adapter is available as a special order.

Dimensions: Pad Unit

ZP2-32H□

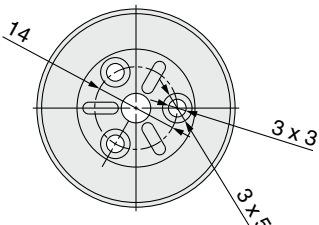
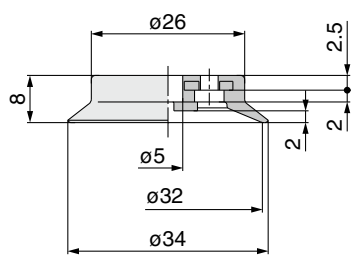

ZP2-300H□

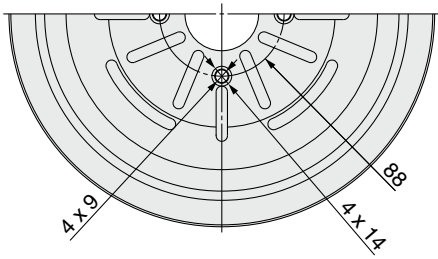
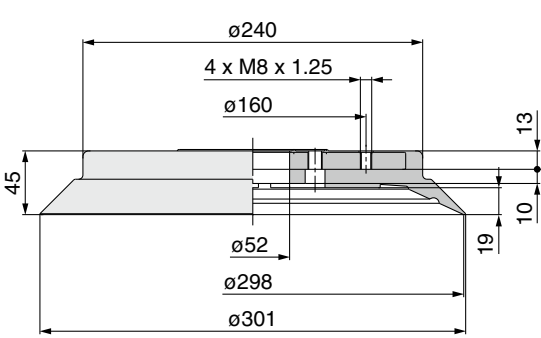

ZP2-340H□

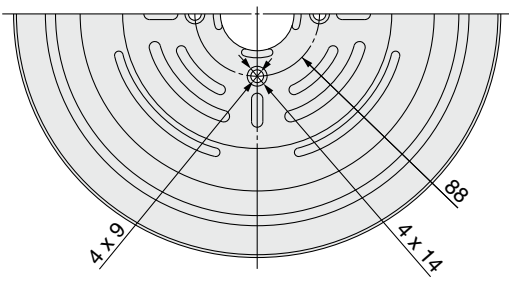
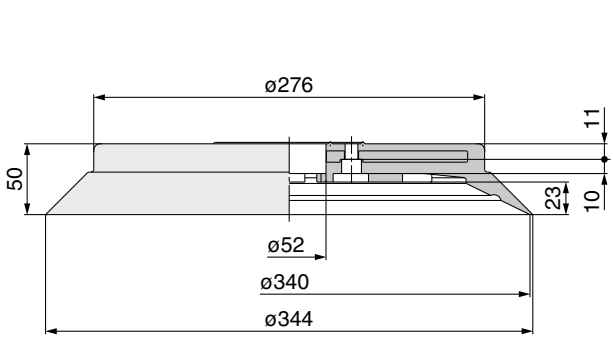

Dimensions

ZP2-150HT□

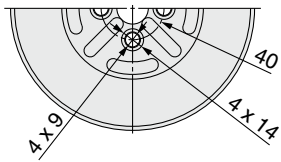
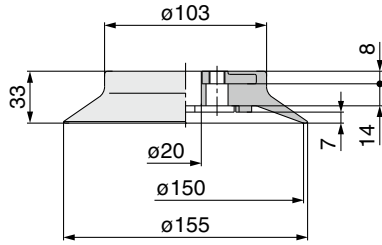

ZP2-250HT□

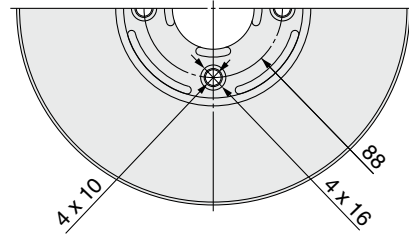
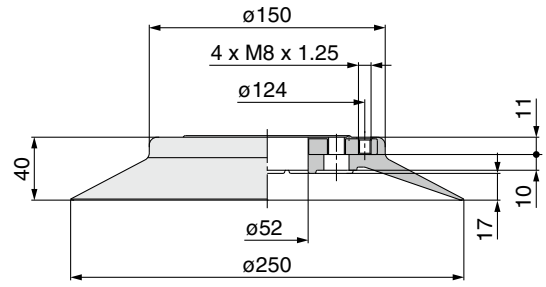

Made to Order

ZP2V

XT661

MHM

Precautions

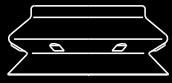

High Rigidity Pad

Pad diameter $\phi 32, \phi 150$

Symbol/Form

HB: High rigidity (Bellows type)

■ For heavy or large workpieces

How to Order



Pad unit **ZP2-32 HB N**

• Pad diameter

Symbol	Pad diameter
32	$\phi 32$
150	$\phi 150$

• Pad material

Symbol	Material
N	NBR
S	Silicone rubber*1
F	FKM
C	CR

*1 Silicone rubber is only applicable to the $\phi 32$ pad. Compliant with the FDA (USA Food and Drug Administration) regulation 21CFR§177.2600 for "Rubber articles intended for repeated use"

• Pad form

Symbol	Form
HB	High rigidity (Bellows type)

* The mounting adapter is available as a special order.

Dimensions: Pad Unit

ZP2-32HB □

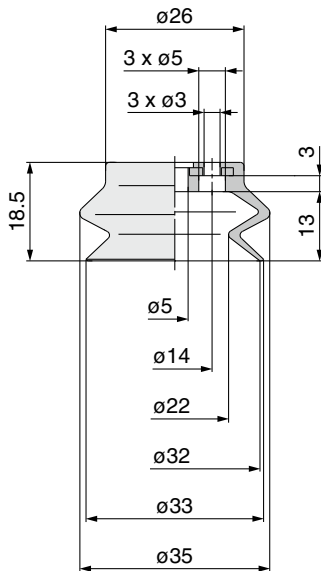

ZP2-150HB □

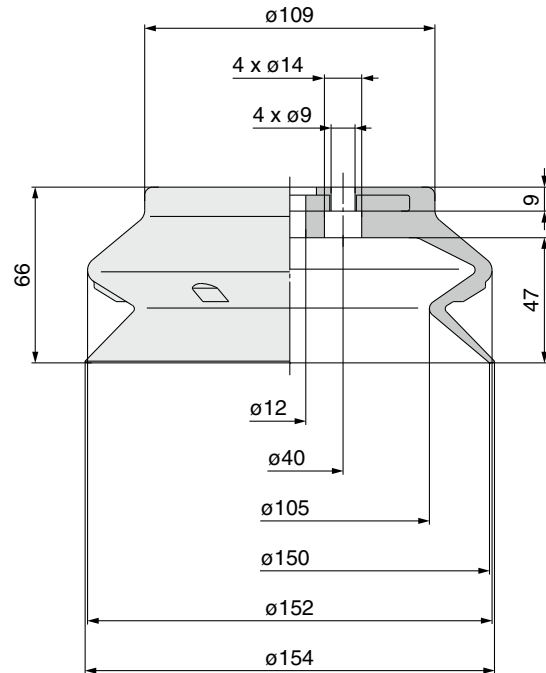



High Rigidity Pad

Symbol/Form

Pad size **30 x 50**

HW: High rigidity (Oval type)

Model Selection

■ For heavy or large workpieces

How to Order



Pad unit **ZP2 - 3050 HW N**

Pad size

Symbol	Pad size
3050	30 x 50

Pad material

Symbol	Material
N	NBR
S	Silicone rubber*1
F	FKM
C	CR

*1 Compliant with the FDA (USA Food and Drug Administration) regulation 21CFR§177.2600 for "Rubber articles intended for repeated use"

Pad form

Symbol	Form
HW	High rigidity (Oval type)

* For details on mounting brackets, refer to the special applications section of the pad on pages 255 to 263.

Dimensions: Pad Unit

ZP2-3050HW□

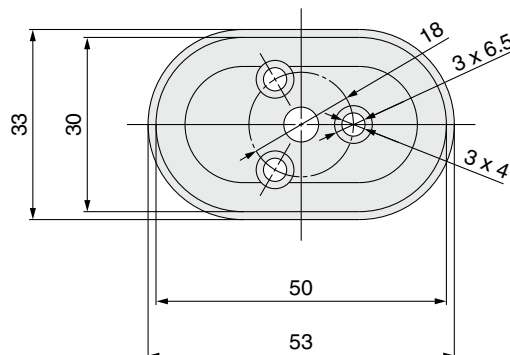
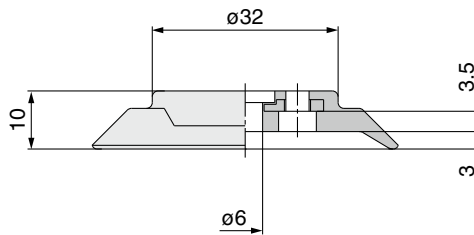
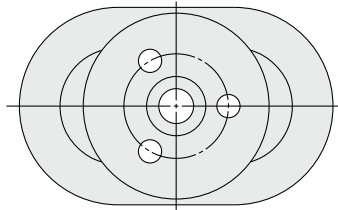

Made to Order

ZP2V

XT661

MHM

Precautions

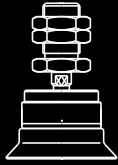

High Rigidity Ball Joint Pad

Symbol/Form

H: High rigidity
(Flat type with ribs)

Pad diameter $\varnothing 40, \varnothing 50, \varnothing 63, \varnothing 80, \varnothing 100, \varnothing 125$

■ For the adsorption of work-pieces with inclined surfaces

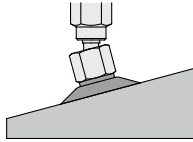

Replacement Part Nos.

Model	Pad unit part no.	Adapter assembly part no.
ZP2-TF40H□	ZP40H□	ZP2A-TF1 With three M3 bolts
ZP2-TF50H□	ZP50H□	ZP2A-TF1 With three M3 bolts
ZP2-TF63H□	ZP63H□	ZP2A-TF2 With four M4 bolts
ZP2-TF80H□	ZP80H□	ZP2A-TF2 With four M4 bolts
ZP2-TF100H□	ZP100H□	ZP2A-TF3 With four M5 bolts
ZP2-TF125H□	ZP125H□	ZP2A-TF3 With four M5 bolts

* □ in the table indicates the pad material

How to Order

With adapter **ZP2 – T F 40 H N**

Vacuum inlet direction

Symbol	Direction
T	Vertical

Specification (mechanism)

Symbol	Specification
F	Ball joint

Pad diameter

Symbol	Pad diameter
40	$\varnothing 40$
50	$\varnothing 50$
63	$\varnothing 63$
80	$\varnothing 80$
100	$\varnothing 100$
125	$\varnothing 125$

Pad form

Symbol	Form
H	High rigidity (Flat type with ribs)

Vacuum inlet direction **Vertical**

• Pad material (□)

Symbol	Material
N	NBR
S	Silicone rubber*1*2
U	Urethane rubber
F	FKM
E	EPDM

*1 Compliant with the FDA (USA Food and Drug Administration) regulation 21CFR§177.2600 for "Rubber articles intended for repeated use"

*2 Compliant with the standards for "Rubber apparatus (excluding baby drinking apparatus) and containers/packaging" (D3) (Partial revision: Ministry of Health, Labour, and Welfare Notification No. 595, 2012) in Section 3 "Apparatus and Containers/Packaging" of the Food Sanitation Act, Article 18 "Specifications and Standards for Food and Food Additives, etc." (Ministry of Health and Welfare Notification No. 370, 1959).

Dimensions: With Adapter

ZP2-TF⁴⁰/₅₀H□

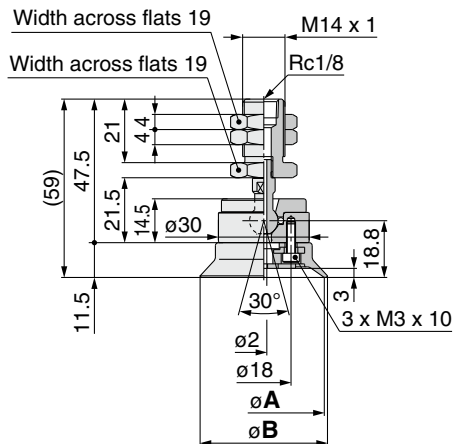

Dimensions

Model	A	B
ZP2-TF40H□	40	42.1
ZP2-TF50H□	50	52.1

ZP2-TF⁶³/₈₀H□

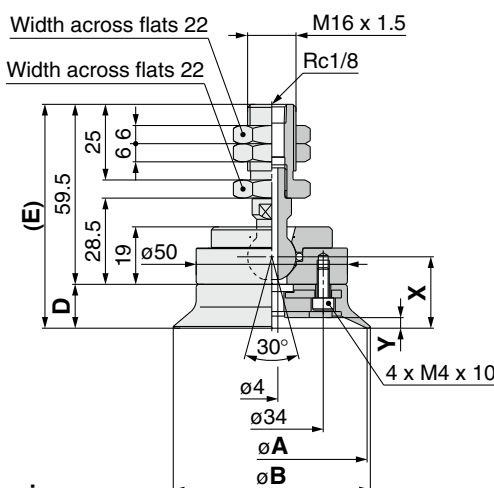

Dimensions

Model	A	B	D	E	X	Y
ZP2-TF63H□	63	65.2	14.5	74	23.6	3.5
ZP2-TF80H□	80	82.1	16.5	76	25.6	4.5

ZP2-TF¹⁰⁰/₁₂₅H□

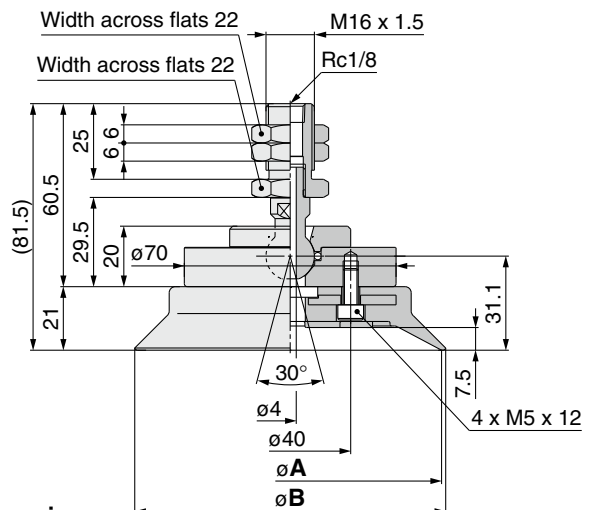

Dimensions

Model	A	B
ZP2-TF100H□	100	102.8
ZP2-TF125H□	125	127.7

How to Order



Vacuum inlet direction **Lateral**

With adapter **ZP2 - X F 40 H N**

Vacuum inlet direction

Symbol	Direction
X	Lateral

Specification (mechanism)

Symbol	Specification
F	Ball joint

Pad diameter

Symbol	Pad diameter
40	ø40
50	ø50
63	ø63
80	ø80
100	ø100
125	ø125

Pad form

Symbol	Form
H	High rigidity (Flat type with ribs)

Pad material (□)

Symbol	Material
N	NBR
S	Silicone rubber*1*2
U	Urethane rubber
F	FKM
E	EPDM

*1 Compliant with the FDA (USA Food and Drug Administration) regulation 21CFR§177.2600 for "Rubber articles intended for repeated use"

*2 Compliant with the standards for "Rubber apparatus (excluding baby drinking apparatus) and containers/packaging" (D3) (Partial revision: Ministry of Health, Labour, and Welfare Notification No. 595, 2012) in Section 3 "Apparatus and Containers/Packaging" of the Food Sanitation Act, Article 18 "Specifications and Standards for Food and Food Additives, etc." (Ministry of Health and Welfare Notification No. 370, 1959).

Replacement Part Nos.

Model	Pad unit part no.	Adapter assembly part no.	
ZP2-XF40H □	ZP40H□	ZP2A-XF1	With three M3 bolts
ZP2-XF50H □	ZP50H□		
ZP2-XF63H □	ZP63H□	ZP2A-XF2	With four M4 bolts
ZP2-XF80H □	ZP80H□		
ZP2-XF100H □	ZP100H□	ZP2A-XF3	With four M5 bolts
ZP2-XF125H □	ZP125H□		

* □ in the table indicates the pad material

Dimensions: With Adapter

ZP2-XF⁴⁰/₅₀H□

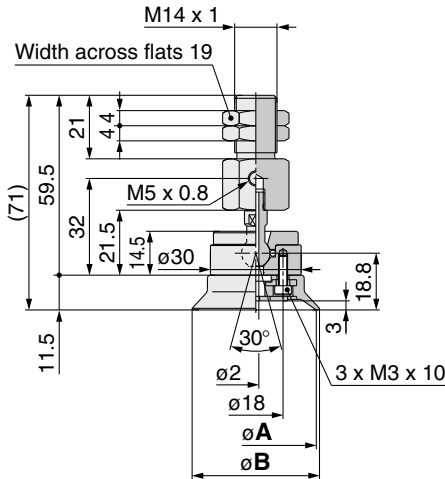

Dimensions

Model	A	B
ZP2-XF40H □	40	42.1
ZP2-XF50H □	50	52.1

ZP2-XF⁶³/₈₀H□

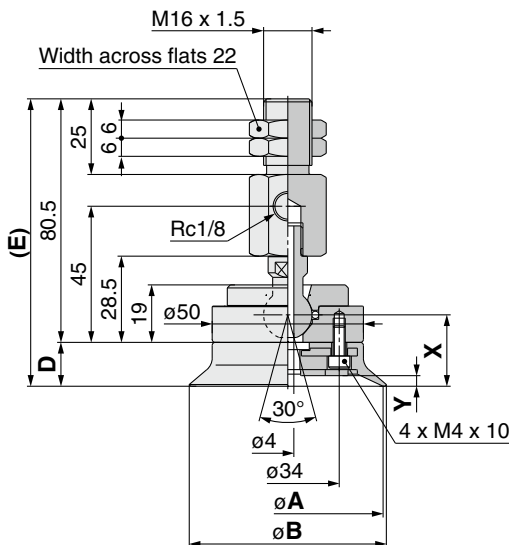

Dimensions

Model	A	B	D	E	X	Y
ZP2-XF63H □	63	65.2	14.5	95	23.6	3.5
ZP2-XF80H □	80	82.1	16.5	97	25.6	4.5

ZP2-XF¹⁰⁰/₁₂₅H□

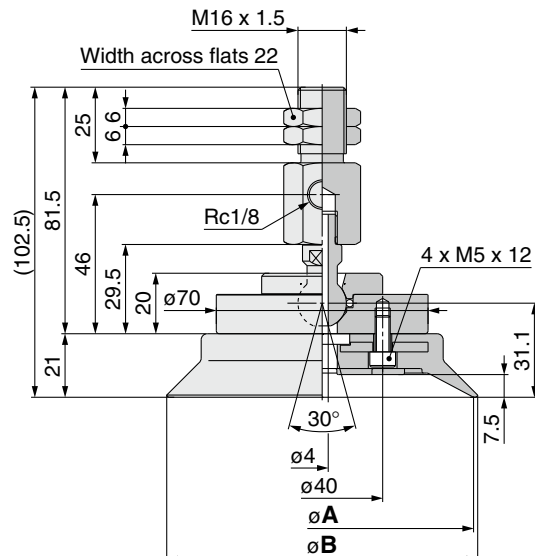

Dimensions

Model	A	B
ZP2-XF100H □	100	102.8
ZP2-XF125H □	125	127.7

High Rigidity Ball Joint Pad **ZP2 Series**

How to Order

With buffer **ZP2 – T F 40 H N JB 25**

Vacuum inlet direction

Symbol	Direction
T	Vertical

Specification (mechanism)

Symbol	Specification
F	Ball joint

Pad diameter

Symbol	Pad diameter
40	ø40
50	ø50
63	ø63
80	ø80
100	ø100
125	ø125

Pad form

Symbol	Form
H	High rigidity (Flat type with ribs)

Buffer stroke (■)

Stroke	Pad diameter			
	ø40 ø50	ø63 ø80	ø100 ø125	
25	●	●	●	
50	●	●	●	
75	●	●	●	
100	—	●	●	

Buffer specification

Symbol	Specification
JB	Rotating With bushing Material: Brass
JF	Rotating With bushing Material: Structural steel

Pad material (□)

Symbol	Material
N	NBR
S	Silicone rubber*1*2
U	Urethane rubber
F	FKM
E	EPDM



Vacuum inlet direction **Vertical**

- *1 Compliant with the FDA (USA Food and Drug Administration) regulation 21CFR§177.2600 for "Rubber articles intended for repeated use"
- *2 Compliant with the standards for "Rubber apparatus (excluding baby drinking apparatus) and containers/packaging" (D3) (Partial revision: Ministry of Health, Labour, and Welfare Notification No. 595, 2012) in Section 3 "Apparatus and Containers/Packaging" of the Food Sanitation Act, Article 18 "Specifications and Standards for Food and Food Additives, etc." (Ministry of Health and Welfare Notification No. 370, 1959).

Replacement Part Nos.

Model	Pad unit part no.	Buffer assembly part no.	
ZP2-TF40H□(JB/JF)25	ZP40H□	ZP2B-TF1(JB/JF)25	With three M3 bolts
ZP2-TF40H□(JB/JF)50		ZP2B-TF1(JB/JF)50	
ZP2-TF40H□(JB/JF)75		ZP2B-TF1(JB/JF)75	
ZP2-TF50H□(JB/JF)25	ZP50H□	ZP2B-TF1(JB/JF)25	
ZP2-TF50H□(JB/JF)50		ZP2B-TF1(JB/JF)50	
ZP2-TF50H□(JB/JF)75		ZP2B-TF1(JB/JF)75	
ZP2-TF63H□(JB/JF)25	ZP63H□	ZP2B-TF2(JB/JF)25	With four M4 bolts
ZP2-TF63H□(JB/JF)50		ZP2B-TF2(JB/JF)50	
ZP2-TF63H□(JB/JF)75		ZP2B-TF2(JB/JF)75	
ZP2-TF63H□(JB/JF)100	ZP80H□	ZP2B-TF2(JB/JF)100	
ZP2-TF80H□(JB/JF)25		ZP2B-TF2(JB/JF)25	
ZP2-TF80H□(JB/JF)50		ZP2B-TF2(JB/JF)50	
ZP2-TF80H□(JB/JF)75	ZP100H□	ZP2B-TF2(JB/JF)75	With four M5 bolts
ZP2-TF80H□(JB/JF)100		ZP2B-TF2(JB/JF)100	
ZP2-TF100H□(JB/JF)25		ZP2B-TF3(JB/JF)25	
ZP2-TF100H□(JB/JF)50	ZP125H□	ZP2B-TF3(JB/JF)50	
ZP2-TF100H□(JB/JF)75		ZP2B-TF3(JB/JF)75	
ZP2-TF100H□(JB/JF)100		ZP2B-TF3(JB/JF)100	
ZP2-TF125H□(JB/JF)25	ZP125H□	ZP2B-TF3(JB/JF)25	
ZP2-TF125H□(JB/JF)50		ZP2B-TF3(JB/JF)50	
ZP2-TF125H□(JB/JF)75		ZP2B-TF3(JB/JF)75	
ZP2-TF125H□(JB/JF)100		ZP2B-TF3(JB/JF)100	

* □ in the table indicates the pad material

Buffer Specifications

Pad diameter		ø40, ø50	ø63, ø80, ø100, ø125
Stroke [mm]		25, 50, 75	25, 50, 75, 100
Spring reactive force [N]	At 0 stroke	6.9	10
	At full stroke	11.8	15
Buffer specifications	JB	Rotating With bushing Buffer body material: Brass Nut tightening torque: 28 to 32 N·m Nut tightening torque: 45 to 50 N·m	
	JF	Rotating With bushing Buffer body material: Structural steel Nut tightening torque: 48 to 52 N·m Nut tightening torque: 75 to 80 N·m	

Dimensions: With Buffer

ZP2-TF⁴⁰H □ JB ■ 50H □ JF ■

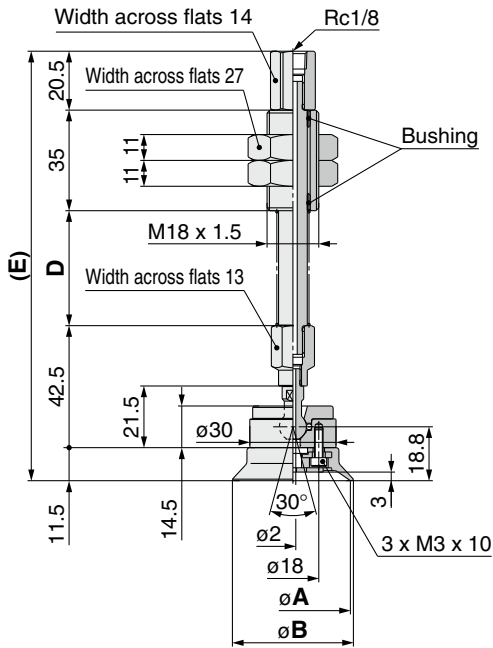

Dimensions

Model	A	B	D	E
ZP2-TF40H □ (JB/JF)25	40	42.1	40	149.5
ZP2-TF40H □ (JB/JF)50			75	184.5
ZP2-TF40H □ (JB/JF)75			111	220.5
ZP2-TF50H □ (JB/JF)25	50	52.1	40	149.5
ZP2-TF50H □ (JB/JF)50			75	184.5
ZP2-TF50H □ (JB/JF)75			111	220.5

ZP2-TF⁶³H □ JB ■ 80H □ JF ■

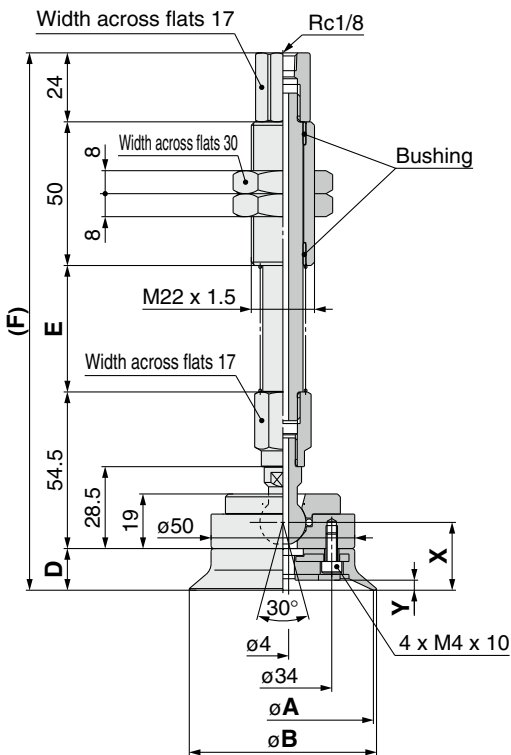

Dimensions

Model	A	B	D	E	F	X	Y
ZP2-TF63H □ (JB/JF)25	63	65.2	14.5	44	187	23.6	3.5
ZP2-TF63H □ (JB/JF)50				80	223		
ZP2-TF63H □ (JB/JF)75				120	263		
ZP2-TF63H □ (JB/JF)100	80	82.1	16.5	44	189	25.6	4.5
ZP2-TF80H □ (JB/JF)25				80	225		
ZP2-TF80H □ (JB/JF)75				120	265		
ZP2-TF80H □ (JB/JF)100				155	300		

ZP2-TF¹⁰⁰H □ JB ■ 125H □ JF ■

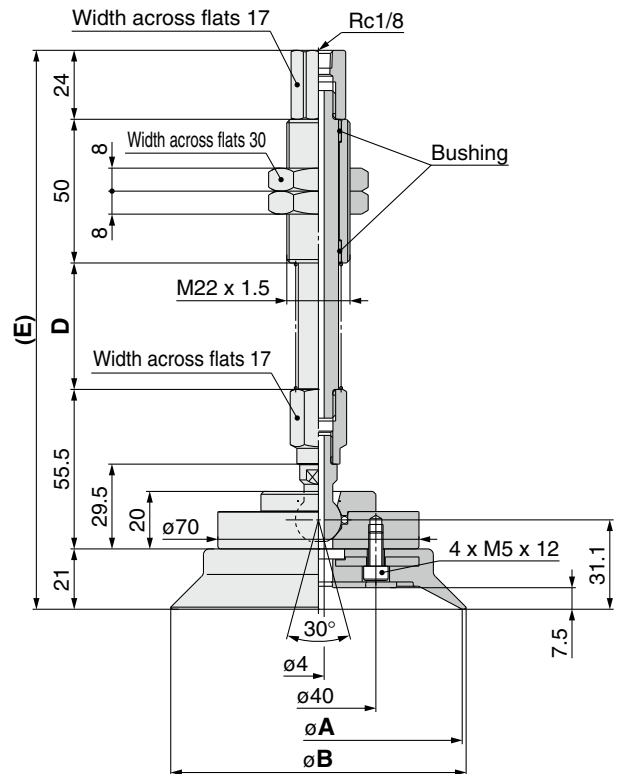

Dimensions

Model	A	B	D	E
ZP2-TF100H □ (JB/JF)25	100	102.8	44	194.5
ZP2-TF100H □ (JB/JF)50			80	230.5
ZP2-TF100H □ (JB/JF)75			120	270.5
ZP2-TF100H □ (JB/JF)100	125	127.7	155	305.5
ZP2-TF125H □ (JB/JF)25			44	194.5
ZP2-TF125H □ (JB/JF)50			80	230.5
ZP2-TF125H □ (JB/JF)75			120	270.5
ZP2-TF125H □ (JB/JF)100			155	305.5

High Rigidity Ball Joint Pad **ZP2 Series**

How to Order

With buffer **ZP2 – X F 40 H N JB 25**

Vacuum inlet direction

Symbol	Direction
X	Lateral

Specification (mechanism)

Symbol	Specification
F	Ball joint

Pad diameter

Symbol	Pad diameter
40	ø40
50	ø50
63	ø63
80	ø80
100	ø100
125	ø125

Pad form

Symbol	Form
H	High rigidity (Flat type with ribs)

Buffer stroke (■)

Stroke	Pad diameter			
	ø40 ø50	ø63 ø80	ø100	ø125
25	●	●	●	●
50	●	●	●	●
75	●	●	●	●
100	—	●	●	●

Buffer specification

Symbol	Specification
JB	Rotating With bushing Material: Brass
JF	Rotating With bushing Material: Structural steel

Pad material (□)

Symbol	Material
N	NBR
S	Silicone rubber*1*2
U	Urethane rubber
F	FKM
E	EPDM

*1 Compliant with the FDA (USA Food and Drug Administration) regulation 21CFR§177.2600 for "Rubber articles intended for repeated use"

*2 Compliant with the standards for "Rubber apparatus (excluding baby drinking apparatus) and containers/packaging" (D3) (Partial revision: Ministry of Health, Labour, and Welfare Notification No. 595, 2012) in Section 3 "Apparatus and Containers/Packaging" of the Food Sanitation Act, Article 18 "Specifications and Standards for Food and Food Additives, etc." (Ministry of Health and Welfare Notification No. 370, 1959).



Vacuum inlet direction **Lateral**

Replacement Part Nos.

Model	Pad unit part no.	Buffer assembly part no.	
ZP2-XF40H□(JB/JF)25	ZP40H□	ZP2B-XF1(JB/JF)25	With three M3 bolts
ZP2-XF40H□(JB/JF)50		ZP2B-XF1(JB/JF)50	
ZP2-XF40H□(JB/JF)75		ZP2B-XF1(JB/JF)75	
ZP2-XF50H□(JB/JF)25	ZP50H□	ZP2B-XF1(JB/JF)25	With three M3 bolts
ZP2-XF50H□(JB/JF)50		ZP2B-XF1(JB/JF)50	
ZP2-XF50H□(JB/JF)75		ZP2B-XF1(JB/JF)75	
ZP2-XF63H□(JB/JF)25	ZP63H□	ZP2B-XF2(JB/JF)25	With four M4 bolts
ZP2-XF63H□(JB/JF)50		ZP2B-XF2(JB/JF)50	
ZP2-XF63H□(JB/JF)75		ZP2B-XF2(JB/JF)75	
ZP2-XF63H□(JB/JF)100	ZP80H□	ZP2B-XF2(JB/JF)100	With four M4 bolts
ZP2-XF80H□(JB/JF)25		ZP2B-XF2(JB/JF)25	
ZP2-XF80H□(JB/JF)50		ZP2B-XF2(JB/JF)50	
ZP2-XF80H□(JB/JF)75	ZP100H□	ZP2B-XF2(JB/JF)75	With four M5 bolts
ZP2-XF80H□(JB/JF)100		ZP2B-XF2(JB/JF)100	
ZP2-XF100H□(JB/JF)25		ZP2B-XF3(JB/JF)25	
ZP2-XF100H□(JB/JF)50	ZP125H□	ZP2B-XF3(JB/JF)50	With four M5 bolts
ZP2-XF100H□(JB/JF)75		ZP2B-XF3(JB/JF)75	
ZP2-XF100H□(JB/JF)100		ZP2B-XF3(JB/JF)100	
ZP2-XF125H□(JB/JF)25	ZP125H□	ZP2B-XF3(JB/JF)25	With four M5 bolts
ZP2-XF125H□(JB/JF)50		ZP2B-XF3(JB/JF)50	
ZP2-XF125H□(JB/JF)75		ZP2B-XF3(JB/JF)75	
ZP2-XF125H□(JB/JF)100		ZP2B-XF3(JB/JF)100	

* □ in the table indicates the pad material

Buffer Specifications

Pad diameter		ø40, ø50	ø63, ø80, ø100, ø125
Stroke [mm]		25, 50, 75	25, 50, 75, 100
Spring reactive force [N]	At 0 stroke	6.9	10
	At full stroke	11.8	15
Buffer specifications	JB	Rotating With bushing Buffer body material: Brass Nut tightening torque: 28 to 32 N·m Nut tightening torque: 45 to 50 N·m	
	JF	Rotating With bushing Buffer body material: Structural steel Nut tightening torque: 48 to 52 N·m Nut tightening torque: 75 to 80 N·m	

Dimensions: With Buffer

ZP2-XF⁴⁰₅₀H □ JB JF ■

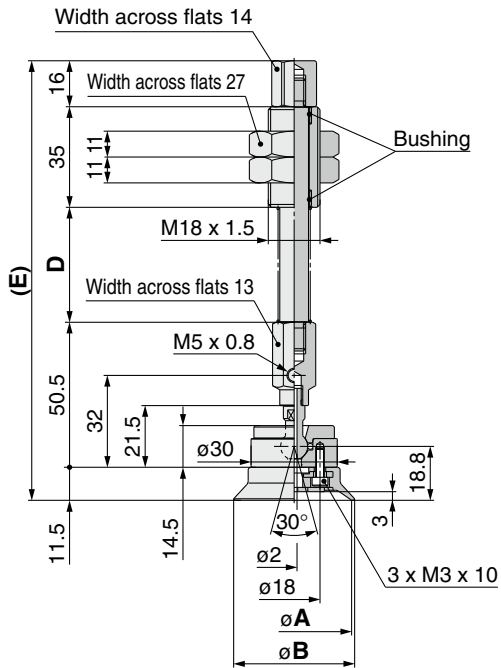

Dimensions

Model	A	B	D	E
ZP2-XF40H □ (JB/JF)25	40	42.1	40	153
ZP2-XF40H □ (JB/JF)50			75	188
ZP2-XF40H □ (JB/JF)75			111	224
ZP2-XF50H □ (JB/JF)25	50	52.1	40	153
ZP2-XF50H □ (JB/JF)50			75	188
ZP2-XF50H □ (JB/JF)75			111	224

ZP2-XF⁶³₈₀H □ JB JF ■

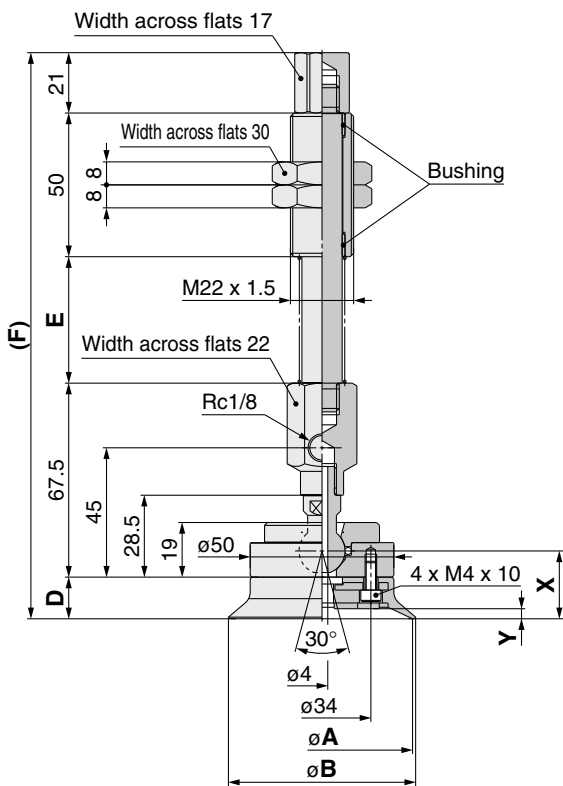

Dimensions

Model	A	B	D	E	F	X	Y
ZP2-XF63H □ (JB/JF)25	63	65.2	14.5	44	197	23.6	3.5
ZP2-XF63H □ (JB/JF)50				80	233		
ZP2-XF63H □ (JB/JF)75				120	273		
ZP2-XF63H □ (JB/JF)100	155	308					
ZP2-XF80H □ (JB/JF)25	80	82.1	16.5	44	199	25.6	4.5
ZP2-XF80H □ (JB/JF)50				80	235		
ZP2-XF80H □ (JB/JF)75				120	275		
ZP2-XF80H □ (JB/JF)100				155	310		

ZP2-XF¹⁰⁰₁₂₅H □ JB JF ■

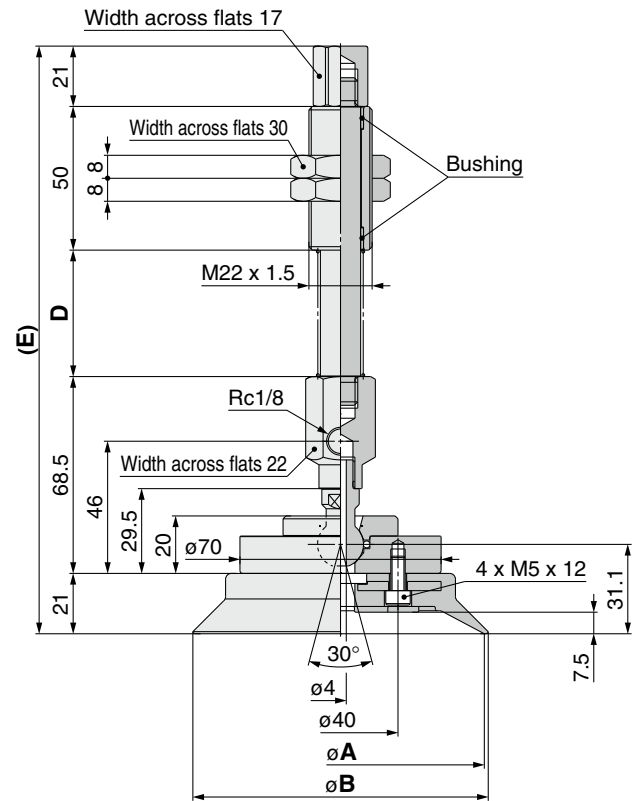

Dimensions

Model	A	B	D	E
ZP2-XF100H □ (JB/JF)25	100	102.8	44	204.5
ZP2-XF100H □ (JB/JF)50			80	240.5
ZP2-XF100H □ (JB/JF)75			120	280.5
ZP2-XF100H □ (JB/JF)100			155	315.5
ZP2-XF125H □ (JB/JF)25	125	127.7	44	204.5
ZP2-XF125H □ (JB/JF)50			80	240.5
ZP2-XF125H □ (JB/JF)75			120	280.5
ZP2-XF125H □ (JB/JF)100			155	315.5



High Rigidity Ball Joint Pad

Symbol/Form

HB: High rigidity (Bellows type)

Pad diameter $\varnothing 40, \varnothing 50, \varnothing 63, \varnothing 80, \varnothing 100, \varnothing 125$

■ For the adsorption of workpieces with inclined or curved surfaces

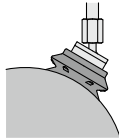

Replacement Part Nos.

Model	Pad unit part no.	Adapter assembly part no.
ZP2-TF40HB□	ZP40HB□	ZP2A-TF1 With three M3 bolts
ZP2-TF50HB□	ZP50HB□	
ZP2-TF63HB□	ZP63HB□	ZP2A-TF2 With four M4 bolts
ZP2-TF80HB□	ZP80HB□	
ZP2-TF100HB□	ZP100HB□	ZP2A-TF3 With four M5 bolts
ZP2-TF125HB□	ZP125HB□	

* □ in the table indicates the pad material

How to Order

With adapter **ZP2-TF40HB N**

Vacuum inlet direction

Symbol	Direction
T	Vertical

Specification (mechanism)

Symbol	Specification
F	Ball joint

Pad diameter

Symbol	Pad diameter
40	$\varnothing 40$
50	$\varnothing 50$
63	$\varnothing 63$
80	$\varnothing 80$
100	$\varnothing 100$
125	$\varnothing 125$

Pad form

Symbol	Form
HB	High rigidity (Bellows type)

Pad material (□)

Symbol	Material
N	NBR
S	Silicone rubber*1*2
U	Urethane rubber
F	FKM
E	EPDM

*1 Compliant with the FDA (USA Food and Drug Administration) regulation 21CFR§177.2600 for "Rubber articles intended for repeated use"
 *2 Compliant with the standards for "Rubber apparatus (excluding baby drinking apparatus) and containers/packaging" (D3) (Partial revision: Ministry of Health, Labour, and Welfare Notification No. 595, 2012) in Section 3 "Apparatus and Containers/Packaging" of the Food Sanitation Act, Article 18 "Specifications and Standards for Food and Food Additives, etc." (Ministry of Health and Welfare Notification No. 370, 1959).



Vacuum inlet direction
Vertical

Dimensions: With Adapter

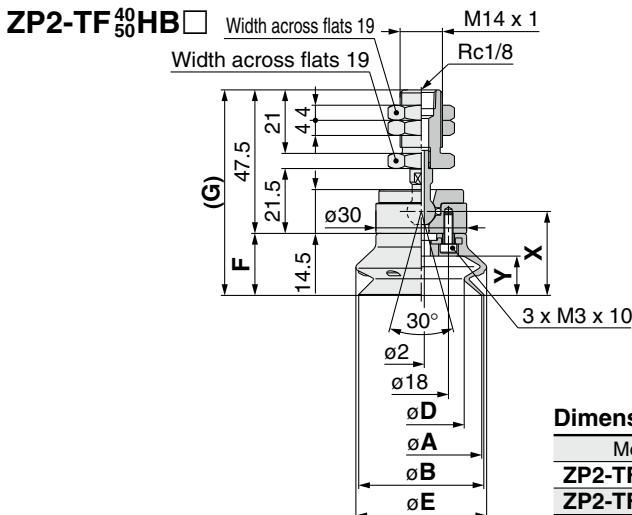

Dimensions

Model	A	B	D	E	F	G	X	Y
ZP2-TF40HB□	40	41.4	28.3	42.3	20.5	68	27.8	13
ZP2-TF50HB□	50	52	36.2	52.7	24	71.5	31.3	16.5

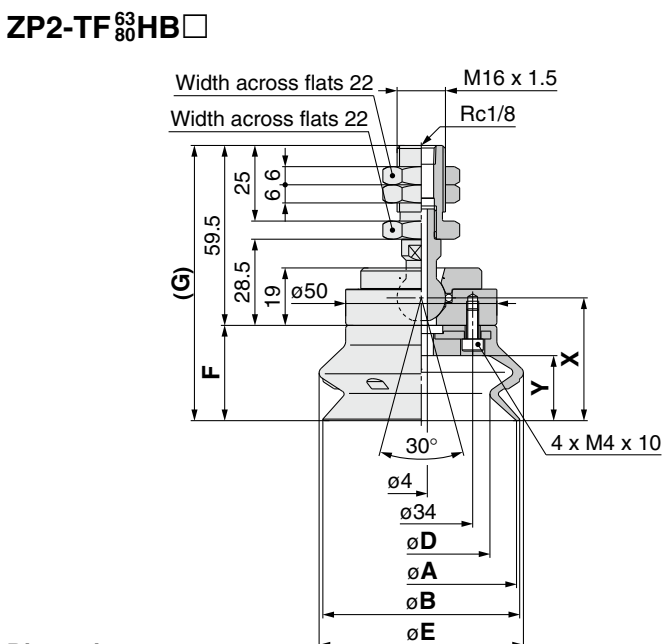

Dimensions

Model	A	B	D	E	F	G	X	Y
ZP2-TF63HB□	63	65.1	46	66.4	31.5	91	40.6	21.5
ZP2-TF80HB□	80	82.8	60.1	83.8	37	96.5	46.1	27.5

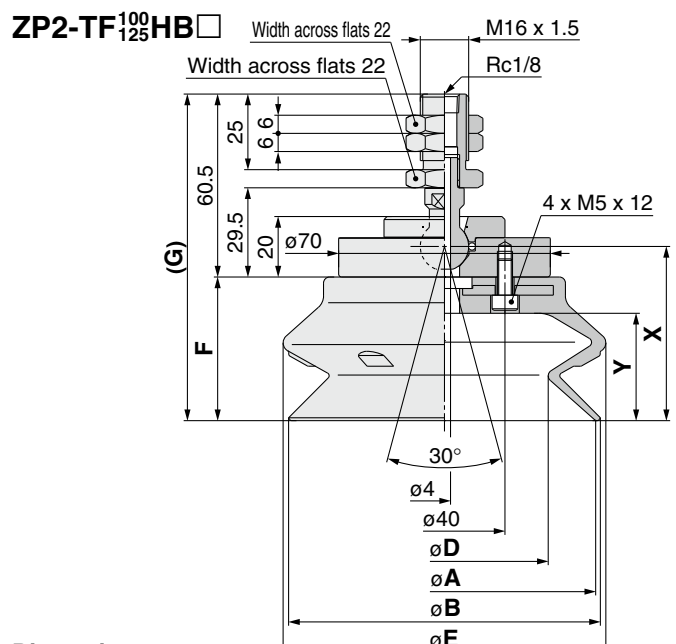

Dimensions

Model	A	B	D	E	F	G	X	Y
ZP2-TF100HB□	100	103	72.5	103.9	47.5	108	57.6	35.5
ZP2-TF125HB□	125	128.5	92.2	131.6	56	116.5	66.1	44

Model Selection

How to Order



With adapter **ZP2-X F 40 HB N**

Vacuum inlet direction

Symbol	Direction
X	Lateral

Specification (mechanism)

Symbol	Specification
F	Ball joint

Pad diameter

Symbol	Pad diameter
40	ø40
50	ø50
63	ø63
80	ø80
100	ø100
125	ø125

Pad form

Symbol	Form
HB	High rigidity (Bellows type)

Pad material (□)

Symbol	Material
N	NBR
S	Silicone rubber*1*2
U	Urethane rubber
F	FKM
E	EPDM

*1 Compliant with the FDA (USA Food and Drug Administration) regulation 21CFR§177.2600 for "Rubber articles intended for repeated use"
 *2 Compliant with the standards for "Rubber apparatus (excluding baby drinking apparatus) and containers/packaging" (D3) (Partial revision: Ministry of Health, Labour, and Welfare Notification No. 595, 2012) in Section 3 "Apparatus and Containers/Packaging" of the Food Sanitation Act, Article 18 "Specifications and Standards for Food and Food Additives, etc." (Ministry of Health and Welfare Notification No. 370, 1959).

Vacuum inlet direction **Lateral**

Replacement Part Nos.

Model	Pad unit part no.	Adapter assembly part no.	
ZP2-XF40HB□	ZP40HB□	ZP2A-XF1	With three M3 bolts
ZP2-XF50HB□	ZP50HB□	ZP2A-XF2	With four M4 bolts
ZP2-XF63HB□	ZP63HB□		
ZP2-XF80HB□	ZP80HB□	ZP2A-XF3	With four M5 bolts
ZP2-XF100HB□	ZP100HB□		
ZP2-XF125HB□	ZP125HB□		

* □ in the table indicates the pad material

Made to Order

ZP2V

XT661

MHM

Dimensions: With Adapter

ZP2-XF^{40/50}HB□ M14 x 1

Dimensions

Model	A	B	D	E	F	G	X	Y
ZP2-XF40HB□	40	41.4	28.3	42.3	20.5	80	27.8	13
ZP2-XF50HB□	50	52	36.2	52.7	24	83.5	31.3	16.5

ZP2-XF^{63/80}HB□ M16 x 1.5

Dimensions

Model	A	B	D	E	F	G	X	Y
ZP2-XF63HB□	63	65.1	46	66.4	31.5	112	40.6	21.5
ZP2-XF80HB□	80	82.8	60.1	83.8	37	117.5	46.1	27.5

ZP2-XF^{100/125}HB□ M16 x 1.5

Dimensions

Model	A	B	D	E	F	G	X	Y
ZP2-XF100HB□	100	103	72.5	103.9	47.5	129	57.6	35.5
ZP2-XF125HB□	125	128.5	92.2	131.6	56	137.5	66.1	44

Precautions

High Rigidity Ball Joint Pad **ZP2 Series**

How to Order

With buffer **ZP2 – T F 40 HB □ N JB 25**

• Vacuum inlet direction

Symbol	Direction
T	Vertical

• Specification (mechanism)

Symbol	Specification
F	Ball joint

• Pad diameter

Symbol	Pad diameter
40	ø40
50	ø50
63	ø63
80	ø80
100	ø100
125	ø125

• Pad form

Symbol	Form
HB	High rigidity (Bellows type)

• Buffer stroke (■)

Stroke	Pad diameter			
	ø40 ø50	ø63 ø80	ø100 ø125	
25	●	●	●	
50	●	●	●	
75	●	●	●	
100	—	●	●	

• Buffer specification

Symbol	Specification
JB	Rotating With bushing Material: Brass
JF	Rotating With bushing Material: Structural steel

• Pad material (□)

Symbol	Material
N	NBR
S	Silicone rubber*1*2
U	Urethane rubber
F	FKM
E	EPDM

*1 Compliant with the FDA (USA Food and Drug Administration) regulation 21CFR§177.2600 for "Rubber articles intended for repeated use"

*2 Compliant with the standards for "Rubber apparatus (excluding baby drinking apparatus) and containers/packaging" (D3) (Partial revision: Ministry of Health, Labour, and Welfare Notification No. 595, 2012) in Section 3 "Apparatus and Containers/Packaging" of the Food Sanitation Act, Article 18 "Specifications and Standards for Food and Food Additives, etc." (Ministry of Health and Welfare Notification No. 370, 1959).



Vacuum inlet direction **Vertical**

Replacement Part Nos.

Model	Pad unit part no.	Buffer assembly part no.	
ZP2-TF40HB□(JB/JF)25	ZP40HB□	ZP2B-TF1(JB/JF)25	With three M3 bolts
ZP2-TF40HB□(JB/JF)50		ZP2B-TF1(JB/JF)50	
ZP2-TF40HB□(JB/JF)75		ZP2B-TF1(JB/JF)75	
ZP2-TF50HB□(JB/JF)25	ZP50HB□	ZP2B-TF1(JB/JF)25	With four M4 bolts
ZP2-TF50HB□(JB/JF)50		ZP2B-TF1(JB/JF)50	
ZP2-TF50HB□(JB/JF)75		ZP2B-TF1(JB/JF)75	
ZP2-TF63HB□(JB/JF)25	ZP63HB□	ZP2B-TF2(JB/JF)25	With four M4 bolts
ZP2-TF63HB□(JB/JF)50		ZP2B-TF2(JB/JF)50	
ZP2-TF63HB□(JB/JF)75		ZP2B-TF2(JB/JF)75	
ZP2-TF63HB□(JB/JF)100	ZP80HB□	ZP2B-TF2(JB/JF)100	With four M4 bolts
ZP2-TF80HB□(JB/JF)25		ZP2B-TF2(JB/JF)25	
ZP2-TF80HB□(JB/JF)50		ZP2B-TF2(JB/JF)50	
ZP2-TF80HB□(JB/JF)75	ZP100HB□	ZP2B-TF2(JB/JF)75	With four M5 bolts
ZP2-TF80HB□(JB/JF)100		ZP2B-TF2(JB/JF)100	
ZP2-TF100HB□(JB/JF)25		ZP2B-TF3(JB/JF)25	
ZP2-TF100HB□(JB/JF)50	ZP125HB□	ZP2B-TF3(JB/JF)50	With four M5 bolts
ZP2-TF100HB□(JB/JF)75		ZP2B-TF3(JB/JF)75	
ZP2-TF100HB□(JB/JF)100		ZP2B-TF3(JB/JF)100	
ZP2-TF125HB□(JB/JF)25	ZP125HB□	ZP2B-TF3(JB/JF)25	With four M5 bolts
ZP2-TF125HB□(JB/JF)50		ZP2B-TF3(JB/JF)50	
ZP2-TF125HB□(JB/JF)75		ZP2B-TF3(JB/JF)75	
ZP2-TF125HB□(JB/JF)100		ZP2B-TF3(JB/JF)100	

* □ in the table indicates the pad material

Buffer Specifications

Pad diameter		ø40, ø50	ø63, ø80, ø100, ø125
Stroke [mm]		25, 50, 75	25, 50, 75, 100
Spring reactive force [N]	At 0 stroke	6.9	10
	At full stroke	11.8	15
Buffer specifications	JB	Rotating With bushing Buffer body material: Brass Nut tightening torque: 28 to 32 N·m Nut tightening torque: 45 to 50 N·m	
	JF	Rotating With bushing Buffer body material: Structural steel Nut tightening torque: 48 to 52 N·m Nut tightening torque: 75 to 80 N·m	

Dimensions: With Buffer

ZP2-TF⁴⁰₅₀HB□^{JB}_{JF}■

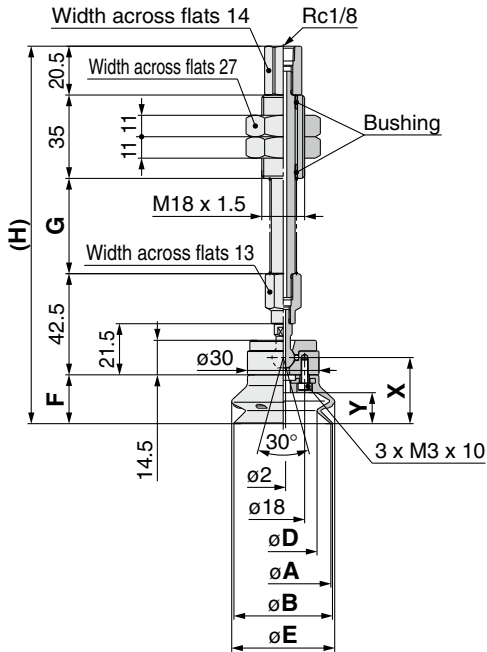

Dimensions

Model	A	B	D	E	F	G	H	X	Y
ZP2-TF40HB□(JB/JF)25						40	158.5		
ZP2-TF40HB□(JB/JF)50	40	41.4	28.3	42.3	20.5	75	193.5	27.8	13
ZP2-TF40HB□(JB/JF)75						111	229.5		
ZP2-TF50HB□(JB/JF)25						40	162		
ZP2-TF50HB□(JB/JF)50	50	52	36.2	52.7	24	75	197	31.3	16.5
ZP2-TF50HB□(JB/JF)75						111	233		

ZP2-TF⁶³₈₀HB□^{JB}_{JF}■

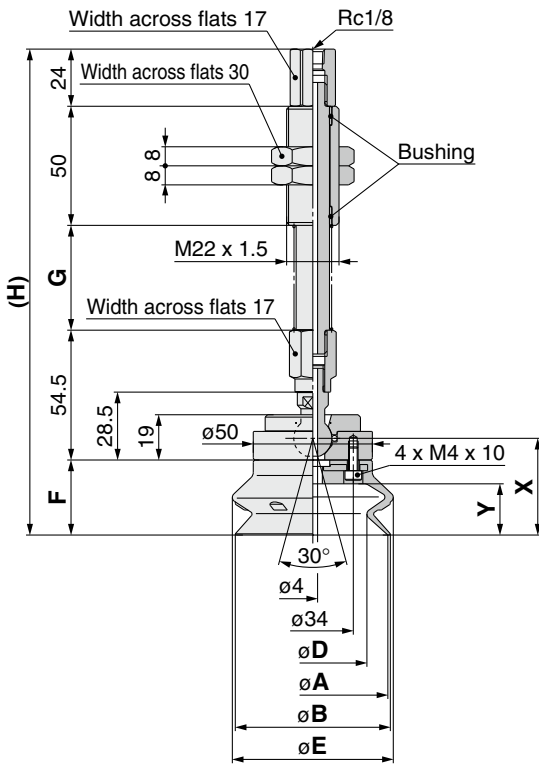

Dimensions

Model	A	B	D	E	F	G	H	X	Y
ZP2-TF63HB□(JB/JF)25						44	204		
ZP2-TF63HB□(JB/JF)50	63	65.1	46	66.4	31.5	80	240	40.6	21.5
ZP2-TF63HB□(JB/JF)75						120	280		
ZP2-TF63HB□(JB/JF)100						155	315		
ZP2-TF80HB□(JB/JF)25						44	209.5		
ZP2-TF80HB□(JB/JF)50	80	82.8	60.1	83.8	37	80	245.5	46.1	27.5
ZP2-TF80HB□(JB/JF)75						120	285.5		
ZP2-TF80HB□(JB/JF)100						155	320.5		

ZP2-TF¹⁰⁰₁₂₅HB□^{JB}_{JF}■

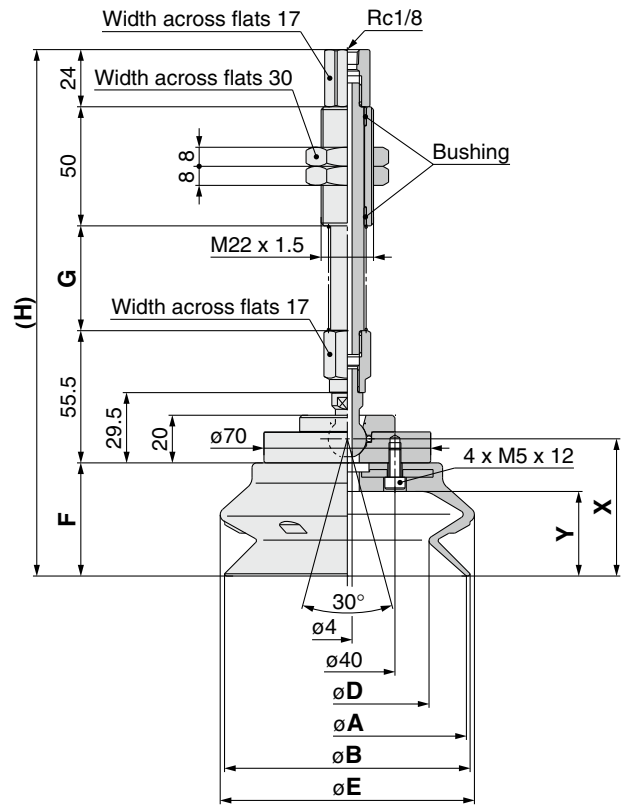

Dimensions

Model	A	B	D	E	F	G	H	X	Y
ZP2-TF100HB□(JB/JF)25						44	221		
ZP2-TF100HB□(JB/JF)50	100	103	72.5	103.9	47.5	80	257	57.6	35.5
ZP2-TF100HB□(JB/JF)75						120	297		
ZP2-TF100HB□(JB/JF)100						155	332		
ZP2-TF125HB□(JB/JF)25						44	229.5		
ZP2-TF125HB□(JB/JF)50	125	128.5	92.2	131.6	56	80	265.5	66.1	44
ZP2-TF125HB□(JB/JF)75						120	305.5		
ZP2-TF125HB□(JB/JF)100						155	340.5		

High Rigidity Ball Joint Pad **ZP2 Series**

How to Order

With buffer **ZP2 – X F 40 HB □ N JB 25**

• Vacuum inlet direction

Symbol	Direction
X	Lateral

• Specification (mechanism)

Symbol	Specification
F	Ball joint

• Pad diameter

Symbol	Pad diameter
40	ø40
50	ø50
63	ø63
80	ø80
100	ø100
125	ø125

• Pad form

Symbol	Form
HB	High rigidity (Bellows type)

• Buffer stroke (■)

Stroke	Pad diameter			
	ø40 ø50	ø63 ø80	ø100 ø125	
25	●	●	●	
50	●	●	●	
75	●	●	●	
100	—	●	●	

• Buffer specification

Symbol	Specification
JB	Rotating With bushing Material: Brass
JF	Rotating With bushing Material: Structural steel

• Pad material (□)

Symbol	Material
N	NBR
S	Silicone rubber*1*2
U	Urethane rubber
F	FKM
E	EPDM

*1 Compliant with the FDA (USA Food and Drug Administration) regulation 21CFR§177.2600 for "Rubber articles intended for repeated use"

*2 Compliant with the standards for "Rubber apparatus (excluding baby drinking apparatus) and containers/packaging" (D3) (Partial revision: Ministry of Health, Labour, and Welfare Notification No. 595, 2012) in Section 3 "Apparatus and Containers/Packaging" of the Food Sanitation Act, Article 18 "Specifications and Standards for Food and Food Additives, etc." (Ministry of Health and Welfare Notification No. 370, 1959).



Vacuum inlet direction **Lateral**

Replacement Part Nos.

Model	Pad unit part no.	Buffer assembly part no.	
ZP2-XF40HB□(JB/JF)25	ZP40HB□	ZP2B-XF1(JB/JF)25	With three M3 bolts
ZP2-XF40HB□(JB/JF)50		ZP2B-XF1(JB/JF)50	
ZP2-XF40HB□(JB/JF)75		ZP2B-XF1(JB/JF)75	
ZP2-XF50HB□(JB/JF)25	ZP50HB□	ZP2B-XF1(JB/JF)25	With four M4 bolts
ZP2-XF50HB□(JB/JF)50		ZP2B-XF1(JB/JF)50	
ZP2-XF50HB□(JB/JF)75		ZP2B-XF1(JB/JF)75	
ZP2-XF63HB□(JB/JF)25	ZP63HB□	ZP2B-XF2(JB/JF)25	With four M4 bolts
ZP2-XF63HB□(JB/JF)50		ZP2B-XF2(JB/JF)50	
ZP2-XF63HB□(JB/JF)75		ZP2B-XF2(JB/JF)75	
ZP2-XF63HB□(JB/JF)100	ZP80HB□	ZP2B-XF2(JB/JF)100	With four M5 bolts
ZP2-XF80HB□(JB/JF)25		ZP2B-XF2(JB/JF)25	
ZP2-XF80HB□(JB/JF)50		ZP2B-XF2(JB/JF)50	
ZP2-XF80HB□(JB/JF)75	ZP100HB□	ZP2B-XF2(JB/JF)75	With four M5 bolts
ZP2-XF80HB□(JB/JF)100		ZP2B-XF2(JB/JF)100	
ZP2-XF100HB□(JB/JF)25		ZP2B-XF3(JB/JF)25	
ZP2-XF100HB□(JB/JF)50	ZP125HB□	ZP2B-XF3(JB/JF)50	With four M5 bolts
ZP2-XF100HB□(JB/JF)75		ZP2B-XF3(JB/JF)75	
ZP2-XF100HB□(JB/JF)100		ZP2B-XF3(JB/JF)100	
ZP2-XF125HB□(JB/JF)25	ZP125HB□	ZP2B-XF3(JB/JF)25	With four M5 bolts
ZP2-XF125HB□(JB/JF)50		ZP2B-XF3(JB/JF)50	
ZP2-XF125HB□(JB/JF)75		ZP2B-XF3(JB/JF)75	
ZP2-XF125HB□(JB/JF)100		ZP2B-XF3(JB/JF)100	

* □ in the table indicates the pad material

Buffer Specifications

Pad diameter		ø40, ø50	ø63, ø80, ø100, ø125
Stroke [mm]		25, 50, 75	25, 50, 75, 100
Spring reactive force [N]	At 0 stroke	6.9	10
	At full stroke	11.8	15
Buffer specifications	JB	Rotating With bushing Buffer body material: Brass Nut tightening torque: 28 to 32 N·m Nut tightening torque: 45 to 50 N·m	
	JF	Rotating With bushing Buffer body material: Structural steel Nut tightening torque: 48 to 52 N·m Nut tightening torque: 75 to 80 N·m	

Dimensions: With Buffer

ZP2-XF⁴⁰₅₀HB □ JB/JF ■

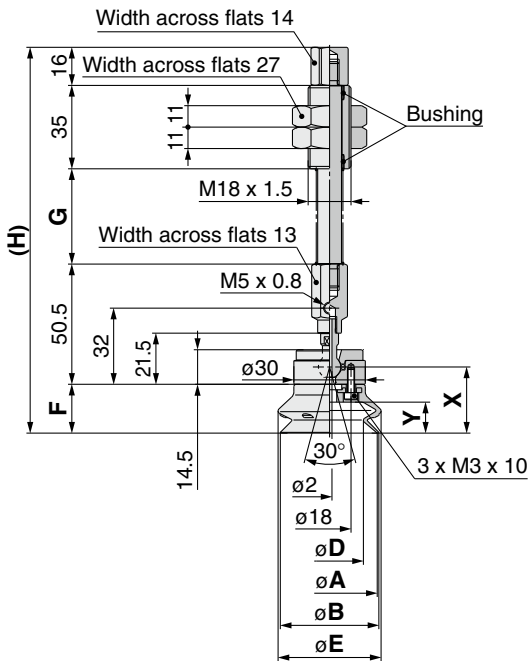

Dimensions

Model	A	B	D	E	F	G	H	X	Y
ZP2-XF40HB□(JB/JF)25						40	162		
ZP2-XF40HB□(JB/JF)50	40	41.4	28.3	42.3	20.5	75	197	27.8	13
ZP2-XF40HB□(JB/JF)75						111	233		
ZP2-XF50HB□(JB/JF)25						40	165.5		
ZP2-XF50HB□(JB/JF)50	50	52	36.2	52.7	24	75	200.5	31.3	16.5
ZP2-XF50HB□(JB/JF)75						111	236.5		

ZP2-XF⁶³₈₀HB □ JB/JF ■

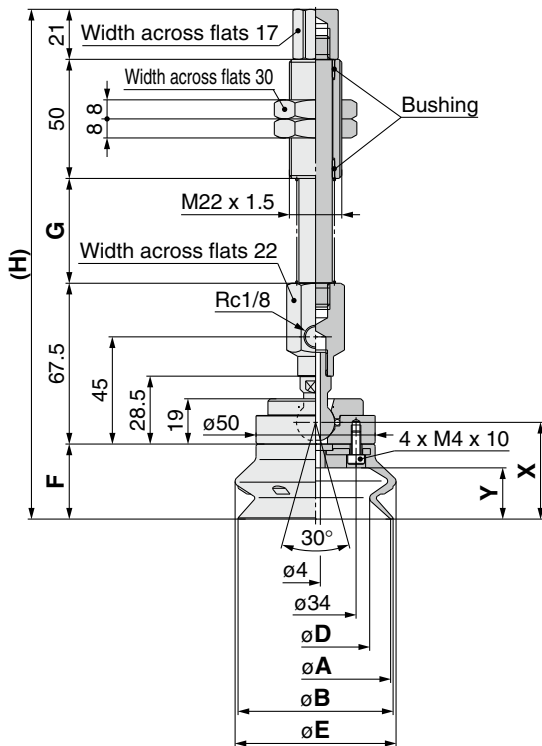

Dimensions

Model	A	B	D	E	F	G	H	X	Y
ZP2-XF63HB□(JB/JF)25						44	214		
ZP2-XF63HB□(JB/JF)50	63	65.1	46	66.4	31.5	80	250	40.6	21.5
ZP2-XF63HB□(JB/JF)75						120	290		
ZP2-XF63HB□(JB/JF)100						155	325		
ZP2-XF80HB□(JB/JF)25						44	219.5		
ZP2-XF80HB□(JB/JF)50	80	82.8	60.1	83.8	37	80	255.5	46.1	27.5
ZP2-XF80HB□(JB/JF)75						120	295.5		
ZP2-XF80HB□(JB/JF)100						155	330.5		

ZP2-XF¹⁰⁰₁₂₅HB □ JB/JF ■

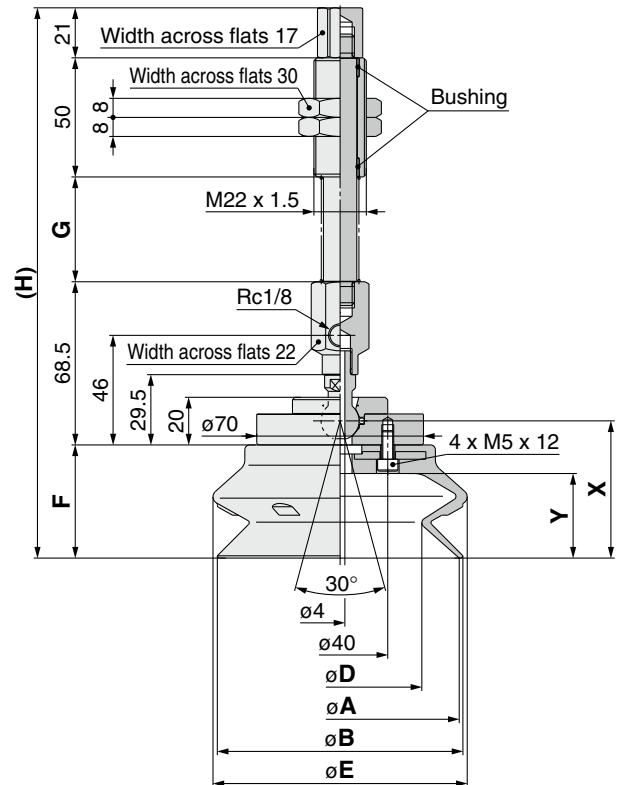

Dimensions

Model	A	B	D	E	F	G	H	X	Y
ZP2-XF100HB□(JB/JF)25						44	231		
ZP2-XF100HB□(JB/JF)50	100	103	72.5	103.9	47.5	80	267	57.6	35.5
ZP2-XF100HB□(JB/JF)75						120	307		
ZP2-XF100HB□(JB/JF)100						155	342		
ZP2-XF125HB□(JB/JF)25						44	239.5		
ZP2-XF125HB□(JB/JF)50	125	128.5	92.2	131.6	56	80	275.5	66.1	44
ZP2-XF125HB□(JB/JF)75						120	315.5		
ZP2-XF125HB□(JB/JF)100						155	350.5		

High Rigidity Pad

Pad diameter $\varnothing 40, \varnothing 50, \varnothing 63, \varnothing 80, \varnothing 100, \varnothing 125$

Symbol/Form

H: High rigidity
(Flat type with ribs)
HB: High rigidity
(Bellows type)

■ Reinforced pad prevents deformation when transferring heavy or large workpieces.

How to Order

Pad unit **ZP 40 H N**

Symbol	Pad diameter
40	$\varnothing 40$
50	$\varnothing 50$
63	$\varnothing 63$
80	$\varnothing 80$
100	$\varnothing 100$
125	$\varnothing 125$

Pad material

Symbol	Material
N	NBR
S	Silicone rubber*1*2
U	Urethane rubber
F	FKM
E	EPDM

*1 Compliant with the FDA (USA Food and Drug Administration) regulation 21CFR§177.2600 for "Rubber articles intended for repeated use"

*2 Compliant with the standards for "Rubber apparatus (excluding baby drinking apparatus) and containers/packaging" (D3) (Partial revision: Ministry of Health, Labour, and Welfare Notification No. 595, 2012) in Section 3 "Apparatus and Containers/Packaging" of the Food Sanitation Act, Article 18 "Specifications and Standards for Food and Food Additives, etc." (Ministry of Health and Welfare Notification No. 370, 1959)

Pad form

Symbol	Form
H	High rigidity (Flat type with ribs)
HB	High rigidity (Bellows type)

Dimensions: Pad Unit

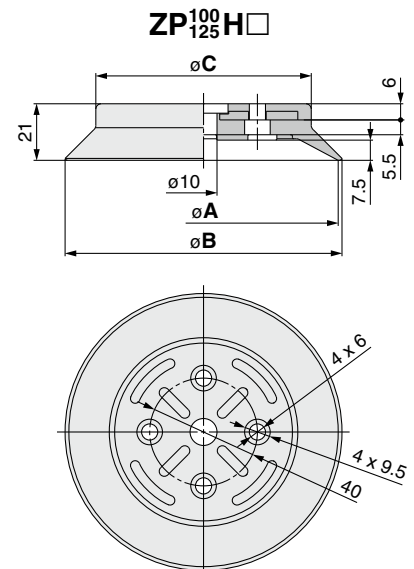
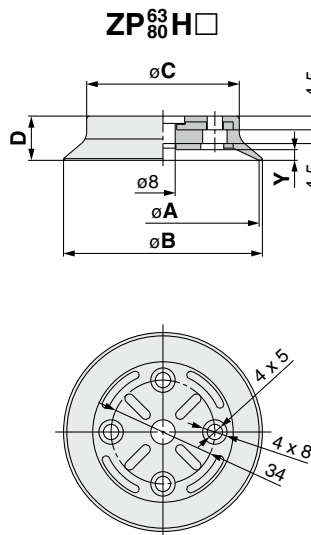
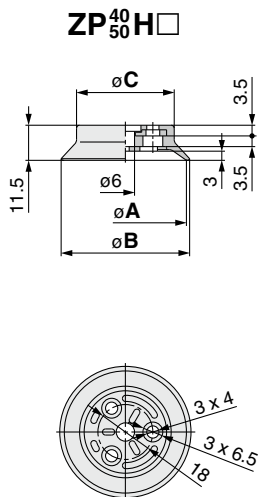

Dimensions

Model	A	B	C
ZP40H□	40	42.1	32
ZP50H□	50	52.1	42

Dimensions

Model	A	B	C	D	Y
ZP63H□	63	65.2	50	14.5	3.5
ZP80H□	80	82.1	61	16.5	4.5

Dimensions

Model	A	B	C
ZP100H□	100	102.8	80
ZP125H□	125	127.7	104

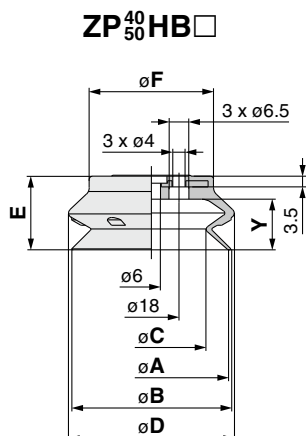

Dimensions

Model	A	B	C	D	E	F	Y
ZP40HB□	40	41.4	28.3	42.3	20.5	30	13
ZP50HB□	50	52	36.2	52.7	24	40.5	16.5

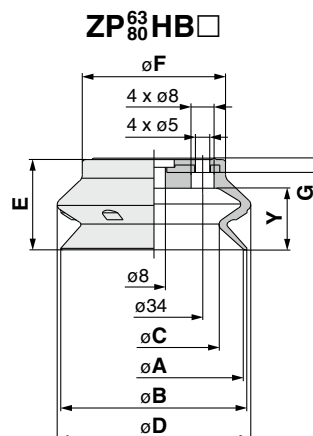

Dimensions

Model	A	B	C	D	E	F	G	Y
ZP63HB□	63	65.1	46	66.4	31.5	50	4.5	21.5
ZP80HB□	80	82.8	60.1	83.8	37	64	5	27.5

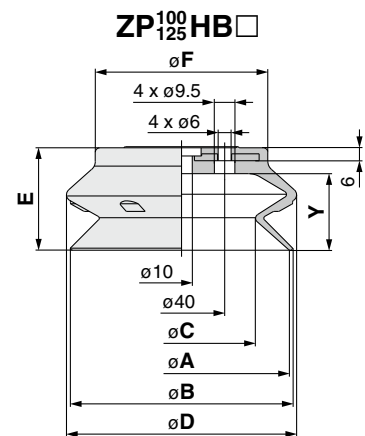

Dimensions

Model	A	B	C	D	E	F	Y
ZP100HB□	100	103	72.5	103.9	47.5	80	35.5
ZP125HB□	125	128.5	92.2	131.6	56	105	44

How to Order

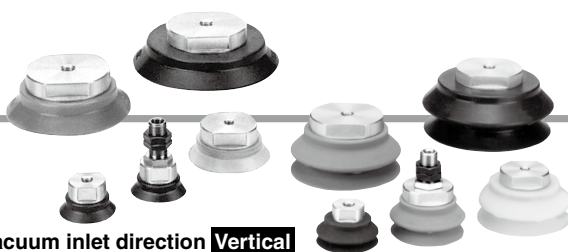

With adapter **ZPT 40 H N - A14**

Pad diameter

Symbol	Pad diameter
40	ø40
50	ø50
63	ø63
80	ø80
100	ø100
125	ø125

Pad form (*)

Symbol	Form
H	High rigidity (Flat type with ribs)
HB	High rigidity (Bellows type)

Pad material (□)

Symbol	Material
N	NBR
S	Silicone rubber*1*2
U	Urethane rubber
F	FKM
E	EPDM

*1 Compliant with the FDA (USA Food and Drug Administration) regulation 21CFR§177.2600 for "Rubber articles intended for repeated use"

*2 Compliant with the standards for "Rubber apparatus (excluding baby drinking apparatus) and containers/packaging" (D3) (Partial revision: Ministry of Health, Labour, and Welfare Notification No. 595, 2012) in Section 3 "Apparatus and Containers/Packaging" of the Food Sanitation Act, Article 18 "Specifications and Standards for Food and Food Additives, etc." (Ministry of Health and Welfare Notification No. 370, 1959).

Mounting thread size (Vacuum inlet)

Mounting	Thread size	Symbol	Pad diameter			
			ø40, ø50	ø63, ø80	ø100, ø125	
Male thread	M14 x 1	A14	Rc1/8	●	—	—
		A14N	NPT1/8	●	—	—
		A14T	NPTF1/8	●	—	—
	M16 x 1.5	A16	Rc1/8	—	●	●
		A16N	NPT1/8	—	●	●
		A16T	NPTF1/8	—	●	●
Female thread	B8	M8 x 1.25	●	●	—	
	B10	M10 x 1.5	●	●	—	
	B12	M12 x 1.75	—	●	●	
	B16	M16 x 1.5	—	●	●	

Vacuum inlet direction **Vertical**

Replacement Part Nos.

Model	Pad unit part no.	Adapter assembly part no.	Model	Pad unit part no.	Adapter assembly part no.
ZPT40*□-A14		ZPA-T1-B01	ZPT40*□-B8		ZPA-T1-B8
ZPT40*□-A14N	ZP40*□	ZPA-T1-N01	ZPT40*□-B10	ZP40*□	ZPA-T1-B10
ZPT40*□-A14T		ZPA-T1-T01	ZPT50*□-B8		ZPA-T1-B8
ZPT50*□-A14	ZP50*□	ZPA-T1-N01	ZPT50*□-B10	ZP50*□	ZPA-T1-B10
ZPT50*□-A14N		ZPA-T1-T01	ZPT63*□-B8		ZPA-T2-B8
ZPT50*□-A14T		ZPA-T1-T01	ZPT63*□-B10	ZP63*□	ZPA-T2-B10
ZPT63*□-A16	ZP63*□	ZPA-T2-B01	ZPT63*□-B12		ZPA-T2-B12
ZPT63*□-A16N		ZPA-T2-N01	ZPT63*□-B16		ZPA-T2-B16
ZPT63*□-A16T		ZPA-T2-T01	ZPT80*□-B8		ZPA-T2-B8
ZPT80*□-A16	ZP80*□	ZPA-T2-B01	ZPT80*□-B10	ZP80*□	ZPA-T2-B10
ZPT80*□-A16N		ZPA-T2-N01	ZPT80*□-B12		ZPA-T2-B12
ZPT80*□-A16T		ZPA-T2-T01	ZPT80*□-B16		ZPA-T2-B16
ZPT100*□-A16	ZP100*□	ZPA-T3-B01	ZPT100*□-B12	ZP100*□	ZPA-T3-B12
ZPT100*□-A16N		ZPA-T3-N01	ZPT100*□-B16		ZPA-T3-B16
ZPT100*□-A16T		ZPA-T3-T01	ZPT125*□-B12	ZP125*□	ZPA-T3-B12
ZPT125*□-A16	ZP125*□	ZPA-T3-B01	ZPT125*□-B16		ZPA-T3-B16
ZPT125*□-A16N		ZPA-T3-N01			
ZPT125*□-A16T		ZPA-T3-T01			

* * in the table indicates the pad form

* □ in the table indicates the pad material

Dimensions: With Adapter

ZPT₄₀H□-A14 (Male thread)

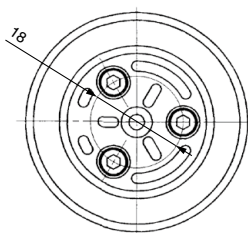
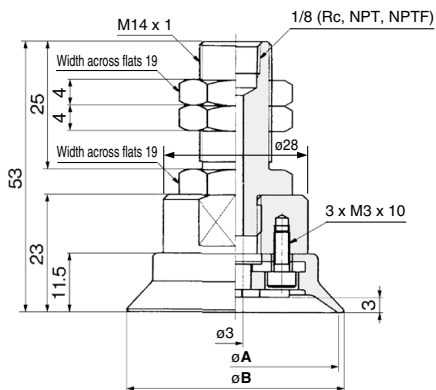

ZPT₆₃H□-A16 (Male thread)

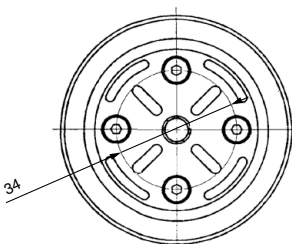
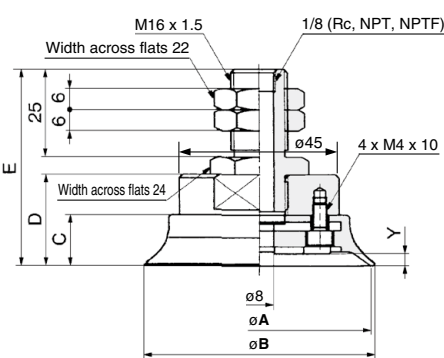

ZPT₁₀₀H□-A16 (Male thread)

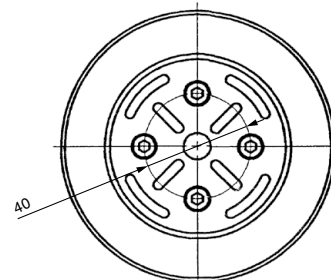
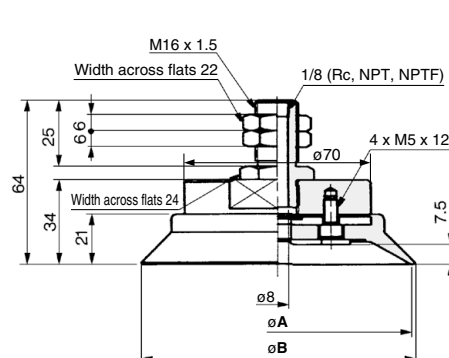

Dimensions

Model	A	B
ZPT40H□-A14	40	42.1
ZPT50H□-A14	50	52.1

Dimensions

Model	A	B	C	D	E	Y
ZPT63H□-A16	63	65.2	14.5	26	56	3.5
ZPT80H□-A16	80	82.1	16.5	28	58	4.5

Dimensions

Model	A	B
ZPT100H□-A16	100	102.8
ZPT125H□-A16	125	127.7

High Rigidity Pad **ZP Series**

Dimensions: With Adapter

ZPT₅₀⁴⁰HB□-A14 (Male thread)

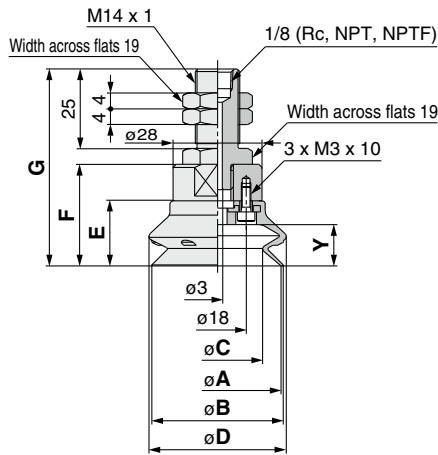

Dimensions

Model	A	B	C	D
ZPT40HB□-A14	40	41.4	28.3	42.3
ZPT50HB□-A14	50	52	36.2	52.7

Model	E	F	G	Y
ZPT40HB□-A14	20.5	32	62	13
ZPT50HB□-A14	24	35.5	65.5	16.5

ZPT₈₀⁶³HB□-A16 (Male thread)

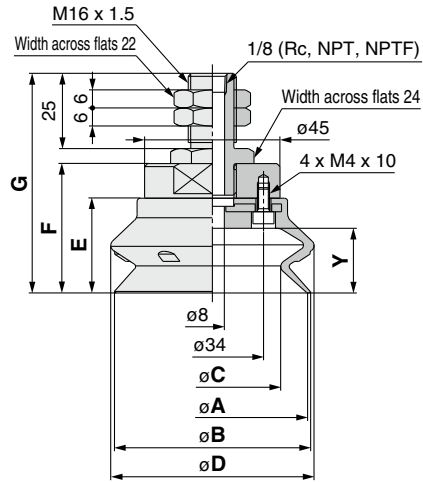

Dimensions

Model	A	B	C	D
ZPT63HB□-A16	63	65.1	46	66.4
ZPT80HB□-A16	80	82.8	60.1	83.8

Model	E	F	G	Y
ZPT63HB□-A16	31.5	43	73	21.5
ZPT80HB□-A16	37	48.5	78.5	27.5

ZPT₁₂₅¹⁰⁰HB□-A16 (Male thread)

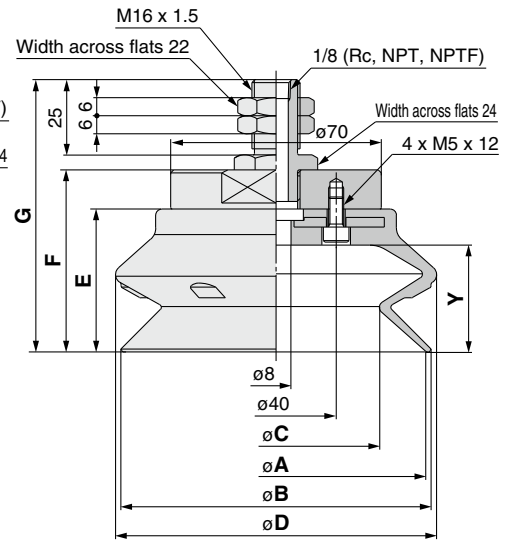

Dimensions

Model	A	B	C	D
ZPT100HB□-A16	100	103	72.5	103.9
ZPT125HB□-A16	125	128.5	92.2	131.6

Model	E	F	G	Y
ZPT100HB□-A16	47.5	60.5	90.5	35.5
ZPT125HB□-A16	56	69	99	44

ZPT₅₀⁴⁰H□-B□ (Female thread)

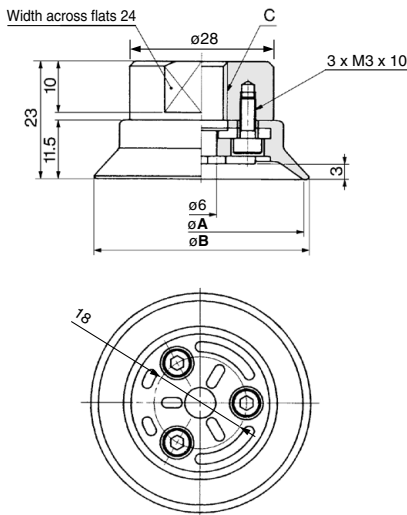

ZPT₈₀⁶³H□-B□ (Female thread)

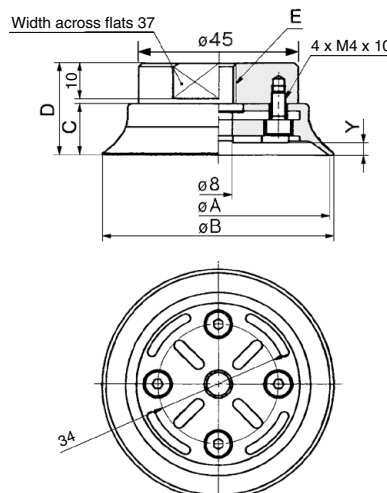

Dimensions

Model	A	B	C
ZPT40H□-B8	40	42.1	M8 x 1.25
ZPT40H□-B10			M10 x 1.5
ZPT50H□-B8	50	52.1	M8 x 1.25
ZPT50H□-B10			M10 x 1.5

Dimensions

Model	A	B	C	D	E	Y
ZPT63H□-B8	63	65.2	14.5	26	M8 x 1.25	3.5
ZPT63H□-B10					M10 x 1.5	
ZPT63H□-B12					M12 x 1.75	
ZPT63H□-B16	80	82.1	16.5	28	M16 x 1.5	4.5
ZPT80H□-B8					M8 x 1.25	
ZPT80H□-B10					M10 x 1.5	
ZPT80H□-B12					M12 x 1.75	
ZPT80H□-B16					M16 x 1.5	

Dimensions: With Adapter

ZPT¹⁰⁰₁₂₅H□-B□ (Female thread)

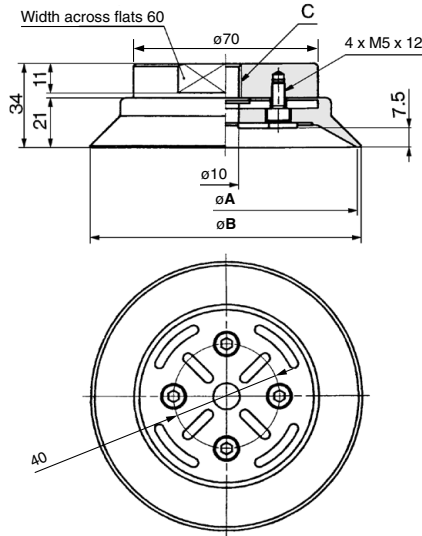

Dimensions

Model	A	B	C
ZPT100H□-B12	100	102.8	M12 x 1.75
ZPT100H□-B16			M16 x 1.5
ZPT125H□-B12	125	127.7	M12 x 1.75
ZPT125H□-B16			M16 x 1.5

ZPT⁴⁰₅₀HB□-B□ (Female thread)

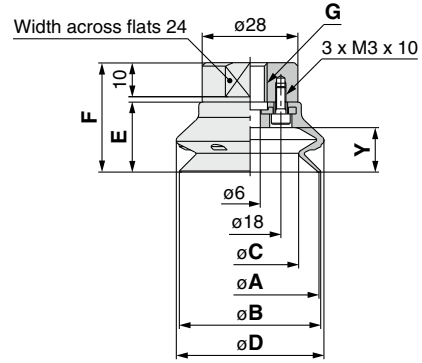

Dimensions

Model	A	B	C	D	E	F	G	Y
ZPT40HB□-B8	40	41.4	28.3	42.3	20.5	32	M8 x 1.25	13
ZPT40HB□-B10							M10 x 1.5	
ZPT50HB□-B8	50	52	36.2	52.7	24	35.5	M8 x 1.25	16.5
ZPT50HB□-B10							M10 x 1.5	

ZPT⁶³₈₀HB□-B□ (Female thread)

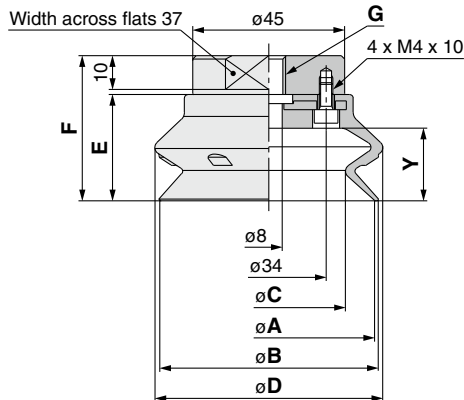

Dimensions

Model	A	B	C	D	E	F	G	Y
ZPT63HB□-B8	63	65.1	46	66.4	31.5	43	M8 x 1.25	21.5
ZPT63HB□-B10							M10 x 1.5	
ZPT63HB□-B12							M12 x 1.75	
ZPT63HB□-B16							M16 x 1.5	
ZPT80HB□-B8	80	82.8	60.1	83.8	37	48.5	M8 x 1.25	27.5
ZPT80HB□-B10							M10 x 1.5	
ZPT80HB□-B12							M12 x 1.75	
ZPT80HB□-B16							M16 x 1.5	

ZPT¹⁰⁰₁₂₅HB□-B□ (Female thread)

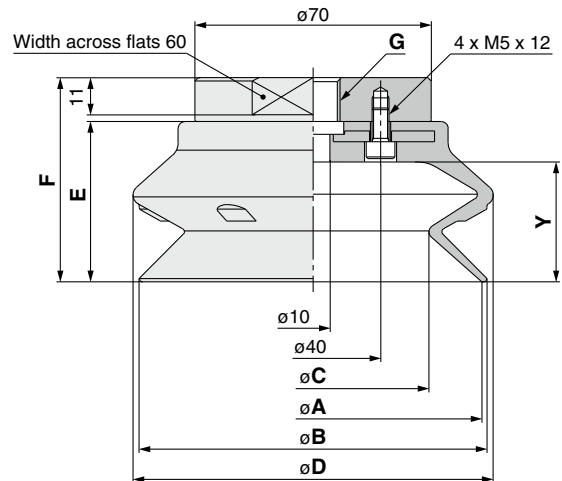

Dimensions

Model	A	B	C	D	E	F	G	Y
ZPT100HB□-B12	100	103	72.5	103.9	47.5	60.5	M12 x 1.75	35.5
ZPT100HB□-B16							M16 x 1.5	
ZPT125HB□-B12	125	128.5	92.2	131.6	56	69	M12 x 1.75	44
ZPT125HB□-B16							M16 x 1.5	

High Rigidity Pad **ZP Series**

How to Order

With adapter **ZPX 40 H N - B01 - B8**

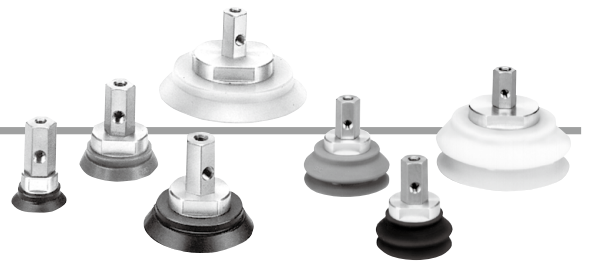

Vacuum inlet direction **Lateral**

Pad diameter

Symbol	Pad diameter
40	ø40
50	ø50
63	ø63
80	ø80
100	ø100
125	ø125

Pad form (*)

Symbol	Form
H	High rigidity (Flat type with ribs)
HB	High rigidity (Bellows type)

Vacuum inlet thread size

Symbol	Thread size
B01	Rc1/8
N01	NPT1/8
T01	NPTF1/8

Mounting thread size

Symbol	Thread size	Pad diameter		
		ø40, ø50	ø63, ø80	ø100, ø125
B8	M8 x 1.25	●	—	—
B10	M10 x 1.5	●	●	●
B12	M12 x 1.75	—	●	●

Pad material (□)

Symbol	Material
N	NBR
S	Silicone rubber*1*2
U	Urethane rubber
F	FKM
E	EPDM

Replacement Part Nos.

Model	Pad unit part no.	Adapter assembly part no.	Model	Pad unit part no.	Adapter assembly part no.
ZPX40*□-B01-B8	ZP40*□	ZPA-X1-B01-B8	ZPX80*□-B01-B10	ZP80*□	ZPA-X2-B01-B10
ZPX40*□-N01-B8		ZPA-X1-N01-B8	ZPX80*□-N01-B10		ZPA-X2-N01-B10
ZPX40*□-T01-B8		ZPA-X1-T01-B8	ZPX80*□-T01-B10		ZPA-X2-T01-B10
ZPX40*□-B01-B10		ZPA-X1-B01-B10	ZPX80*□-B01-B12		ZPA-X2-B01-B12
ZPX40*□-N01-B10		ZPA-X1-N01-B10	ZPX80*□-N01-B12		ZPA-X2-N01-B12
ZPX40*□-T01-B10	ZPA-X1-T01-B10	ZPX80*□-T01-B12	ZPA-X2-T01-B12		
ZPX50*□-B01-B8	ZP50*□	ZPA-X1-B01-B8	ZPX100*□-B01-B10	ZP100*□	ZPA-X3-B01-B10
ZPX50*□-N01-B8		ZPA-X1-N01-B8	ZPX100*□-N01-B10		ZPA-X3-N01-B10
ZPX50*□-T01-B8		ZPA-X1-T01-B8	ZPX100*□-T01-B10		ZPA-X3-T01-B10
ZPX50*□-B01-B10		ZPA-X1-B01-B10	ZPX100*□-B01-B12		ZPA-X3-B01-B12
ZPX50*□-N01-B10		ZPA-X1-N01-B10	ZPX100*□-N01-B12		ZPA-X3-N01-B12
ZPX50*□-T01-B10	ZPA-X1-T01-B10	ZPX100*□-T01-B12	ZPA-X3-T01-B12		
ZPX63*□-B01-B10	ZP63*□	ZPA-X2-B01-B10	ZPX125*□-B01-B10	ZP125*□	ZPA-X3-B01-B10
ZPX63*□-N01-B10		ZPA-X2-N01-B10	ZPX125*□-N01-B10		ZPA-X3-N01-B10
ZPX63*□-T01-B10		ZPA-X2-T01-B10	ZPX125*□-T01-B10		ZPA-X3-T01-B10
ZPX63*□-B01-B12		ZPA-X2-B01-B12	ZPX125*□-B01-B12		ZPA-X3-B01-B12
ZPX63*□-N01-B12		ZPA-X2-N01-B12	ZPX125*□-N01-B12		ZPA-X3-N01-B12
ZPX63*□-T01-B12	ZPA-X2-T01-B12	ZPX125*□-T01-B12	ZPA-X3-T01-B12		

*1 Compliant with the FDA (USA Food and Drug Administration) regulation 21CFR§177.2600 for "Rubber articles intended for repeated use"

*2 Compliant with the standards for "Rubber apparatus (excluding baby drinking apparatus) and containers/packaging" (D3) (Partial revision: Ministry of Health, Labour, and Welfare Notification No. 595, 2012) in Section 3 "Apparatus and Containers/Packaging" of the Food Sanitation Act, Article 18 "Specifications and Standards for Food and Food Additives, etc." (Ministry of Health and Welfare Notification No. 370, 1959).

* * in the table indicates the pad form

* □ in the table indicates the pad material

Dimensions: With Adapter

ZPX₅₀⁴⁰H□-□01-B₈^{B10}

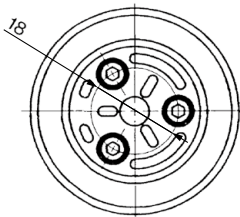
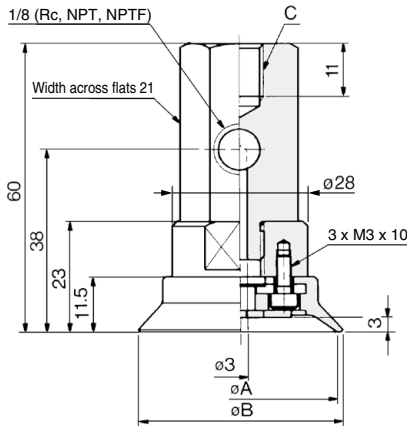

ZPX₈₀⁶³H□-□01-B₁₀^{B12}

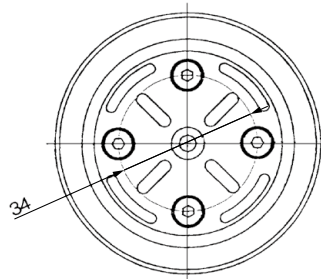
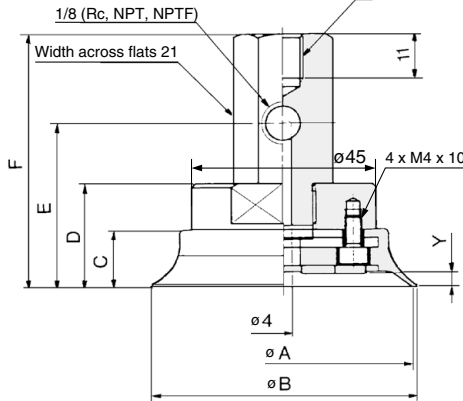

ZPX₁₂₅¹⁰⁰H□-□01-B₁₀^{B12}

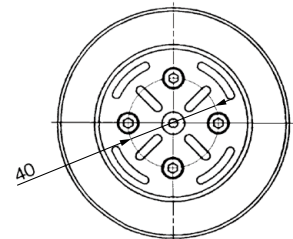
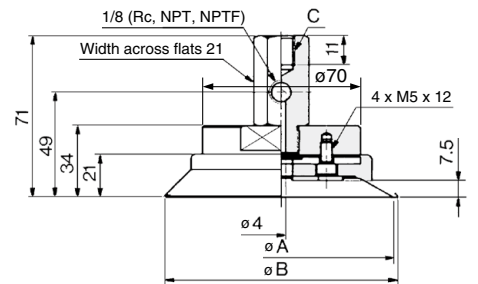

Dimensions

Model	A	B	C
ZPX40H□-□01-B8	40	42.1	M8 x 1.25
ZPX40H□-□01-B10			M10 x 1.5
ZPX50H□-□01-B8	50	52.1	M8 x 1.25
ZPX50H□-□01-B10			M10 x 1.5

Dimensions

Model	A	B	C	D	E	F	Y	G
ZPX63H□-□01-B10	63	65.2	14.5	26	41	63	3.5	M10 x 1.5
ZPX63H□-□01-B12								M12 x 1.75
ZPX80H□-□01-B10	80	82.1	16.5	28	43	65	4.5	M10 x 1.5
ZPX80H□-□01-B12								M12 x 1.75

Dimensions

Model	A	B	C
ZPX100H□-□01-B10	100	102.8	M10 x 1.5
ZPX100H□-□01-B12			M12 x 1.75
ZPX125H□-□01-B10	125	127.7	M10 x 1.5
ZPX125H□-□01-B12			M12 x 1.75

Dimensions: With Adapter

ZPX₅₀⁴⁰HB□-□01-B8/B10

ZPX₈₀⁶³HB□-□01-B10/B12

ZPX₁₂₅¹⁰⁰HB□-□01-B10/B12

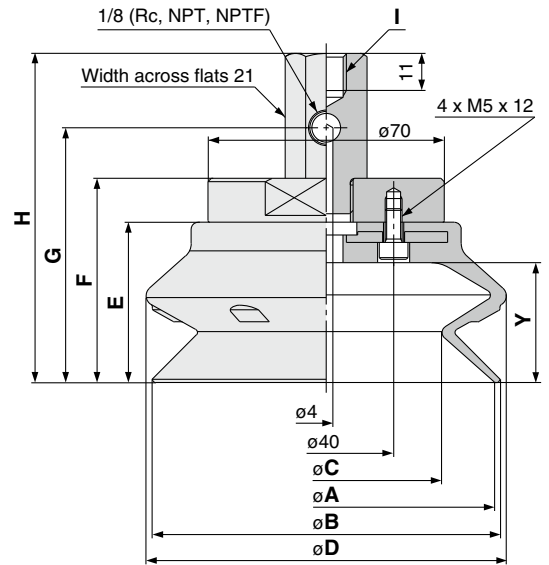
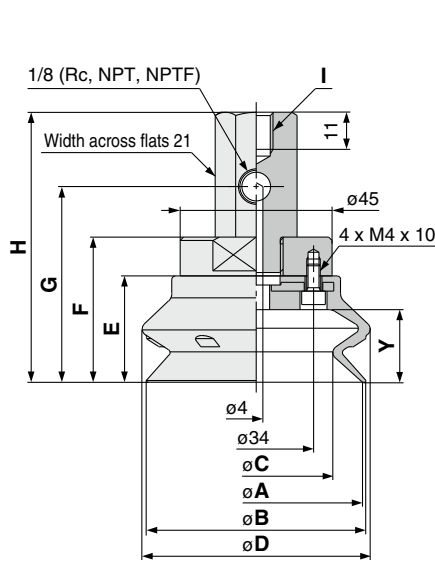
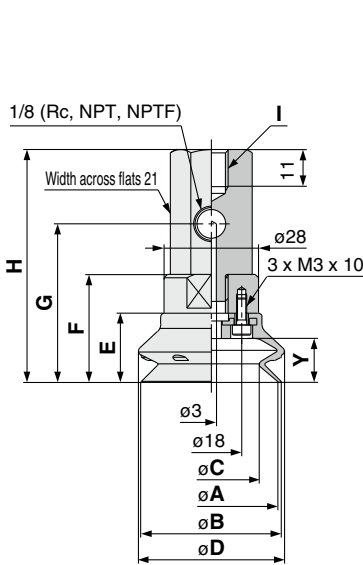

Dimensions

Model	A	B	C	D	E	F
ZPX40HB□-□01-B8	40	41.4	28.3	42.3	20.5	32
ZPX40HB□-□01-B10						
ZPX50HB□-□01-B8	50	52	36.2	52.7	24	35.5
ZPX50HB□-□01-B10						

Model	G	H	I	Y
ZPX40HB□-□01-B8	47	69	M8 x 1.25	13
ZPX40HB□-□01-B10			M10 x 1.5	
ZPX50HB□-□01-B8	50.5	72.5	M8 x 1.25	16.5
ZPX50HB□-□01-B10			M10 x 1.5	

Dimensions

Model	A	B	C	D	E	F
ZPX63HB□-□01-B10	63	65.1	46	66.4	31.5	43
ZPX63HB□-□01-B12						
ZPX80HB□-□01-B10	80	82.8	60.1	83.8	37	48.5
ZPX80HB□-□01-B12						

Model	G	H	I	Y
ZPX63HB□-□01-B10	58	80	M10 x 1.5	21.5
ZPX63HB□-□01-B12			M12 x 1.75	
ZPX80HB□-□01-B10	63.5	85.5	M10 x 1.5	27.5
ZPX80HB□-□01-B12			M12 x 1.75	

Dimensions

Model	A	B	C	D	E	F
ZPX100HB□-□01-B10	100	103	72.5	103.9	47.5	60.5
ZPX100HB□-□01-B12						
ZPX125HB□-□01-B10	125	128.5	92.2	131.6	56	69
ZPX125HB□-□01-B12						

Model	G	H	I	Y
ZPX100HB□-□01-B10	75.5	97.5	M10 x 1.5	35.5
ZPX100HB□-□01-B12			M12 x 1.75	
ZPX125HB□-□01-B10	84	106	M10 x 1.5	44
ZPX125HB□-□01-B12			M12 x 1.75	

Made to Order

ZP2V

XT661

MHM

High Rigidity Pad **ZP Series**

How to Order

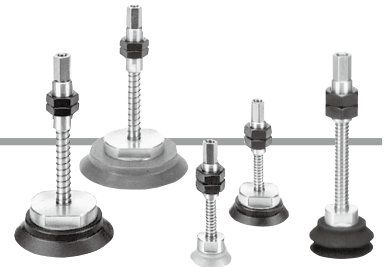

Vacuum inlet direction **Vertical**

With buffer **ZPT 40 H N J 25 - B01 - A18**

Symbol	Pad diameter
40	ø40
50	ø50
63	ø63
80	ø80
100	ø100
125	ø125

Symbol	Form
H	High rigidity (Flat type with ribs)
HB	High rigidity (Bellows type)

Symbol	Thread size
B01	Rc1/8
N01	NPT1/8
T01	NPTF1/8

Symbol	Thread size
A18	M18 x 1.5 (ø40 to ø80)
A22	M22 x 1.5 (ø100, ø125)

Symbol	Material
N	NBR
S	Silicone rubber*1*2
U	Urethane rubber
F	FKM
E	EPDM

Symbol	Material
J	Aluminum alloy
JB	Brass + With bushing
JF	Structural steel + With bushing

Stroke	ø40	ø50	ø63	ø80	ø100	ø125
25	●	●	●	●	●	●
50	●	●	●	●	●	●
75	●	●	●	●	●	●
100	—	—	—	—	●	●

*1 Compliant with the FDA (USA Food and Drug Administration) regulation 21CFR§177.2600 for "Rubber articles intended for repeated use"
 *2 Compliant with the standards for "Rubber apparatus (excluding baby drinking apparatus) and containers/packaging" (D3) (Partial revision: Ministry of Health, Labour, and Welfare Notification No. 595, 2012) in Section 3 "Apparatus and Containers/Packaging" of the Food Sanitation Act, Article 18 "Specifications and Standards for Food and Food Additives, etc." (Ministry of Health and Welfare Notification No. 370, 1959).

Buffer Specifications (Rotating)

Pad diameter		ø40 to ø80	ø100, ø125
Stroke [mm]	At 0 stroke	25, 50, 75	25, 50, 75, 100
Spring reactive force [N]	At full stroke	6.9	10
		11.8	15

Mounting thread size	Nut Tightening Torque [N·m]		
	Aluminum alloy	Brass + With bushing	Structural steel + With bushing
M18 x 1.5	9.5 to 10.5	28 to 32	48 to 52
M22 x 1.5	9.5 to 10.5	45 to 50	75 to 80

Replacement Part Nos.

Model	Pad unit part no.	Buffer assembly part no.
ZPT40*□★25-(B/N/T)01-A18	ZP40*□	ZPB-T1★25-(B/N/T)01
ZPT40*□★50-(B/N/T)01-A18		ZPB-T1★50-(B/N/T)01
ZPT40*□★75-(B/N/T)01-A18		ZPB-T1★75-(B/N/T)01
ZPT50*□★25-(B/N/T)01-A18	ZP50*□	ZPB-T1★25-(B/N/T)01
ZPT50*□★50-(B/N/T)01-A18		ZPB-T1★50-(B/N/T)01
ZPT50*□★75-(B/N/T)01-A18		ZPB-T1★75-(B/N/T)01
ZPT63*□★25-(B/N/T)01-A18	ZP63*□	ZPB-T2★25-(B/N/T)01
ZPT63*□★50-(B/N/T)01-A18		ZPB-T2★50-(B/N/T)01
ZPT63*□★75-(B/N/T)01-A18		ZPB-T2★75-(B/N/T)01
ZPT80*□★25-(B/N/T)01-A18	ZP80*□	ZPB-T2★25-(B/N/T)01
ZPT80*□★50-(B/N/T)01-A18		ZPB-T2★50-(B/N/T)01
ZPT80*□★75-(B/N/T)01-A18		ZPB-T2★75-(B/N/T)01
ZPT100*□★25-(B/N/T)01-A22	ZP100*□	ZPB-T3★25-(B/N/T)01
ZPT100*□★50-(B/N/T)01-A22		ZPB-T3★50-(B/N/T)01
ZPT100*□★75-(B/N/T)01-A22		ZPB-T3★75-(B/N/T)01
ZPT100*□★100-(B/N/T)01-A22	ZP100*□	ZPB-T3★100-(B/N/T)01
ZPT125*□★25-(B/N/T)01-A22		ZPB-T3★25-(B/N/T)01
ZPT125*□★50-(B/N/T)01-A22		ZPB-T3★50-(B/N/T)01
ZPT125*□★75-(B/N/T)01-A22	ZP125*□	ZPB-T3★75-(B/N/T)01
ZPT125*□★100-(B/N/T)01-A22		ZPB-T3★100-(B/N/T)01

* in the table indicates the pad form
 □ in the table indicates the pad material
 ★ in the table indicates the buffer body material

Dimensions: With Buffer

ZPT₅₀⁴⁰H□★■-□01-A18

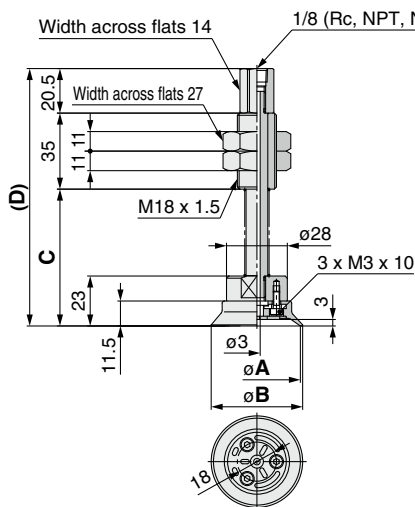

Dimensions

Model	A	B	C	D
ZPT40H□★25-□01-A18		63	118.5	
ZPT40H□★50-□01-A18	40	42.1	98	153.5
ZPT40H□★75-□01-A18		134	189.5	
ZPT50H□★25-□01-A18		63	118.5	
ZPT50H□★50-□01-A18	50	52.1	98	153.5
ZPT50H□★75-□01-A18		134	189.5	

ZPT₈₀⁶³H□★■-□01-A18

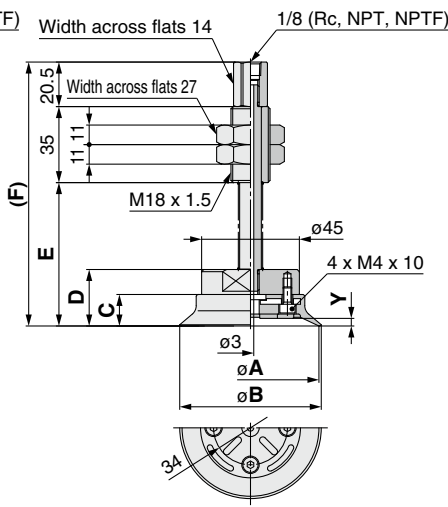

Dimensions

Model	A	B	C	D	E	F	Y
ZPT63H□★25-□01-A18					66	121.5	
ZPT63H□★50-□01-A18	63	65.2	14.5	26	101	156.5	3.5
ZPT63H□★75-□01-A18					137	192.5	
ZPT80H□★25-□01-A18					68	123.5	
ZPT80H□★50-□01-A18	80	82.1	16.5	28	103	158.5	4.5
ZPT80H□★75-□01-A18					139	194.5	

ZPT₁₂₅¹⁰⁰H□★■-□01-A22

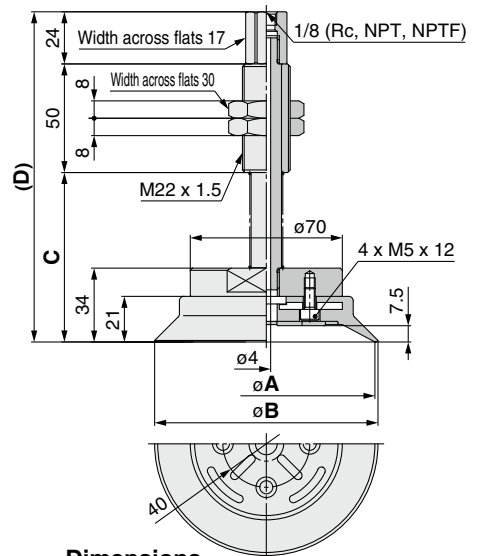

Dimensions

Model	A	B	C	D
ZPT100H□★25-□01-A22			78	152
ZPT100H□★50-□01-A22	100	102.8	114	188
ZPT100H□★75-□01-A22			154	228
ZPT100H□★100-□01-A22			189	263
ZPT125H□★25-□01-A22			78	152
ZPT125H□★50-□01-A22	125	127.7	114	188
ZPT125H□★75-□01-A22			154	228
ZPT125H□★100-□01-A22			189	263

Dimensions: With Buffer

Made to Order

ZP2V

XT661

MHM

Precautions

ZPT₅₀⁴⁰HB \square \star \blacksquare \square 01-A18

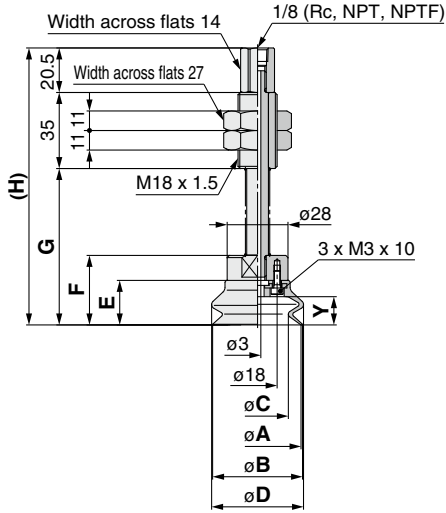

Dimensions

Model	A	B	C	D	E
ZPT40HB \square \star 25-01-A18					
ZPT40HB \square \star 50-01-A18	40	41.4	28.3	42.3	20.5
ZPT40HB \square \star 75-01-A18					
ZPT50HB \square \star 25-01-A18					
ZPT50HB \square \star 50-01-A18	50	52	36.2	52.7	24
ZPT50HB \square \star 75-01-A18					
Model	F	G	H	Y	
ZPT40HB \square \star 25-01-A18		72	127.5		
ZPT40HB \square \star 50-01-A18	32	107	162.5	13	
ZPT40HB \square \star 75-01-A18		143	198.5		
ZPT50HB \square \star 25-01-A18		75.5	131		
ZPT50HB \square \star 50-01-A18	35.5	110.5	166	16.5	
ZPT50HB \square \star 75-01-A18		146.5	202		

ZPT₈₀⁶³HB \square \star \blacksquare \square 01-A18

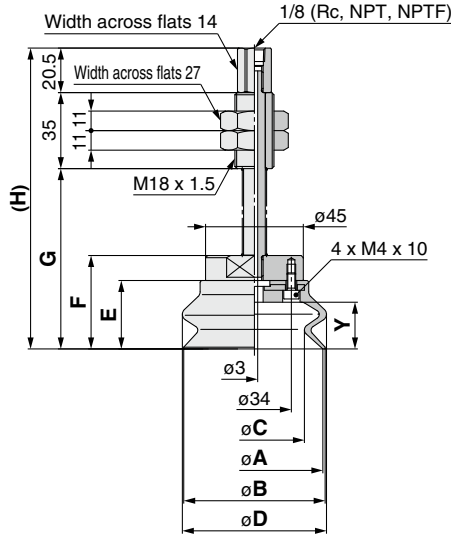

Dimensions

Model	A	B	C	D	E
ZPT63HB \square \star 25-01-A18					
ZPT63HB \square \star 50-01-A18	63	65.1	46	66.4	31.5
ZPT63HB \square \star 75-01-A18					
ZPT80HB \square \star 25-01-A18					
ZPT80HB \square \star 50-01-A18	80	82.8	60.1	83.8	37
ZPT80HB \square \star 75-01-A18					
Model	F	G	H	Y	
ZPT63HB \square \star 25-01-A18		83	138.5		
ZPT63HB \square \star 50-01-A18	43	118	173.5	21.5	
ZPT63HB \square \star 75-01-A18		154	209.5		
ZPT80HB \square \star 25-01-A18		88.5	144		
ZPT80HB \square \star 50-01-A18	48.5	123.5	179	27.5	
ZPT80HB \square \star 75-01-A18		159.5	215		

ZPT₁₂₅¹⁰⁰HB \square \star \blacksquare \square 01-A22

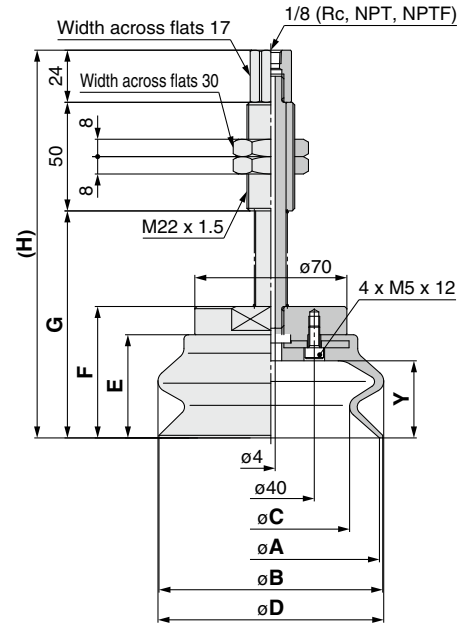

Dimensions

Model	A	B	C	D	E
ZPT100HB \square \star 25-01-A22					
ZPT100HB \square \star 50-01-A22	100	103	72.5	103.9	47.5
ZPT100HB \square \star 75-01-A22					
ZPT100HB \square \star 100-01-A22					
ZPT125HB \square \star 25-01-A22					
ZPT125HB \square \star 50-01-A22	125	128.5	92.2	131.6	56
ZPT125HB \square \star 75-01-A22					
ZPT125HB \square \star 100-01-A22					
Model	F	G	H	Y	
ZPT100HB \square \star 25-01-A22		104.5	178.5		
ZPT100HB \square \star 50-01-A22	60.5	140.5	214.5	35.5	
ZPT100HB \square \star 75-01-A22		180.5	254.5		
ZPT100HB \square \star 100-01-A22		215.5	289.5		
ZPT125HB \square \star 25-01-A22		113	187		
ZPT125HB \square \star 50-01-A22	69	149	223	44	
ZPT125HB \square \star 75-01-A22		189	263		
ZPT125HB \square \star 100-01-A22		224	298		

High Rigidity Pad **ZP Series**

How to Order

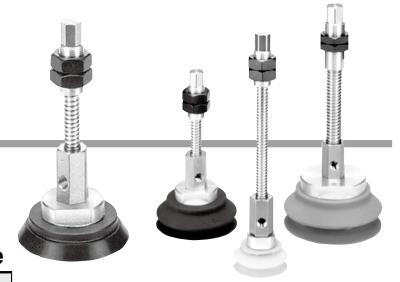

Vacuum inlet direction **Lateral**

With buffer **ZPX 40 H N J 25 - B01 - A18**

Pad diameter

Symbol	Pad diameter
40	ø40
50	ø50
63	ø63
80	ø80
100	ø100
125	ø125

Pad form (*)

Symbol	Form
H	High rigidity (Flat type with ribs)
HB	High rigidity (Bellows type)

Vacuum inlet thread size

Symbol	Thread size
B01	Rc1/8
N01	NPT1/8
T01	NPTF1/8

Mounting thread size

Symbol	Thread size
A18	M18 x 1.5 (ø40 to ø80)
A22	M22 x 1.5 (ø100, ø125)

Buffer stroke (■)

Stroke	ø40	ø50	ø63	ø80	ø100	ø125
25	●	●	●	●	●	●
50	●	●	●	●	●	●
75	●	●	●	●	●	●
100	—	—	—	—	●	●

Buffer body material (★)

Symbol	Material
J	Aluminum alloy
JB	Brass + With bushing
JF	Structural steel + With bushing

Pad material (□)

Symbol	Material
N	NBR
S	Silicone rubber*1*2
U	Urethane rubber
F	FKM
E	EPDM

*1 Compliant with the FDA (USA Food and Drug Administration) regulation 21CFR§177.2600 for "Rubber articles intended for repeated use"

*2 Compliant with the standards for "Rubber apparatus (excluding baby drinking apparatus) and containers/packaging" (D3) (Partial revision: Ministry of Health, Labour, and Welfare Notification No. 595, 2012) in Section 3 "Apparatus and Containers/Packaging" of the Food Sanitation Act, Article 18 "Specifications and Standards for Food and Food Additives, etc." (Ministry of Health and Welfare Notification No. 370, 1959).

Buffer Specifications (Rotating)

Pad diameter		ø40 to ø80	ø100, ø125
Stroke [mm]	At 0 stroke	25, 50, 75	25, 50, 75, 100
Spring reactive force [N]	At full stroke	6.9	10
		11.8	15

Nut Tightening Torque

[N·m]

Mounting thread size	Buffer body material		
	Aluminum alloy	Brass + With bushing	Structural steel + With bushing
M18 x 1.5	9.5 to 10.5	28 to 32	48 to 52
M22 x 1.5	9.5 to 10.5	45 to 50	75 to 80

Replacement Part Nos.

Model	Pad unit part no.	Buffer assembly part no.	
ZPX40*□★25-(B/N/T)01-A18	ZP40*□	ZPB-X1★25-(B/N/T)01	With three M3 bolts
ZPX40*□★50-(B/N/T)01-A18		ZPB-X1★50-(B/N/T)01	
ZPX40*□★75-(B/N/T)01-A18		ZPB-X1★75-(B/N/T)01	
ZPX50*□★25-(B/N/T)01-A18	ZP50*□	ZPB-X1★25-(B/N/T)01	With four M4 bolts
ZPX50*□★50-(B/N/T)01-A18		ZPB-X1★50-(B/N/T)01	
ZPX50*□★75-(B/N/T)01-A18		ZPB-X1★75-(B/N/T)01	
ZPX63*□★25-(B/N/T)01-A18	ZP63*□	ZPB-X2★25-(B/N/T)01	With four M4 bolts
ZPX63*□★50-(B/N/T)01-A18		ZPB-X2★50-(B/N/T)01	
ZPX63*□★75-(B/N/T)01-A18		ZPB-X2★75-(B/N/T)01	
ZPX80*□★25-(B/N/T)01-A18	ZP80*□	ZPB-X2★25-(B/N/T)01	With four M5 bolts
ZPX80*□★50-(B/N/T)01-A18		ZPB-X2★50-(B/N/T)01	
ZPX80*□★75-(B/N/T)01-A18		ZPB-X2★75-(B/N/T)01	
ZPX100*□★25-(B/N/T)01-A22	ZP100*□	ZPB-X3★25-(B/N/T)01	With four M5 bolts
ZPX100*□★50-(B/N/T)01-A22		ZPB-X3★50-(B/N/T)01	
ZPX100*□★75-(B/N/T)01-A22		ZPB-X3★75-(B/N/T)01	
ZPX100*□★100-(B/N/T)01-A22	ZP100*□	ZPB-X3★100-(B/N/T)01	With four M5 bolts
ZPX125*□★25-(B/N/T)01-A22		ZPB-X3★25-(B/N/T)01	
ZPX125*□★50-(B/N/T)01-A22		ZPB-X3★50-(B/N/T)01	
ZPX125*□★75-(B/N/T)01-A22	ZP125*□	ZPB-X3★75-(B/N/T)01	With four M5 bolts
ZPX125*□★100-(B/N/T)01-A22		ZPB-X3★100-(B/N/T)01	

* * in the table indicates the pad form

* □ in the table indicates the pad material

* ★ in the table indicates the buffer body material

Dimensions: With Buffer

ZPX₄₀⁴⁰H□★■-□01-A18

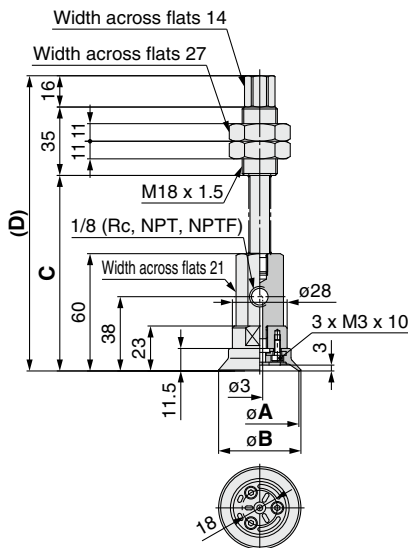

Dimensions

Model	A	B	C	D
ZPX40H□★25-□01-A18			100	151
ZPX40H□★50-□01-A18	40	42.1	135	186
ZPX40H□★75-□01-A18			171	222
ZPX50H□★25-□01-A18			100	151
ZPX50H□★50-□01-A18	50	52.1	135	186
ZPX50H□★75-□01-A18			171	222

ZPX₆₃⁶³H□★■-□01-A18

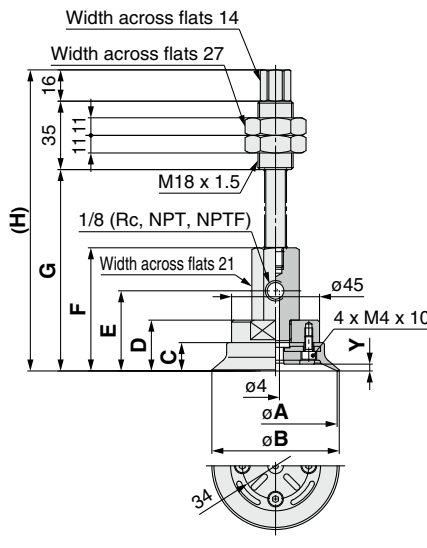

Dimensions

Model	A	B	C	D	E	F	G	H	Y
ZPX63H□★25-□01-A18			14.5	26	41	63	103	154	
ZPX63H□★50-□01-A18	63	65.2	14.5	26	41	63	138	189	3.5
ZPX63H□★75-□01-A18			14.5	26	41	63	174	225	
ZPX80H□★25-□01-A18			16.5	28	43	65	105	156	
ZPX80H□★50-□01-A18	80	82.1	16.5	28	43	65	140	191	4.5
ZPX80H□★75-□01-A18			16.5	28	43	65	176	227	

ZPX₁₀₀¹⁰⁰H□★■-□01-A22

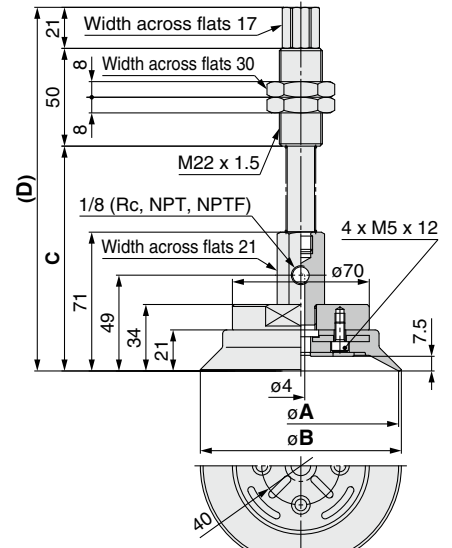

Dimensions

Model	A	B	C	D
ZPX100H□★25-□01-A22			115	186
ZPX100H□★50-□01-A22	100	102.8	151	222
ZPX100H□★75-□01-A22			191	262
ZPX125H□★25-□01-A22			226	297
ZPX125H□★50-□01-A22	125	127.7	115	186
ZPX125H□★75-□01-A22			151	222
ZPX125H□★100-□01-A22			191	262
ZPX125H□★100-□01-A22			226	297

Dimensions: With Buffer

ZPX₅₀⁴⁰HB□★■-□01-A18

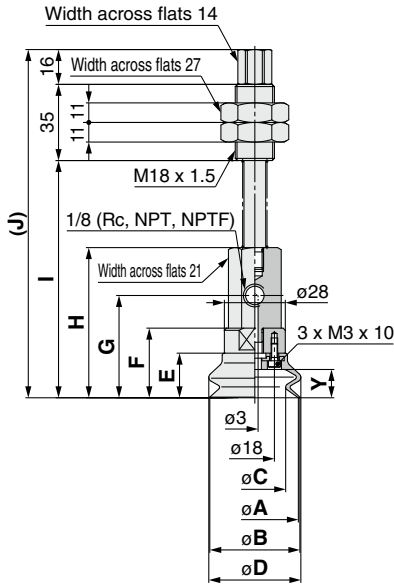

ZPX₈₀⁶³HB□★■-□01-A18

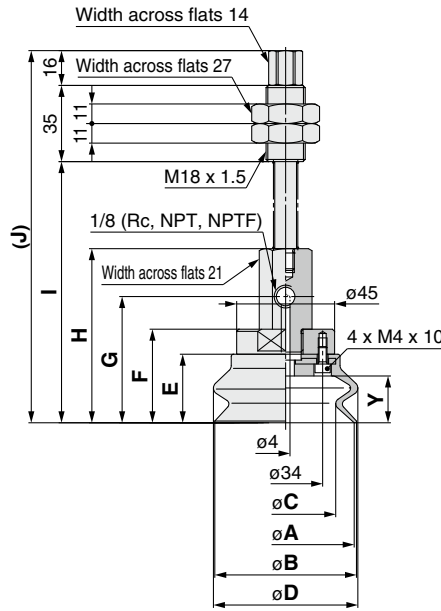

ZPX₁₂₅¹⁰⁰HB□★■-□01-A22

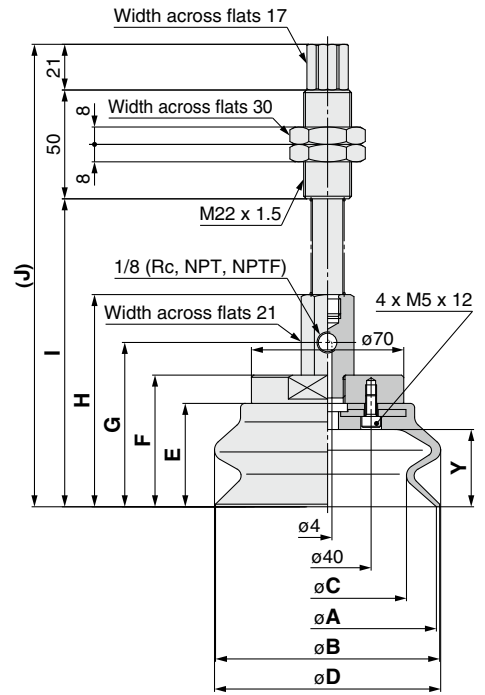

Dimensions

Model	A	B	C	D	E	F
ZPX40HB□★25-□01-A18						
ZPX40HB□★50-□01-A18	40	41.4	28.3	42.3	20.5	32
ZPX40HB□★75-□01-A18						
ZPX50HB□★25-□01-A18						
ZPX50HB□★50-□01-A18	50	52	36.2	52.7	24	35.5
ZPX50HB□★75-□01-A18						

Model	G	H	I	J	Y
ZPX40HB□★25-□01-A18			109	160	
ZPX40HB□★50-□01-A18	47	69	144	195	13
ZPX40HB□★75-□01-A18			180	231	
ZPX50HB□★25-□01-A18			112.5	163.5	
ZPX50HB□★50-□01-A18	50.5	72.5	147.5	198.5	16.5
ZPX50HB□★75-□01-A18			183.5	234.5	

Dimensions

Model	A	B	C	D	E	F
ZPX63HB□★25-□01-A18						
ZPX63HB□★50-□01-A18	63	65.1	46	66.4	31.5	43
ZPX63HB□★75-□01-A18						
ZPX80HB□★25-□01-A18						
ZPX80HB□★50-□01-A18	80	82.8	60.1	83.8	37	48.5
ZPX80HB□★75-□01-A18						

Model	G	H	I	J	Y
ZPX63HB□★25-□01-A18			120	171	
ZPX63HB□★50-□01-A18	58	80	155	206	21.5
ZPX63HB□★75-□01-A18			191	242	
ZPX80HB□★25-□01-A18			125.5	176.5	
ZPX80HB□★50-□01-A18	63.5	85.5	160.5	211.5	27.5
ZPX80HB□★75-□01-A18			196.5	247.5	

Dimensions

Model	A	B	C	D	E	F
ZPX100HB□★25-□01-A22						
ZPX100HB□★50-□01-A22	100	103	72.5	103.9	47.5	60.5
ZPX100HB□★75-□01-A22						
ZPX100HB□★100-□01-A22						
ZPX125HB□★25-□01-A22						
ZPX125HB□★50-□01-A22	125	128.5	92.2	131.6	56	69
ZPX125HB□★75-□01-A22						
ZPX125HB□★100-□01-A22						

Model	G	H	I	J	Y
ZPX100HB□★25-□01-A22			141.5	212.5	
ZPX100HB□★50-□01-A22	75.5	97.5	177.5	248.5	35.5
ZPX100HB□★75-□01-A22			217.5	288.5	
ZPX100HB□★100-□01-A22			252.5	323.5	
ZPX125HB□★25-□01-A22			150	221	
ZPX125HB□★50-□01-A22	84	106	186	257	44
ZPX125HB□★75-□01-A22			226	297	
ZPX125HB□★100-□01-A22			261	332	

Made to Order

ZP2V

XT661

MHM

Precautions



Made to Order Specific Product Precautions

Be sure to read this before handling the products.

Refer to page 375 for safety instructions. For vacuum equipment and vacuum pad precautions, refer to pages 376 to 379.

Mounting

1. Tighten the screw within the specified torque range when mounting the buffer.

Tightening with a torque outside of the specified range may cause malfunction.

ZP High Rigidity Series

Model	Connection thread	Buffer body material	Tightening torque [N·m]
ZP□(40 to 80)□J□-□-□	M18 x 1.5	Aluminum alloy	9.5 to 10.5
ZP□(40 to 80)□JB□-□-□		Brass	28 to 32
ZP□(40 to 80)□JF□-□-□		Structural steel	48 to 52
ZP□(100/125)□J□-□-□	M22 x 1.5	Aluminum alloy	9.5 to 10.5
ZP□(100/125)□JB□-□-□		Brass	45 to 50
ZP□(100/125)□JF□-□-□		Structural steel	75 to 80

ZP2 High Rigidity Ball Joint Series

Model	Connection thread	Buffer body material	Tightening torque [N·m]
ZP2-□(40/50)□JB□	M18 x 1.5	Brass	28 to 32
ZP2-□(40/50)□JF□		Structural steel	48 to 52
ZP2-□(63 to 125)□JF□-□-□	M22 x 1.5	Brass	45 to 50
ZP2-□(63 to 125)□JF□-□-□		Structural steel	75 to 80

Pad Mounting

1. How to mount the ZP/ZP2 high rigidity pad

Remove bolts with a hex key wrench from the pad underside. Tighten the new pad with the bolts ensuring there is no gap between the adapter plate and the pad.

Tightening Torque for Replacement of High Rigidity Pads

Pad diameter	Connection thread	Tightening torque [N·m]
ø40, ø50	M3 x 8	0.7 to 0.9
ø63, ø80	M4 x 8	0.9 to 1.1
ø100, ø125	M5 x 10	2.3 to 2.7

