

Heavy Duty Stopper Cylinder

RSH Series

ø20, ø32

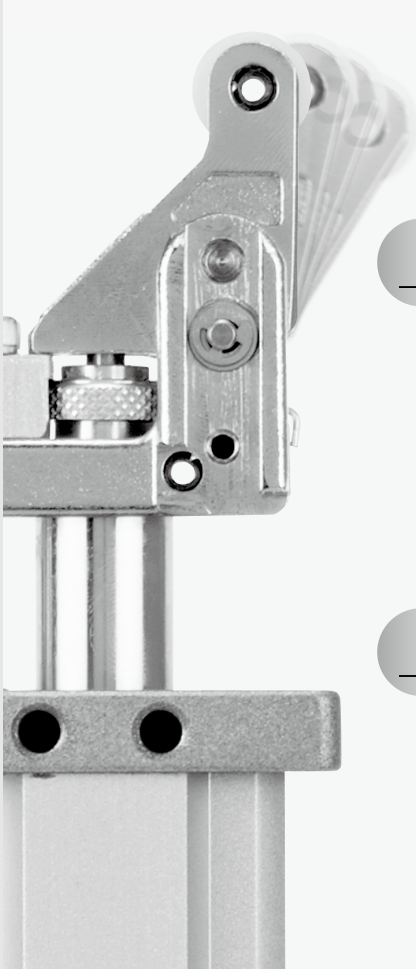

To stop pallets gently Stopper cylinder with built-in shock absorber

Amount of energy absorption can be adjusted to suit the load.

Stops the workpiece gently with built-in shock absorber.

The retardation value can be changed by rotating the adjustment dial.

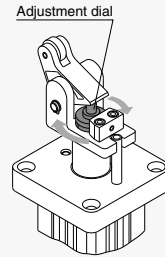

Easy replacement of shock absorbers

The shock absorber can be removed by just detaching the stopper and adjustment dial. This ensures easy maintenance.

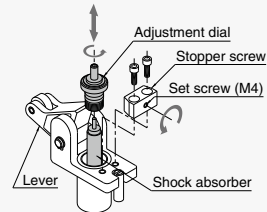

Series Variations

Series	Bore size (mm)	Standard stroke (mm)		Mounting type	Actuation system	Rod end shape	Standard variations		Options		
		15	20				Built-in magnet	With lock mechanism	With cancel	With proximity sensor	
RSH	20	●		Flange	Double acting	Lever	●	●	●	●	
	32	●					Double acting spring type	●	●	●	●
					Single acting retraction type	Adjustable	●	●	●	●	

RSQ

RSG

RS2H

RSH

MIW

MIS

D-□

-X□

The roller lever direction can be changed in 90° steps.

The roller lever of the stopper can be rotated 360° in 90° increments for ø32 (180° for ø20) to adapt it to the direction of the workpiece.

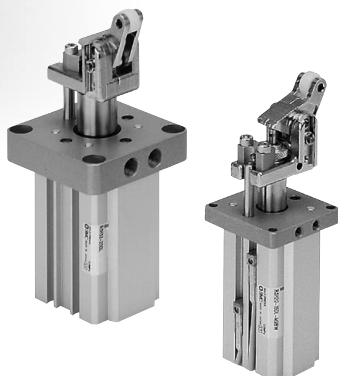
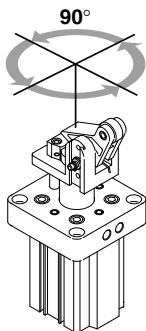
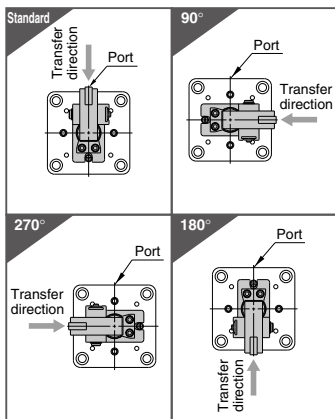

Side piping (flange) is possible.

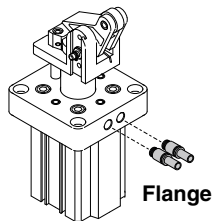

Options

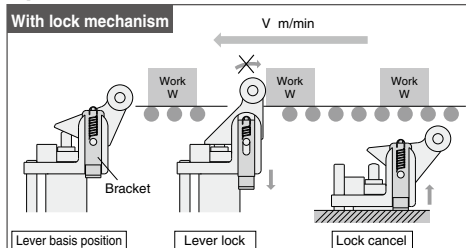

The lever lock mechanism prevents even lightweight pallets from rebounding off the shock absorber's spring.

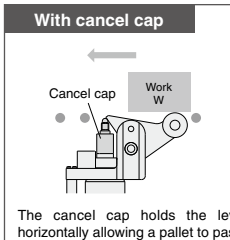

The cancel cap holds the lever horizontally allowing a pallet to pass.

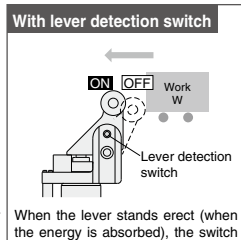

When the lever stands erect (when the energy is absorbed), the switch turns on a signal that determines the pallet has reached the stop position. (For more information, please refer to page 615.)

High power rod

Bore size (mm)	20	32
Rod size (mm)	14	20

3 types of operation

1. Single acting
2. Double acting
3. With double acting spring

Auto switch mounting available

Auto switches can be mounted without protruding from the body surface.

2 types of roller materials are available depending on the application. (Resin, Carbon steel)

RSH Series Model Selection

Operating Range

(Example) Weight of transferred object 10 kg, Transfer speed 10 m/min, Friction coefficient $\mu = 0.1$

(How to read graph)

In graph [2], find the intersection of the vertical axis representing the weight of transferred object of 10 kg and the horizontal axis representing the transfer speed of 10 m/min. And select the bore size $\phi 20$ positioned within the operating range of the cylinder.

Graph ①

$\mu = 0$

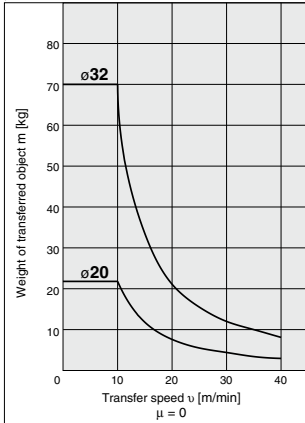

Graph ②

$\mu = 0.1$

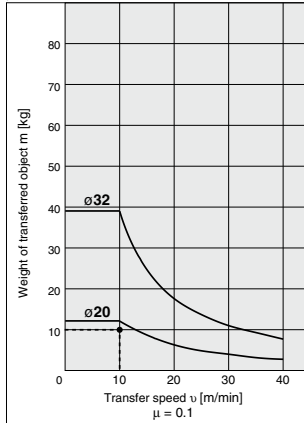

* The graphs for the load mass and transfer speed show the values measured at room temperature (20 to 25°C).

Lateral Load and Operating Pressure

The greater lateral load needs higher cylinder operating pressure. Set the operating pressure by using the graph as a guideline.

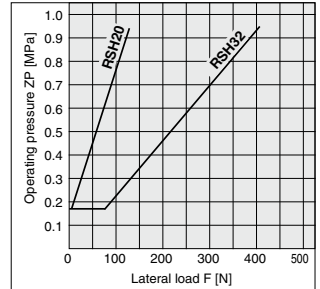

RSQ

RSG

RS2H

RSH

MIW
MIS

D-

-X

Heavy Duty Stopper Cylinder

RSH Series

ø20, ø32

How to Order

RSH **32** - **20** **D** **L** - **M9BW**

Bore size

20	20 mm
32	32 mm

Port thread type

Nil	M*
	Rc
TN	NPT
TF	G

* The tube I.D. of 20 is only available to port size M screws.

Cylinder stroke

15	15mm (RSH20)
20	20mm (RSH32)

Action

D	Double acting type
B	Double acting spring type
T	Single acting/Spring extended

Roller material

L	Resin
M	Carbon steel

Number of auto switches (Auto switch number mounted)

Nil	2 pcs.
S	1 pc.

Auto switch

Nil	Without auto switch (Built-in magnet)
-----	---------------------------------------

* Refer to the table below for auto switch model numbers.

Option (Note 1)

Nil	Without option
D	With lock mechanism
C	With cancel cap
S (Note 2)	With lever detection switch

Note 1) Options can be combined. Indicate the symbols, according to the priority order of D.C.S.

Note 2) Lever detection switch type

Type	E2E-S05S12-WC-C1 2M
------	---------------------

* Manufactured by OMRON Corporation.

Applicable auto switches/Refer to pages 941 to 1067 for detailed auto switch specifications.

Type	Special function	Electrical entry	Indicator light	Wiring (output)	Load voltage		Auto switch models		Lead wire length (m)			Pre-wired connector	Applicable load		
					DC	AC	Perpendicular	In-line	0.5 (Nil)	1 (M)	3 (L)		5 (Z)	IC circuit	Relay, PLC
Solid state auto switch	—	Grommet	Yes	3-wire (NPN)	24 V	5 V, 12 V	—	M9NV	M9N	●	●	○	○	IC circuit	Relay, PLC
				3-wire (PNP)				M9PV	M9P	●	●	○	○		
				2-wire				M9BV	M9B	●	●	○	○		
	Diagnostic indication (2-color display)			3-wire (NPN)	M9NWV	M9NW	●	●	○	○	IC circuit	Relay, PLC			
				3-wire (PNP)	M9PWV	M9PW	●	●	○	○	IC circuit				
				2-wire	M9BWW	M9BW	●	●	○	○	—				
Water resistance (2-color display)	3-wire (NPN)	M9NAV**	M9NA**	○	○	●	○	IC circuit	Relay, PLC						
	3-wire (PNP)	M9PAV**	M9PA**	○	○	●	○	IC circuit							
	2-wire	M9BAV**	M9BA**	○	○	●	○	—							
Reed auto switch	—	Grommet	Yes	3-wire (NPN equiv)	—	5 V	—	—	Z76	●	—	—	—	IC circuit	—
				No	2-wire	24 V	12 V	100 V	—	Z73	●	—	—	—	—
							100 V or less	—	Z80	●	●	—	—	IC circuit	—

** Water resistant type auto switches can be mounted on the above models, but in such case SMC cannot guarantee water resistance. Consult with SMC regarding water resistant types with the above model numbers.

* Lead wire length symbols: 0.5 m Nil (Example) M9NW
 1 m M (Example) M9NWM
 3 m L (Example) M9NWL
 5 m Z (Example) M9NWX

* Solid state auto switches marked with a "○" symbol are produced upon receipt of order.
 * D-A9□/A9□V types cannot be mounted.

* Refer to page 614 since there are applicable auto switches other than listed.
 * Refer to pages 1014 and 1015 for the details of auto switches with a pre-wired connector.
 * Auto switches are shipped together (not assembled).



Specifications

		RSH	
Bore size (mm)		20	32
Action	Double acting, Double acting spring, Single acting (Spring extended)		
Type of rod end	Lever with built-in shock absorber type		
Fluid	Air		
Proof pressure	1.5 MPa		
Max. operating pressure	1.0 MPa		
Ambient and fluid temperature	-10 to 60°C (No freezing)		
Lubrication	Not required (non-lube)		
Cushion	Rubber bumper		
Stroke length tolerance	+1.4 0		
Mounting	Flange		
Port size Rc, NPT, G	M5 x 0.8	1/8	
	—	1/8	
	—	1/8	

Bore Size, Standard Stroke

(mm)

Model	Bore size (mm)	Standard stroke
RSH	20	15
	32	20

Weight

(kg)

Action	Rod end configuration	Bore size (mm)	Weight
Double acting type Double acting spring type Single acting spring extended	Lever with built-in shock absorber type	20	0.41
		32	0.75

RSQ

RSG

RS2H

RSH

MIW
MIS

D-□

-X□

RSH Series

Construction

ø20, ø32

Double acting (DL, DM)

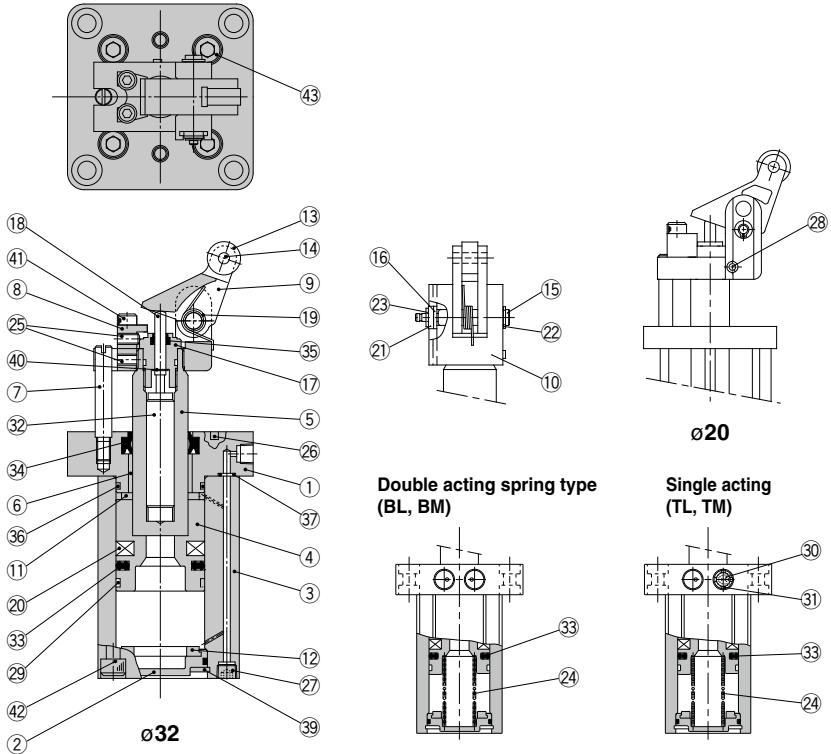

Options (With lock mechanism, with cancel cap)

With lock mechanism (-D)

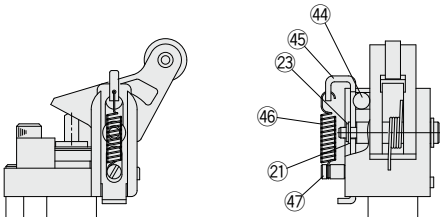

With cancel cap (-C)

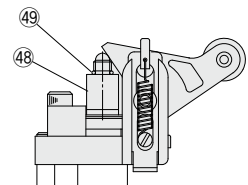

Parts List

No.	Description	Material	Note
1	Rod cover	Aluminum alloy	Metallic painted
2	Bottom plate	Aluminum alloy	Chromate
3	Cylinder tube	Aluminum alloy	Hard anodized
4	Piston	Aluminum alloy	Chromate
5	Piston rod	ø20: Stainless steel ø32: Carbon steel	Hard chrome plated
6	Bushing	Bearing alloy	
7	Guide rod	Carbon steel	Hard chrome plated
8	Stopper screw	Stainless steel	
9	Lever	Carbon steel	Nickel plated
10	Lever holder	Carbon steel	Nickel plated
11	Bumper A	Urethane	
12	Bumper B	Urethane	
13	Roller	Resin Carbon steel	-□□L -□□M
14	Spring pin	Carbon tool steel	
15	Lever pin	Carbon steel	
16	Ring A	Rolled steel	Nickel plated
17	Adjustment dial	Aluminum alloy	
18	End rod	Special steel	
19	Lever spring	Steel wire	
20	Magnet	—	
21	Flat washer	Steel wire	Nickel plated
22	Type C retaining ring for shaft	Carbon tool steel	
23	Type E retaining ring for shaft	Carbon tool steel	
24	Return spring	Steel wire	-T□/-B□
25	Hexagon socket head set screw	Chrome molybdenum steel	
26	Parallel pin	Carbon steel	ø20 only
27	Hexagon socket head plug	Chrome molybdenum steel	Nickel plated
28	Spring pin	Carbon tool steel	ø20 only
29	Wear ring	Resin	
30	Element	Bronze	-T□ only (ø20 is socket set screw)
31	Retaining ring	Carbon tool steel	ø32 -T□ only
32	Shock absorber	—	
33	Piston seal	NBR	
34	Rod seal	NBR	
35	Scraper	NBR	
36	Tube gasket	NBR	
37	O-ring	NBR	
38	Bottom plate gasket	NBR	
39	Type C retaining ring for hole	Carbon tool steel	Phosphate coated
40	Type CE retaining ring for shaft	Carbon tool steel	Phosphate coated
41	Hexagon socket head cap screw	Chrome molybdenum steel	Zinc chromated
42	Hexagon socket head cap screw	Stainless steel	ø20 only
43	Hexagon socket head cap screw	Stainless steel	ø32 only
44	Steel balls	Carbon steel	
45	Bracket	Carbon steel	Chromate
46	Bracket spring	Stainless steel wire	
47	Pin E	Stainless steel	
48	Cancel cap	Aluminum alloy	Clear anodized
49	O-ring	NBR	

Replacement Parts/ Seal Kit

Bore size (mm)	Kit no.		Contents
	Double acting	Single acting	
20	RSH20D-PS	RSH20T-PS	Set of items 33 to 37 in above table (excluding 34)
32	RSH32D-PS	RSH32T-PS	

*Seal kit includes 33 to 37 (excluding 34). Order the seal kit based on each bore size.

*Since the seal kit does not include a grease pack, order it separately.

Grease pack part no.: GR-S-010 (10 g)

Replacement Parts/ Shock Absorber

Bore size (mm)	Order no.
20	RSH-R20
32	RSH-R32

RSQ

RSG

RS2H

RSH

MIW
MIS

D-□

-X□

RSH Series

Dimensions/Bore size: $\text{\O}20$

RSH20-15□□

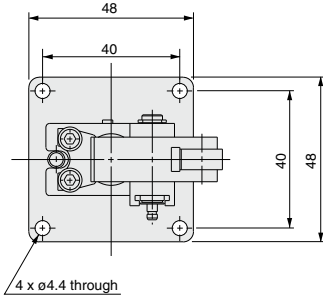

*The figure shows an extended piston rod.

Load carrying direction

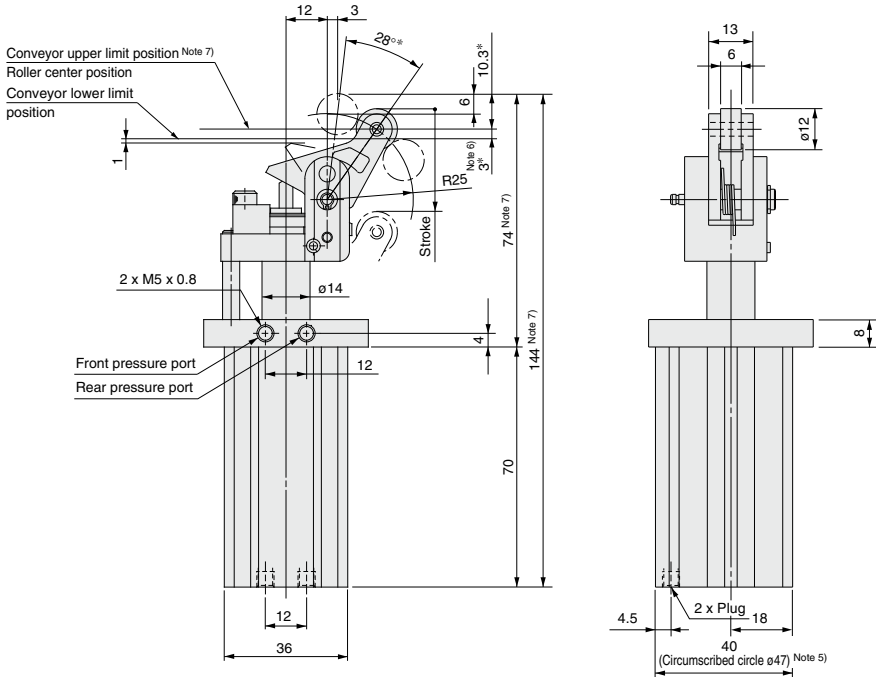

Note 1) The figure shows dimensions at the maximum energy absorption capacity.

Note 2) Dimensions with auto switch are identical to the above.

Note 3) The figure shows an extended piston rod.

Note 4) The dimensions marked with "°" vary according to adjustment of the shock absorber dial.

Note 5) Circumscriber circle $\text{\O}47$ means that diameter of the circle circumscribed to the cylinder angles. Mounting hole diameter must be $\text{\O}48$. Be careful of the interference between the lever and the mounting base when mounted from the lever side. Thus, the thickness of the mounting base must be 8 mm or less.

Note 6) It is recommended to set the conveyor height in a range from the lower limit position to the upper limit position of the conveyor (dimension *3 shown in the figure).

Note 7) The dimensions in the figure do not include the stroke length tolerance (0 to +1.4 mm). When fixing the cylinder (setting the conveyor position), take this into consideration, and be sure to set the cylinder within the range of Note 6) using the upper limit position of the conveyor (roller center position) as a reference.

Dimensions/Bore size: $\varnothing 32$

RSH32-20□□

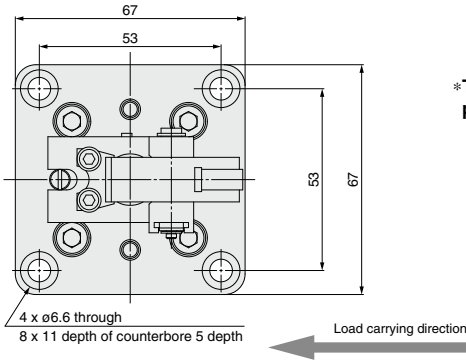

*The figure shows an extended piston rod.

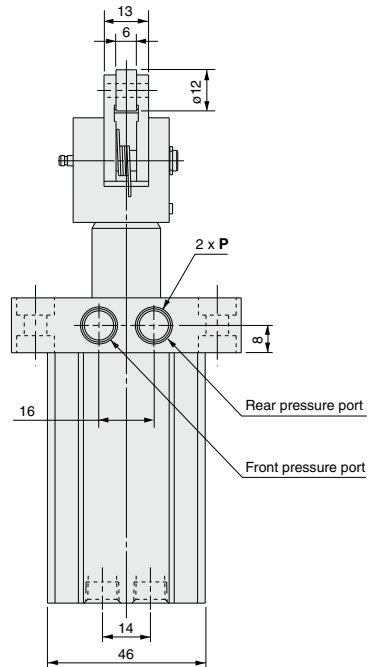
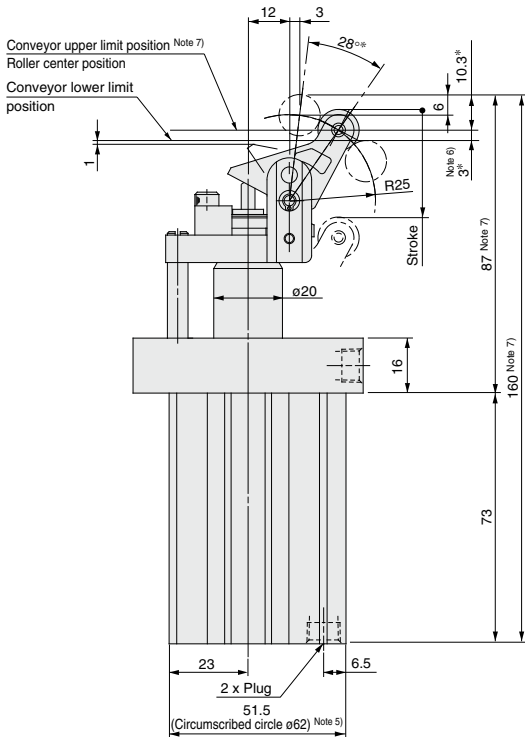

Note 1) The figure shows dimensions at the maximum energy absorption capacity.

Note 2) Dimensions with auto switch are identical to the above.

Note 3) The figure shows an extended piston rod.

Note 4) The dimensions marked with "*" vary according to adjustment of the shock absorber dial.

Note 5) Circumscribed circle $\varnothing 62$ means that diameter of the circle circumscribed to the cylinder angles. Mounting hole diameter must be $\varnothing 63$. Be careful of the interference between the lever and the mounting base when mounted from the lever side. Thus, the thickness of the mounting base must be 9 mm or less.

Note 6) It is recommended to set the conveyor height in a range from the lower limit position to the upper limit position of the conveyor (dimension "3" shown in the figure).

Note 7) The dimensions in the figure do not include the stroke length tolerance (0 to +1.4 mm). When fixing the cylinder (setting the conveyor position), take this into consideration, and be sure to set the cylinder within the range of Note 6) using the upper limit position of the conveyor (roller center position) as a reference.

P (Piping port)		
Nil	TN	TF
Rc 1/8	NPT 1/8	G 1/8

RSQ

RSG

RS2H

RSH

MIW

MIS

D-□

-X□

Auto Switch Mounting

Auto Switch Proper Mounting Position (Detection at Stroke End)

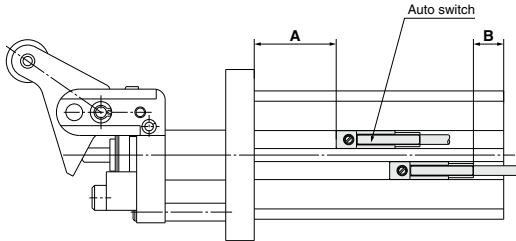

Auto switch proper mounting position

(mm)

Auto switch models	D-M9□ D-M9□W D-M9□AV		D-M9□V D-M9□WV		D-M9□A		D-Z7□/Z80 D-Y59□/Y7P/Y7□W		D-Y69□/Y7PV D-Y7□WV		D-Y7BA	
	A	B	A	B	A	B	A	B	A	B	A	B
Bore size 20	23	8.5	23	10.5	23	6.5	18	8(6.5)	18	9.5	18	2
32	18.5	11	18.5	13	18.5	9	13.5	10.5(9)	13.5	12	13.5	4.5

The values inside () are for D-Z73.

Note) Adjust the auto switch after confirming the operating conditions in the actual setting.

Operating Range

(mm)

Auto switch models	Bore size	
	20	32
D-M9□/M9□V D-M9□W/M9□WV D-M9□A/M9□AV	5.5	6.0
D-Z7□/Z80	8	10
D-Y59□/Y69□ D-Y7P/Y7PV D-Y7□W/Y7□WV D-Y7BA	5	3.5

*Since the operating range is provided as a guideline including hysteresis, it cannot be guaranteed (assuming approximately ±30% dispersion). It may vary substantially depending on an ambient environment.

Auto Switch Mounting Bracket/Part No.

Auto switch models	Bore size (mm)	
	ø20, ø32	
D-M9□/M9□V D-M9□W/M9□WV D-M9□A/M9□AV	BMG2-012	

D-M9□(V)/M9□W(V)/M9□A(V)

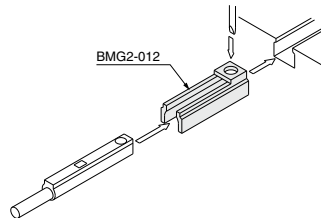

Besides the models listed in How to Order, the following auto switches are applicable.
Refer to pages 941 to 1067 for detailed specifications.

Auto switch type	Model	Electrical entry	Features
Solid state	D-Y69A, Y69B, Y7PV	Grommet (Parpendicular)	-
	D-Y7NWV, Y7PWV, Y7BWV		Diagnostic indication (2-color display)
	D-Y59A, Y59B, Y7P	Grommet (In-line)	-
	D-Y7NW, Y7PW, Y7BW		Diagnostic indication (2-color display)
	D-Y7BA		Water resistance (2-color display)

*For solid state auto switches, auto switches with a pre-wired connector are also available. Refer to pages 1014 and 1015 for details.

*Normally closed (NC = b contact) solid state auto switches (D-F9G/F9H/Y7G/Y7H types) are also available. Refer to pages 959 and 961 for details.

RSH Series

Lever Detection Switch (Proximity Switch)

Proximity switch specifications/Maker: OMRON Co. Ltd.

Model	E2E-S05S12-WC-C1 2M
Wiring type	3-wire
Output system	NPN type
Output type	Normally open
Power supply voltage (Operating voltage range)	12 to 24 VDC (10 to 30 VDC), Ripple 10% or less (P-P)
Current consumption (Leakage current)	10 mA or less
Response frequency	4 kHz
Control output (chest)	Open collector maximum 100 mA
Indicator light	Detection indication (Yellow European Standard EN60947-5-2 compliant)
Ambient temperature	-25 to 70°C (No freezing)
Operating ambient humidity	35 to 95% RH
Residual voltage ^{Note 1)}	2 V or less
Withstand voltage ^{Note 2)}	500 VAC
Vibration	Endurance 10 to 55 Hz, Duplex amplitude 1.5 mm X,Y,Z direction each 2h
Impact	Endurance 500 m/s ² (approx. 50 G), X, Y, Z direction each 10 times
Enclosure	IEC standards IP67 (Immersion proof shape and oil proof shape by JEM standards IP67G)

Mounting Position

●E2E-S05S12-WC-C1 2M

While holding the lever in the detection range of the switch, screw in the switch gradually until the indicator light (red) turns on. Then, screw the switch in further, halfway between the turn-on point and the lever.

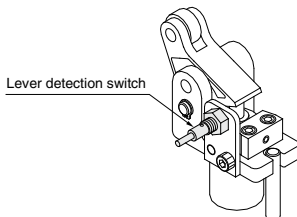

Note 1) At load current 100 mA and cord length of 2 m

Note 2) Between case and whole charging part

Dimensions

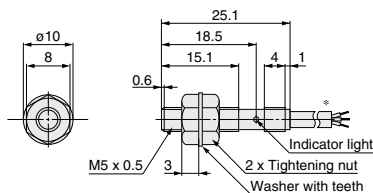

* Vinyl insulation round cord $\phi 2.9$, 3 cores,
(Conductor area: 0.14mm², Insulator O.D.: $\phi 0.8$) Standard 2 m

Output Circuit

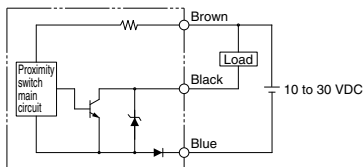

RSQ

RSG

RS2H

RSH

MIW
MIS

D-□

-X□



RSH Series

Specific Product Precautions

Be sure to read this before handling the products.

Refer to back page 50 for Safety Instructions and pages 3 to 12 for Actuator and Auto Switch Precautions.

Instructions

⚠ Caution

1. Shock absorber capacity variable adjustment method

To stop the workpiece gently, loosen the set screw (M4) on the stopper and turn the adjustment dial in response to the energy value of the workpiece so as to select an optimal absorbing position (resistive force value). Turning the adjustment dial clockwise will decrease the resistive force value while turning the adjustment dial counterclockwise will increase the resistive force value. After the dial has been adjusted correctly, tighten the set screw firmly to secure the adjustment dial.

• Set screw (M4) tightening torque: 1.5 N·m

Note 1) Cautions for adjustment When adjusting the shock absorber resistive force value, first try the maximum value and then proceed to smaller values. If the energy value of the transferred workpiece is larger than the resistive force value of the shock absorber, an excessive load will be applied to the lever and may cause damage.

Note 2) As the adjustment dial is turned, the stroke of the shock absorber is variably changed (4 st to 6 st) and the resistive force value of the shock absorber can be changed. As the stroke is changed, the lever angle is also changed.

Note 3) Please consult SMC if shock absorption is not soft, even after adjusting the shock absorber with the above method.

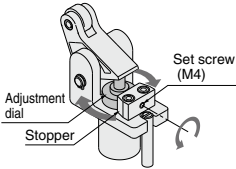

2. How to change the positional relationship between the transfer and piping directions

The positional relationship between the transfer and piping directions can be changed in 90° increments (or 180° increments in case of ø20).

Insert a flat blade screwdriver into the notch at the guide rod end to loosen the guide rod. The lever is then turned freely. For ø32 type, the lever can be changed in 90° steps. For ø20 type, the lever can be reversed 180°.

• Guide rod tightening torque

ø20: 1.5N·m

ø32: 3.0N·m

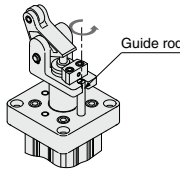

3. How to replace shock absorber during maintenance

Loosen the hexagon socket head cap screw on the stopper and the set screw (M4) that secures the shock absorber, and then remove the stopper from the lever holder. Incline the lever 90° and pull out the shock absorber after the adjustment dial has been removed.

*Cautions for assembly

After replacing the shock absorber, tighten the bolts and fixing screw firmly and apply grease to the shock absorber rod end surface.

• Tightening torque

Set screws (M4): Common to all sizes 1.5 N·m

Hexagon socket head cap screws (M4): Common to all sizes 1.5 N·m

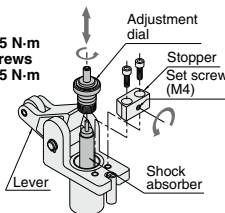

Selection

⚠ Danger

1. Use the equipment only within the specified operating range.

If the condition exceeds the specified operating range, it will cause excessive impact or vibration to the stopper cylinder, leading to possible damages.

⚠ Caution

1. Do not collide the pallet while the lever is standing erect.

In case of a lever with built-in shock absorber type, do not collide the next pallet while the lever is standing erect. Otherwise, all energy will be applied to the cylinder body.

2. When a load directly connected to the cylinder is stopped at an intermediate position:

Apply the operating range in the catalog only in these cases where the stopper cylinder is used to stop pallets on a conveyor belt. When using the stopper cylinder to stop loads directly connected to a cylinder or some other equipment, a lateral load is applied as the cylinder thrust. Consult SMC in such cases.

Mounting

⚠ Caution

1. Do not apply rotational torque to the cylinder rod.

Align the cylinder parallel to the working face of the pallet working when installing in order to prevent rotational torque working on the cylinder rod.

2. Do not scratch or gouge the sliding part of the piston rod or guide rod.

Scratches and gouges may damage the packing, causing air leakage or malfunction.

3. If the conveyor setting position is incorrect, the pallets or other items being conveyed may touch the lever (protrusion on the side of the shock absorber). When installing the cylinder, be very careful of the contents of Note 7) indicated in the dimensions.

Operation

⚠ Caution

1. In case of cylinders with locking mechanism, do not apply an external force from the opposite side when the lever is locked.

Lower the cylinder before adjusting the conveyor or moving the pallet.

2. In case of cylinders with locking mechanism, do not collide the pallet and roller when the lever is locked.

If the pallet collides with the roller in the locked state, it may cause lever malfunction. (The lever is released when the cylinder is fully retracted.)

3. Some structural backlash is present in the lever lock mechanism.

As the stopping position of the pallet can be affected by the weight of the object being transferred, the operating conditions of the conveyor, etc., the stopping position may vary. Please contact SMC if a higher level of stopping accuracy is required for the pallet.

4. Do not let your hand become caught when operating the cylinder.

The lever holder goes up and down while the cylinder is in operation. Pay sufficient attention not to let your hand or fingers become caught between the rod cover and lever holder.

5. Do not let water, cutting oil or dust splash on the equipment.

It can cause oil leakage and malfunction of the shock absorber.

6. The stop state of the workpiece may vary depending on changes in ambient temperature or secular changes in shock absorber resistive force.

Check the stop state periodically and adjust the shock absorber resistive force at appropriate intervals.