

## TK Helical Bevel Gear Motor



**CONTENTS**

Page

1	▶	SUMMARIZE
2-4	▶	PRODUCT STRUCTURE PICTURE
5	▶	MODEL ILLUMINATE
6 - 10	▶	RELEVANT PARAMETER
11	▶	SELECTION EXAMPLE
10 - 27	◀	GEAR UNIT SELECTION TABLES
	▶	Possible geometrical combinations
30 - 77	▶	TK..Performance parameter
78 - 87	▶	TK../TRF..Performance parameter
	◀	OUTLINE DIMENSION SHEET
88 - 131	▶	TK.. Outline dimension
132	▶	TK../TRF.. Outline dimension
133-134	▶	TK..AM(IEC) Outline dimension
135	▶	TK..AD Outline dimension
	◀	INSTALLATION
136	▶	Mounting positions designation
137-143	▶	Mounting positions
143	▶	Installation methods
	◀	LUBRICANTS
144	▶	Types of lubricants
145	▶	Lubricant fill quantity
145-146	▶	MAINTENANCE
146	▶	STORAGE
146	▶	NOTICE FOR ORDER
147	▶	MULFUNCTIONS
148-149	▶	CHARGE CHARACTERISTIC CHART
150	▶	SHOW THE SERIES PRODUCTS



## **1. SUMMARIZE**

**TK Series** helical-bevel gearmotor is a new generation mechanic-electrical integrated product, which designed basing on the modular system. It can be connected respectively with motors such as common motor, brake motor, explosion-proof motor, frequency conversion motor, servo motor, **IEC** motor and so on. It can be mounted discretionary six orientation in solid space. This kind of product is widely used in drive fields such as textile, foodstuff, beverage, chemical industry, automatic arm ladder, automatic storage equipment, metallurgy, tobacco, environment-protection, logistics and so on.

### **1.1 PERFORMANCE CHARACTERISTICS**

1. Transmission ratio with fine stage covers a wide range;
2. Compact structure takes up small room;
3. low vibration; low noise; low energy dissipation;
4. Deft design; reliable and wearable; wide usage;
5. Modular, multistructure, can be combined in many forms to meet needs of all kinds of transmission conditions.

**TK Series** helical-bevel gearmotor is formed of helical-bevel gears unit and motor. The helical gear and bevel gear use high quality alloy steel with surface hardening; which shoped by high precision device. All housing are in cast iron. offer precision finishing to ersure the shape and position precision, and it reaches advantageous performance such as: strong bearing capacity, long service-life; small volume; big ratio; light , high efficiency, low noise.

**TK Series** helical-bevel gearmotor has more than ten models. Combined with **TRF** series, the multi-stage gear reduction can be achieved. Power 0.12-200KW; Ratio 3.98-32625; Torque 200-50000Nm. It can connect (foot, flange) discretionary and use multi-mounting positions according to customers' requirements.



2. PRODUCT PICTURE



**TK..MY..**



**TKF..MY..**



**TKA..B MY..  
TKV..B MY..**



**TKH..B MY..**



**TKA..MY..  
TKV..MY..**



**TKH..MY..**



**TKAF..MY..  
TKVF..MY..**



**TKHF..MY..**



**TKAZ..MY..  
TKVZ..MY..**



**TKHZ..MY..**



**TK..AM(IEC)..**



**TK..AD..**

## 2.2 Designs

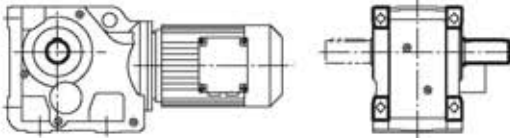

### TK..MY..

Foot-mounted helical-bevel geared motor

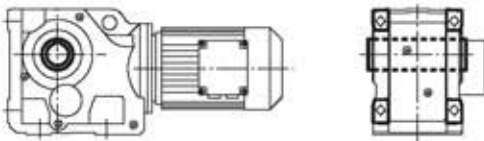

### TKA..B MY..

Foot-mounted helical-bevel geared motor with hollow shaft

### TKV..B MY..

Foot-mounted helical-bevel geared motor with splined hollow shaft to DIN 5480

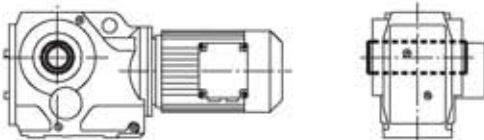

### TKA..MY..

Helical-bevel geared motor with hollow shaft

### TKV..MY..

Helical-bevel geared motor with splined hollow shaft to DIN 5480

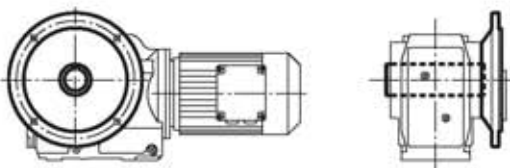

### TKAF..MY..

Helical-bevel geared motor in B5 flange-mounted version with hollow shaft

### TKVF..MY..

Helical-bevel geared motor in B5 flange-mounted version with splined hollow shaft to DIN 5480

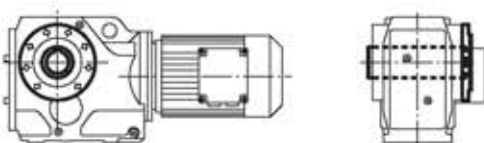

### TKAZ..MY..

Helical-bevel geared motor in B14 flange-mounted version with hollow shaft

### TKVZ..MY..

Helical-bevel geared motor in B14 flange-mounted version with splined hollow shaft to DIN 5480

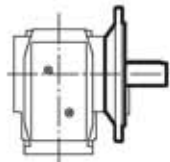
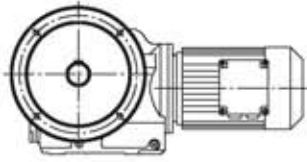

**TKF..MY..**

Helical-bevel geared motor in B5 flange-mounted version

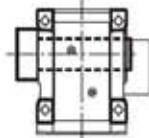
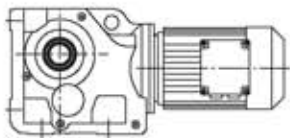

**TKH..B MY..**

Foot-mounted Helical-bevel geared motor with hollow shaft and shrink disk

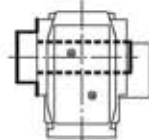
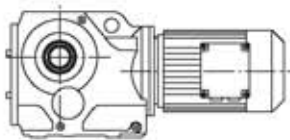

**TKH..MY..**

Helical-bevel geared motor with hollow shaft and shrink disk

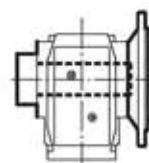
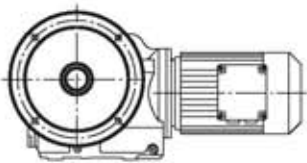

**TKHF..MY..**

Helical-bevel geared motor in B5 flange-mounted with hollow shaft and shrink disk

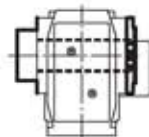
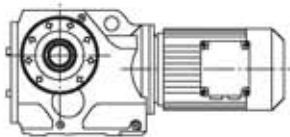

**TKHZ..MY..**

Helical-bevel geared motor in B14 flange-mounted with hollow shaft and shrink disk

## 3. MODEL ILLUMINATE

**TK A 88 B - MY 180 M 4 / BMG / HF / TF - 21.32 - M6 / 270 °**

① ② ③ ④ ⑤ ⑥ ⑦ ⑧ ⑨ ⑩ ⑪ ⑫ ⑬ ⑭

No	Comments
1	<b>TK:</b> code for gear units series
2	1). no code means foot-mounted 2). <b>A:</b> hollow shaft 3). <b>H:</b> hollow shaft with shrink disk 4). <b>V:</b> splined hollow shaft to DIN 5480 5). <b>F:</b> B5 flange-mounted 6). <b>Z:</b> B14 flange-mounted
3	specification code of gear units 38, 48... ..
4	1). <b>B:</b> foot-mounted 2). <b>/T:</b> torque arm-mounted
5	1). <b>MY:</b> motor code 2). <b>AM:</b> IEC input couplings
6	specification code of motor (high in motor centre )
7	length code of stator core <b>D, K, L, M, ML, N, S</b>
8	pole number of motor 2, 4, 6, 8
9	1). no code means no brake 2). <b>BMG:</b> brake
10	1). no code means no manual release device 2). <b>HF:</b> manual release device with self-locking function 3). <b>HR:</b> manual release device with outself-locking function
11	1). no code means no motor heat-protection device 2). <b>TF:</b> motor heat- protection device
12	transmission ratio of gear units <b>i</b>
13	<b>M1:</b> mounting positio, default mounting position <b>M1</b> not to write out is ok
14	Position diagram for motor terminal box default position <b>0<sub>o</sub>(R)</b> not to write out is ok

Example: **TK58 - MY63M4 - 108.29**  
**TKF68 - AM80 - 27.28**  
**TKAF88 - MY90S4 / BMG -115.82**



#### 4. RELEVANT PARAMETER

##### 4.1 Power $P$

$$P_1 = \frac{P_2}{\eta} \text{ [kW]}$$

$$P_{1n} \geq P_1 \cdot f_s \text{ [kW]}$$

- $P_1$  Input power
- $P_2$  Output power
- $P_{1n}$  Rated power driving motor
- $f_s$  Service factor
- $\eta$  Transmission efficiency

TK Series gear units transmission efficiency  $\eta = 94\%$

##### 4.2 Rotation speed

- $n_1$  Gear units input speed
- $n_2$  Gear units output speed

If driven by the external gearing, 1400r/min or lower rotation speed is suggested so as to optimize the working conditions and prolong the service life. Higher input rotation speed is permitted, but in this situation, the rated torque  $M_2$  will be reduced.

##### 4.3 Transmission ratio $i$

$$i = \frac{n_1}{n_2}$$

Usually transmission ratio is decimal fraction with 2 radix point tagged in selection tables.

##### 4.4 Torque $M$

$$M_2 = \frac{9550 \cdot P_1 \cdot \eta}{n_2} \text{ [Nm]}$$

$$M_{2n} \geq M_2 \cdot f_s \text{ [Nm]}$$

- $M_2$  Output torque
- $M_{2n}$  Selected output torque
- $P_1$  Input power
- $\eta$  Transmission efficiency
- $f_s$  Service factor

##### 4.5 Service factor $f_s$

The effect of the driven machine on the gear unit is taken into account to a sufficient level of accuracy using the service factor  $f_s$ . The service factor is determined according to the daily operating time and the starting frequency  $Z$ . Three load classifications are considered depending on the mass acceleration factor. You can read off the service factor applicable to your application in following Figure. The service factor selected using this diagram must be less than or equal to the service factor as given in the performance parameter table.

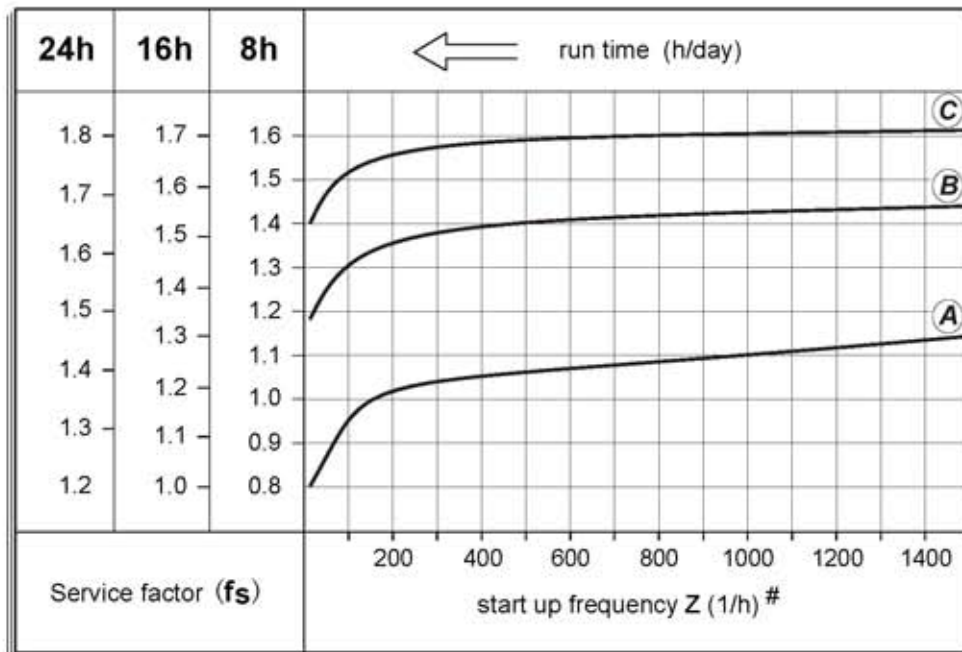

# starting frequency Z: The cycles include all starting and braking procedures as well as change overs from low to high speed.

#### 4.5.1 load classifications

- (A) Uniform, permitted mass acceleration factor  $f_a \leq 0.2$
- (B) Moderate shock load, permitted mass acceleration factor  $f_a \leq 3$
- (C) Heavy shock load, permitted mass acceleration factor  $f_a \leq 10$

Load classifications see the addendum

#### 4.5.2 Mass acceleration factor

The mass acceleration factor is calculated as follows:

$$f_a = \frac{J_c}{J_m}$$

**fa** Mass acceleration factor

**Jc** All external mass moments of inertia (  $\text{kgm}^2$  )

**Jm** Mass moment of inertia on the motor end (  $\text{kgm}^2$  )

If mass acceleration factors  $f_a > 10$ , please call our Technical Service.

To keep the service-life of gear units, the use factor  $f_s$  selected from the catalogue must be equal or slightly higher than the calculated use factor  $f_s$



#### 4.6 Radial loads $F_r$

When determining the resulting radial loads, the type of transmission elements, mounted on the shaft end must be considered. Various transmission elements are corresponding with following transmission element factors  $f_z$ :

Transmission element	Transmission element factor $F_z$	Comments
Gears	1.00	$\geq 17$ teeth
	1.15	$< 17$ teeth
Chain sprockets	1.00	$\geq 20$ teeth
	1.25	$< 20$ teeth
	1.40	$< 13$ teeth
V Narrow V-belt pulleys	1.75	Influence of the tensile force
Flat belt pulleys	2.50	Influence of the tensile force
Toothed belt pulleys	2.50	Influence of the tensile force

The overhung loads exerted on the motor or gear shaft is then calculated as follows:

$$F_r = \frac{M \cdot 2000 \cdot f_z}{d_0} \text{ [N]}$$

- $F_r$  Resulting radial load [N]
- $M$  Torque on the shaft [Nm]
- $d_0$  Mean diameter of the mounted transmission element in [mm]
- $f_z$  Transmission element factor

The basis for determining the permitted radial loads is the computation of the rated service life **LH10** of the bearings (according to **ISO 281**). For special operating conditions, the permitted radial loads can be determined with regard to the modified service life  $L_{na}$ . The permitted radial loads  $F_{r2}$  for the output shafts of foot-mounted gear units with a solid shaft are listed in the selection tables. Contact our company in case of other versions.

The permitted radial loads given in the selection tables must be calculated using the following formula in the event of force application not in the center of the shaft end. The smaller of the two values  $F_{xL}$  (according to bearing service life) and  $F_{xW}$  (according to shaft strength) is the permitted value for the radial load at point x. Note that the calculations apply to **M2 max**.

$$F_{xL} = F_{r2} \cdot \frac{a}{b+x} \text{ [N]}$$



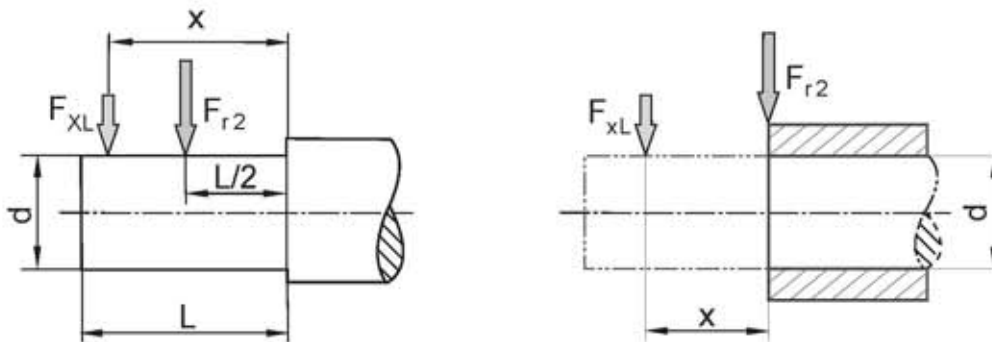

$$F_{xW} = \frac{c}{f+x} \text{ [N]}$$

- $F_{r2}$**  Permitted overhung load ( $x = L/2$ ) for foot-mounted gear units according to the selection tables in [N]
- $x$**  Distance from the shaft shoulder to the force application point in [mm]
- $a, b, f$**  Gear unit constant for overhung load conversion [mm]
- $c$**  Gear unit constant for overhung load conversion [Nmm]



Gear unit type	a [mm]	b [mm]	c [Nmm]	f [mm]	d [mm]	L [mm]
TK38	123.5	98.5	$1.41 \times 10^5$	0	25	50
TK48	153.5	123.5	$1.78 \times 10^5$	0	30	60
TK58	169.7	134.7	$6.8 \times 10^5$	31	35	70
TK68	181.3	141.3	$4.12 \times 10^5$	0	40	80
TK78	215.8	165.8	$7.69 \times 10^5$	0	50	100
TK88	252	192	$1.64 \times 10^6$	0	60	120
TK98	319	249	$2.8 \times 10^5$	0	70	140
TK108	373.5	288.5	$5.53 \times 10^6$	0	90	170
TK128	443.5	338.5	$8.31 \times 10^6$	0	110	210
TK158	509	404	$1.18 \times 10^7$	0	120	210
TK168	621.5	496.5	$1.88 \times 10^7$	0	160	250
TK188	720.5	560.5	$3.04 \times 10^7$	0	190	320

**4.7 Selection tables comments**

-  Combination with the motor in the header row **is possible**
-  Combination with the motor in the header row **is not possible**
- \*** Finite gear unit reduction ratio;
- P<sub>1n</sub>** Rated power driving motor [kW];
- n<sub>2</sub>** Output speed [r/min];
- M<sub>2n</sub>** Output torque [Nm];
- M<sub>2max</sub>** Max. permissible output torque [Nm]
- Fr<sub>2</sub>** Permissible overhung load output side [N]
- i** Gear unit ratio;
- f<sub>s</sub>** Service factor;
-  Gear unit type;
-  Motor type;
- Page** Dimension sheet page no;

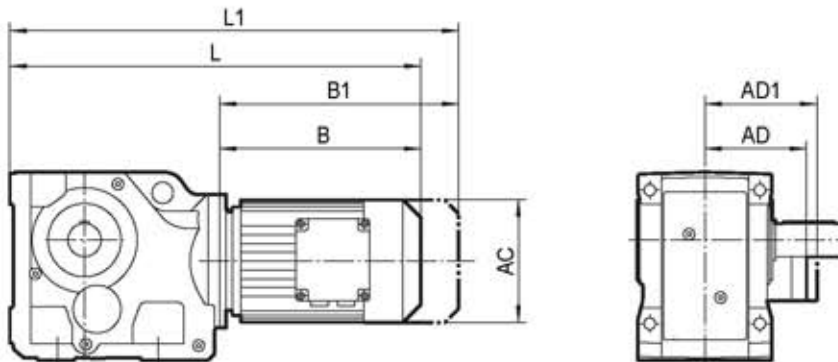

- L** Total length of gearmotor;
- L1** Total length of gearmotor including brake;
- B** Length of motor;
- B1** Length of brake motor;
- AC** Diameter of motor;
- AD** Center of motor shaft to top part of terminal box;
- AD1** Center of brake motor shaft to top part of terminal box.

## 5. SELECTION EXAMPLE

### 5.1 Gear motor

Example: Required power 30kW on driven machine, work for 16h/day, moderate shock load, so  $f_s=1.4$ , **M5** foot-mounted,  $n_2=85$  r/min

$$i = \frac{n_1}{n_2} = \frac{1400}{85} = 16.47$$

$$P_{1n} \geq P_1 \cdot f_s = \frac{P_2}{\eta} \cdot f_s = \frac{30}{0.94} \times 1.4 = 44.68 \text{ [kW]}$$

Choose type:

**TK108 - MY225M4 - 16.75 - M5**

### 5.2 Gear units

Example: Reclired torque 5000Nrn on driven machine, work 8h/day, uniform load, so  $f_s=1.1$ , flange-mounted,  $n_2 = 4$  r/min, choose TK../TRF..

$$i = \frac{n_1}{n_2} = \frac{1400}{4} = 350$$

$$M_{2n} \geq M_2 \cdot f_s = 5000 \times 1.1 = 5500 \text{ [Nm]}$$

$$P_{1n} \geq P_1 \cdot f_s = \frac{M_2 \cdot n_1}{9550 \cdot \eta \cdot i} \cdot f_s = \frac{5000 \times 1400}{9550 \times 0.94 \times 0.96 \times 350} \times 1.1 = 2.55 \text{ [kW]}$$

Choose type:

**TKF108 / TRF78 - 364**

**6. GEAR UNIT SELECTION TABLES**

**6.1 Possible geometrical combinations**

**TK..38**  $n_1=1400$  r/min **200Nm**

$n_2$ [r/min]	$M_{2max}$ [Nm]	$Fr_2$ [N]	$i$	AM / MY63 AM / MY71	AM80 MY80	AM90 MY90	AM100 MY100	AD..	$P_1$ (AD input power)
13	200	5640	106.38					AD1	0.32
14	200	5640	97.81					AD1	0.35
17	200	5640	83.69					AD1	0.41
19	200	5520	72.54					AD1	0.46
21	200	5360	67.80					AD1	0.50
24	200	5020	58.60					AD1	0.57
28	200	4660	49.79					AD1	0.66
31	200	4420	44.46					AD1	0.74
37	200	4100	37.97					AD1	0.86
39	200	3970	35.57					AD1	0.92
47	200	3650	29.96					AD2	1.1
49	200	3580	28.83					AD2	1.1
56	200	3330	24.99					AD2	1.3
60	195	3260	23.36					AD2	1.3
69	185	3110	20.19					AD2	1.5
82	180	2900	17.15					AD2	1.7
91	175	2780	15.31					AD2	1.8
107	165	2650	13.08					AD2	2.0
115	160	2600	12.14					AD2	2.1
133	160	2410	10.49					AD2	2.4
157	160	2200	8.91					AD2	2.8
176	155	2110	7.96					AD2	3.0
206	150	1980	6.80					AD2	3.4
220	145	1950	6.37					AD2	3.6
261	140	1810	5.36					AD2	4.1
352	125	1660	3.98					AD2	4.8

**Tk..38/TRF18**  $n_1=1400$  r/min **200Nm**

$n_2$ [r/min]	$M_{2max}$ [Nm]	$Fr_2$ [N]	$i$	MY63 MY71	MY80
<b>3Stage / 3Stage</b>					
0.20	200	5640	6832		
0.24	200	5640	5922		
0.25	200	5640	5491		
0.29	200	5640	4759		
0.34	200	5640	4160		
0.38	200	5640	3645		
0.44	200	5640	3205		
0.50	200	5640	2801		
0.57	200	5640	2454		
0.65	200	5640	2166		
0.74	200	5640	1891		
0.84	200	5640	1660		
0.95	200	5640	1466		
1.1	200	5640	1288		
1.2	200	5640	1136		



**TK..38/TRF18**

$n_1=1400$  r/min

**200Nm**

$n_2$ [r/min]	$M_{2max}$ [Nm]	$Fr_2$ [N]	$i$	MY63 MY71	MY80
3Stage / 2Stage					
1.4	200	5640	996		
1.6	200	5640	876		
1.8	200	5640	761		
2.1	200	5640	671		
2.4	200	5640	585		
2.7	200	5640	512		
3.1	200	5640	451		
3.5	200	5640	396		
4.0	200	5640	346		
4.6	200	5640	304		
5.2	200	5640	267		
6.0	200	5640	234		
6.8	200	5640	205		
7.7	200	5640	181		
8.8	200	5640	160		
10	200	5640	136		
11	200	5640	127		
13	200	5640	110		
15	200	5640	96		

**TK..48**

$n_1=1400$  r/min

**400Nm**

$n_2$ [r/min]	$M_{2max}$ [Nm]	$Fr_2$ [N]	$i$	AM / MY63 AM / MY71	AM80 MY80	AM90 MY90	AM100 MY100	AD..	$P_1$ (AD Input power)
11	400	5920	131.87 *					AD2	0.52
12	400	5920	121.48 *					AD2	0.55
13	400	5920	104.37					AD2	0.65
15	400	5920	90.86					AD2	0.73
16	400	5920	85.12 *					AD2	0.78
19	400	5920	75.20 *					AD2	0.88
20	400	5920	69.84					AD2	0.94
22	400	5920	63.30 *					AD2	1.0
25	400	5920	56.83					AD2	1.1
29	400	5920	48.95 *					AD2	1.3
30	400	5920	46.03 *					AD2	1.4
35	400	5920	39.61					AD2	1.6
40	400	5920	35.39					AD2	1.8
45	400	5700	31.30					AD2	2.0
48	400	5520	29.32					AD2	2.2
54	400	5170	25.91					AD2	2.4
58	400	4970	24.06					AD2	2.6
64	400	4710	21.81					AD2	2.9
72	400	4440	19.58					AD2	3.2
83	380	4230	16.86					AD2	3.5
88	380	4080	15.86					AD2	3.7
103	360	3890	13.65					AD2	4.1
115	350	3720	12.19					AD2	4.5
119	280	4060	11.77					AD2	3.7
133	280	3830	10.56					AD2	4.1
154	280	3540	9.10					AD2	4.8
164	270	3500	8.56					AD3	4.9



**TK..48**  $n_1=1400$  r/min **400Nm**

$n_2$ [r/min]	$M_{2max}$ [Nm]	$Fr_2$ [N]	$i$	AM / MY63 AM / MY71	AM80 MY80	AM90 MY90	AM100 MY100	AD..	$P_1$ (AD Input power)
190	250	3390	7.36					AD3	5.3
213	240	3270	6.58					AD3	5.7
241	230	3140	5.81					AD3	6.2
302	205	2980	4.64					AD3	6.8

**TK..48/TRF38**  $n_1=1400$  r/min **400Nm**

$n_2$ [r/min]	$M_{2max}$ [Nm]	$Fr_2$ [N]	$i$	MY63 MY71	MY80	MY90	MY100
<b>3Stage / 3Stage</b>							
0.14	400	5920	10138				
0.16	400	5920	8534				
0.18	400	5920	7662				
0.21	400	5920	6826				
0.23	400	5920	5983				
0.27	400	5920	5159				
0.30	400	5920	4601				
0.36	400	5920	3940				
0.40	400	5920	3477				
0.46	400	5920	3043				
0.51	400	5920	2733				
0.59	400	5920	2354				
0.68	400	5920	2063				
0.77	400	5920	1819				
0.88	400	5920	1586				
1.0	400	5920	1388				
<b>3Stage / 2Stage</b>							
1.1	400	5920	1222				
1.3	400	5920	1097				
1.5	400	5920	945				
1.7	400	5920	831				
1.9	400	5920	718				
2.2	400	5920	639				
2.5	400	5920	552				
2.8	400	5920	495				
3.3	400	5920	426				
3.7	400	5920	375				
4.3	400	5920	327				
4.8	400	5920	289				
5.5	400	5920	256				
6.2	400	5920	225				
7.1	400	5920	198				
8.2	400	5920	171				
9.2	400	5920	153				
11	400	5920	131				
13	400	5920	112				
14	400	5920	99				
15	400	5920	94				

POSSIBLE GEOMETRICAL COMBINATIONS

**TK..58**

$n_1=1400$  r/min

**600Nm**

$n_2$ [r/min]	$M_{2max}$ [Nm]	$Fr_2$ [N]	$i$	AM / MY63 AM / MY71	AM80 MY80	AM90 MY90	AM100 MY100	AM112 MY112	AD..	$P_1$ (AD Input power)
9.6	600	7630	145.14 *						AD2	0.69
11	600	7630	123.85						AD2	0.80
13	600	7630	108.29						AD2	0.91
14	600	7630	102.88 *						AD2	0.96
16	600	7630	90.26 *						AD2	1.1
18	600	7630	76.56 *						AD2	1.3
20	600	7630	69.12						AD2	1.4
23	600	7630	60.81 *						AD2	1.6
24	600	7630	57.42 *						AD2	1.7
29	600	7630	48.89						AD2	2.0
32	600	7630	44.43						AD2	2.2
36	600	7630	38.49						AD2	2.5
39	600	7630	35.70						AD2	2.6
46	600	7310	30.28						AD2	3.1
51	600	6930	27.34						AD2	3.4
58	600	6480	24.05						AD2	3.9
62	600	6280	22.71						AD2	4.1
72	575	5910	19.34						AD2	4.6
80	555	5740	17.57						AD2	4.9
92	535	5430	15.22						AD3	5.5
106	510	5190	13.25						AD3	6.0
117	415	5150	11.92						AD3	5.4
124	415	4990	11.26						AD3	5.7
146	405	4650	9.59						AD3	6.6
161	390	4520	8.71						AD3	7.0
185	365	4360	7.55						AD3	7.5
213	345	4190	6.57						AD3	8.2
299	300	3800	4.69						AD3	9.8

**TK..58/TRF38**

$n_1=1400$  r/min

**600Nm**

$n_2$ [r/min]	$M_{2max}$ [Nm]	$Fr_2$ [N]	$i$	MY63 MY71	MY80	MY90	MY100
3Stage / 3Stage							
0.12	600	7630	12169				
0.13	600	7630	11162				
0.15	600	7630	9503				
0.16	600	7630	8547				
0.19	600	7630	7277				
0.22	600	7630	6478				
0.25	600	7630	5662				
0.28	600	7630	5033				
0.32	600	7630	4340				
0.36	600	7630	3854				
0.41	600	7630	3390				
0.48	600	7630	2924				
0.54	600	7630	2593				
0.62	600	7630	2249				
0.70	600	7630	1986				
3Stage / 2Stage							
0.80	600	7630	1743				
0.91	600	7630	1539				
1.0	600	7630	1354				

**TK..58/TRF38**  $n_1=1400$  r/min **600Nm**

$n_2$ [r/min]	$M_2$ max [Nm]	$Fr_2$ [N]	$i$	MY63 MY71	MY80	MY90	MY100
3Stage / 2Stage							
1.2	600	7630	1174				
1.4	600	7630	1036				
1.5	600	7630	906				
1.7	600	7630	806				
2.0	600	7630	699				
2.3	600	7630	615				
2.6	600	7630	544				
3.0	600	7630	473				
3.3	600	7630	421				
3.9	600	7630	362				
4.4	600	7630	319				
5.0	600	7630	280				
5.7	600	7630	246				
6.5	600	7630	215				
7.3	600	7630	192				
8.4	600	7630	166				
9.7	600	7630	145				
11	600	7630	129				
13	600	7630	111				
14	600	7630	97				

**TK..68**  $n_1=1400$  r/min **820Nm**

$n_2$ [r/min]	$M_2$ max [Nm]	$Fr_2$ [N]	$i$	AM / MY63 AM / MY71	AM80 MY80	AM90 MY90	AM100 MY100	AM112 MY112	AM / MY132S AM / MY132M	AD..	$P_1$ (AD Input power)
9.7	820	10300	144.79 *							AD2	0.92
11	820	10300	123.54							AD2	1.1
13	820	10300	108.03							AD2	1.2
14	820	10300	102.62							AD2	1.3
16	820	10300	90.04							AD2	1.5
18	820	10300	76.37							AD2	1.7
20	820	10300	68.95							AD2	1.9
23	820	10300	60.66							AD2	2.2
24	820	10300	57.28							AD2	2.3
29	820	10300	48.77							AD2	2.7
32	820	10300	44.32							AD2	2.9
36	800	10500	38.39							AD2	3.3
39	820	10300	35.62							AD3	3.6
46	820	10300	30.22							AD3	4.3
51	820	10300	27.28							AD3	4.7
58	800	10500	24.00							AD3	5.2
62	780	10700	22.66							AD3	5.4
73	760	10800	19.30							AD3	6.1
80	740	11000	17.54							AD3	6.6
92	700	11300	15.19							AD3	7.2
106	670	11500	13.22							AD3	7.9
112	530	12300	12.48							AD3	6.6
132	500	11800	10.63							AD3	7.3
145	480	11500	9.66							AD3	7.8
167	440	11100	8.37							AD3	8.2
192	420	10700	7.28							AD3	9.0
269	350	9870	5.20							AD3	10.3

**TK..68/TRF38**

$n_1 = 1400$  r/min

**820Nm**

$n_2$ [r/min]	$M_{2max}$ [Nm]	$Fr_2$ [N]	$i$	MY63 MY71	MY80	MY90	MY100
<b>3Stage / 3Stage</b>							
0.12	820	10300	12139				
0.13	820	10300	11134				
0.15	820	10300	9479				
0.17	820	10300	8173				
0.19	820	10300	7259				
0.22	820	10300	6462				
0.25	820	10300	5648				
0.29	820	10300	4846				
0.32	820	10300	4329				
0.37	820	10300	3750				
0.42	820	10300	3315				
0.48	820	10300	2917				
0.55	820	10300	2532				
0.62	820	10300	2244				
0.71	820	10300	1981				
<b>3Stage / 2Stage</b>							
0.81	820	10300	1739				
0.91	820	10300	1535				
1.0	820	10300	1351				
1.2	820	10300	1171				
1.4	820	10300	1034				
1.6	820	10300	903				
1.8	820	10300	793				
2.0	820	10300	697				
2.3	820	10300	613				
2.6	820	10300	542				
3.0	820	10300	471				
3.3	820	10300	420				
3.9	820	10300	361				
4.3	820	10300	323				
5.0	820	10300	279				
5.7	820	10300	246				
6.5	820	10300	217				
7.3	820	10300	191				
8.4	820	10300	166				
9.7	820	10300	144				
11	820	10300	122				



**TK..78**  $n_1=1400$  r/min **1550Nm**

$n_2$ [r/min]	$M_{2max}$ [Nm]	$Fr_2$ [N]	$i$	AM / MY63 AM / MY71	AM80 MY80	AM90 MY90	AM100 MY100	AM112 MY112	AM / MY132S AM / MY132M	AM / MY132ML AM / MY160M	AD..	$P_1$ (AD Input power)
7.3	1450	16100	192.18								AD2	1.1
7.8	1450	16100	179.37								AD2	1.1
9.1	1550	15400	154.02								AD2	1.6
10	1550	15400	135.28								AD2	1.8
11	1550	15400	128.52								AD2	1.9
12	1550	15400	113.56								AD2	2.2
14	1550	15400	97.05								AD2	2.5
16	1550	15400	88.97								AD2	2.7
18	1550	15400	78.07								AD2	3.1
19	1550	15400	73.99								AD2	3.3
22	1550	15400	64.75								AD2	3.8
24	1550	15400	58.34								AD2	4.2
27	1550	15400	51.18								AD2	4.7
31	1550	15400	45.16								AD2	5.4
35	1550	15400	40.04								AD3	6.1
36	1500	15700	38.39								AD3	6.1
40	1550	15400	35.20								AD3	6.2
45	1550	15400	30.89								AD3	7.8
48	1550	15400	29.27								AD4	8.3
55	1550	15400	25.62								AD4	9.4
61	1550	15400	23.08								AD4	10.5
69	1500	15700	20.25								AD4	11.6
78	1450	16100	17.87								AD4	12.7
88	1400	15500	15.84								AD4	13.8
104	1340	14800	13.52								AD4	15.5
113	1000	15100	12.36								AD4	12.6
129	990	14400	10.84								AD4	14.2
146	940	13900	9.56								AD4	15.3
165	890	13500	8.48								AD4	16.4
193	820	13100	7.24								AD4	16.9

**TK..78/TRF38**  $n_1=1400$  r/min **1550Nm**

$n_2$ [r/min]	$M_{2max}$ [Nm]	$Fr_2$ [N]	$i$	MY63 MY71	MY80	MY90	MY100
3Stage / 3Stage							
0.09	1550	15400	15310				
0.10	1550	15400	14043				
0.12	1550	15400	11955				
0.14	1550	15400	10217				
0.16	1550	15400	8809				
0.19	1550	15400	7528				
0.21	1550	15400	6606				
0.24	1550	15400	5774				
0.28	1550	15400	5089				
0.31	1550	15400	4489				
0.35	1550	15400	3961				
0.40	1550	15400	3485				
0.48	1550	15400	2901				
0.52	1550	15400	2717				
0.59	1550	15400	2370				

POSSIBLE GEOMETRICAL COMBINATIONS

**TK..78/TRF38**

$n_1=1400$  r/min

**1550Nm**

$n_2$ [r/min]	$M_{2max}$ [Nm]	$Fr_2$ [N]	$i$	MY63 MY71	MY80	MY90	MY100
3Stage / 2Stage							
0.68	1550	15400	2050				
0.79	1550	15400	1772				
0.92	1550	15400	1514				
1.0	1550	15400	1388				
1.1	1550	15400	1218				
1.3	1550	15400	1053				
1.5	1550	15400	924				
1.7	1550	15400	815				
2.0	1550	15400	709				
2.3	1550	15400	622				
2.5	1550	15400	552				
2.9	1550	15400	485				
3.3	1550	15400	428				
3.8	1550	15400	367				
4.3	1550	15400	328				
4.8	1550	15400	290				
5.6	1550	15400	252				
6.3	1550	15400	221				
7.2	1550	15400	195				
8.0	1550	15400	175				
9.1	1550	15400	154				

**TK..88**

$n_1=1400$  r/min

**2700Nm**

$n_2$ [r/min]	$M_{2max}$ [Nm]	$Fr_2$ [N]	$i$	AM80 MY80	AM90 MY90	AM100 MY100	AM112 MY112	AM / MY132S AM / MY132M	AM / MY132ML AM / MY160M AM / MY160L	AM180 MY180	AD..	$P_1$ (AD Input power)
7.1	2700	27300	197.37								AD2	2.2
8.0	2700	27300	174.19								AD2	2.4
8.5	2700	27300	164.34 *								AD2	2.6
9.5	2700	27300	147.32 *								AD2	2.9
11	2700	27300	126.91 *								AD2	3.4
12	2700	27300	115.82								AD2	3.7
14	2700	27300	102.71 *								AD2	4.1
16	2700	27300	86.34								AD2	4.9
18	2700	27300	79.34								AD3	5.4
20	2700	27300	70.46								AD3	6.0
22	2700	26200	63.00 *								AD3	6.8
25	2700	25000	56.64								AD3	7.5
28	2700	23500	49.16								AD3	8.6
32	2600	22800	44.02								AD3	9.2
38	2500	21400	36.52 *								AD3	10.7
45	2700	19200	31.39								AD4	13.4
50	2600	18500	27.88								AD4	14.5
56	2500	18000	24.92								AD4	15.6
62	2300	17900	22.41								AD4	16.0
72	2300	16800	19.45								AD4	18.4
80	2200	16300	17.42								AD4	20
88	1800	16000	16.00								AD4	17.5
97	2100	15300	14.45								AD4	23
111	2000	14800	12.56								AD4	25
125	1500	14900	11.17								AD4	21



**TK..88**  $n_1=1400$  r/min **2700Nm**

$n_2$ [r/min]	$M_{2max}$ [Nm]	$Fr_2$ [N]	$i$	AM80 MY80	AM90 MY90	AM100 MY100	AM112 MY112	AM / MY132S AM / MY32M	AM / MY132ML AM / MY160M AM / MY160L	AM180 MY180	AD..	$P_1$ (AD Input power)
140	1500	14200	10.00								AD5	23
169	1400	13500	8.29								AD5	26
194	1300	13200	7.21								AD5	28

**TK..88/TRF58**  $n_1=1400$  r/min **2700Nm**

$n_2$ [r/min]	$M_{2max}$ [Nm]	$Fr_2$ [N]	$i$	MY63 MY71	MY80	MY90	MY100	MY112	MY132S MY132M
<b>3Stage / 3Stage</b>									
0.09	2700	27300	14829						
0.11	2700	27300	13168						
0.12	2700	27300	11737						
0.14	2700	27300	10217						
0.15	2700	27300	9073						
0.18	2700	27300	7854						
0.20	2700	27300	6832						
0.24	2700	27300	5930						
0.27	2700	27300	5240						
0.31	2700	27300	4562						
0.35	2700	27300	4037						
0.39	2700	27300	3609						
0.45	2700	27300	3107						
0.51	2700	27300	2728						
0.59	2700	27300	2371						
<b>3Stage / 2Stage</b>									
0.67	2700	27300	2088						
0.76	2700	27300	1854						
0.84	2700	27300	1657						
0.99	2700	27300	1415						
1.1	2700	27300	1229						
1.3	2700	27300	1078						
1.5	2700	27300	951						
1.7	2700	27300	837						
1.9	2700	27300	726						
2.2	2700	27300	638						
2.5	2700	27300	562						
3.0	2700	27300	474						
3.3	2700	27300	426						
3.8	2700	27300	373						
4.2	2700	27300	330						
4.8	2700	27300	294						
5.6	2700	27300	250						
5.9	2700	27300	236						
7.0	2700	27300	201						
7.7	2700	27300	183						
8.8	2700	27300	159						
9.9	2600	27400	141						

POSSIBLE GEOMETRICAL COMBINATIONS

**TK..98**

$n_1=1400$  r/min

**4300Nm**

$n_2$ [r/min]	$M_{2max}$ [Nm]	$Fr_2$ [N]	$i$	AM90 MY90	AM100 MY100	AM112 MY112	AM / MY132S AM / MY132M	AM / MY132ML AM / MY160M AM / MY160L	AM180 MY180	AM200 MY200	AD..	$P_1$ (AD Input power)
8.0	4300	40000	176.05 *								AD3	3.8
9.1	4300	40000	153.21 *								AD3	4.4
10	4300	40000	140.28								AD3	4.8
11	4300	40000	123.93 *								AD3	5.5
13	4300	40000	105.13								AD3	6.4
14	4300	40000	96.80								AD3	7.0
16	4300	38800	86.52								AD3	7.8
18	4300	37100	77.89 *								AD3	8.6
20	4300	35600	70.54								AD3	9.5
22	4300	33800	62.55								AD4	10.8
25	4300	32300	56.55								AD4	12.0
29	4300	30000	47.93 *								AD4	14.0
33	4300	28300	41.87								AD4	16.0
37	4300	27100	38.30								AD5	17.5
41	4300	25700	34.23								AD5	20
45	4300	24500	30.82								AD5	22
50	4300	23300	27.91								AD5	24
57	4300	22000	24.75								AD5	27
63	4300	20900	22.37								AD5	30
74	4300	19100	18.96								AD5	35
85	4300	17800	16.56								AD5	40
101	4300	16100	13.85								AD6	48
117	3890	16200	11.99								AD6	50
134	2870	16400	10.41								AD5	43
161	2660	15800	8.71								AD6	48
186	2400	15700	7.54								AD6	50

**TK..98/TRF58**

$n_1=1400$  r/min

**4300Nm**

$n_2$ [r/min]	$M_{2max}$ [Nm]	$Fr_2$ [N]	$i$	MY63 MY71	MY80	MY90	MY100	MY112	MY132S MY132M
3Stage / 3Stage									
0.08	4300	40000	18091						
0.08	4300	40000	16666						
0.09	4300	40000	14897						
0.11	4300	40000	13182						
0.12	4300	40000	11677						
0.14	4300	40000	10317						
0.15	4300	40000	9083						
0.17	4300	40000	8054						
0.20	4300	40000	6970						
0.23	4300	40000	6027						
0.26	4300	40000	5391						
0.30	4300	40000	4669						
0.34	4300	40000	4082						
0.39	4300	40000	3583						
0.45	4300	40000	3108						
0.51	4300	40000	2757						
3Stage / 2Stage									
0.58	4300	40000	2419						
0.66	4300	40000	2123						
0.75	4300	40000	1856						

**TK..98/TRF58**  $n_1=1400$  r/min **4300Nm**

$n_2$ [r/min]	$M_{2max}$ [Nm]	$Fr_2$ [N]	$i$	MY63 MY71	MY80	MY90	MY100	MY112	MY132S MY132M
3Stage / 2Stage									
0.86	4300	40000	1625						
0.98	4300	40000	1430						
1.1	4300	40000	1261						
1.3	4300	40000	1102						
1.5	4300	40000	957						
1.6	4300	40000	855						
1.9	4300	40000	743						
2.1	4300	40000	652						
2.4	4300	40000	573						
2.8	4300	40000	504						
3.2	4300	40000	437						
3.7	4300	40000	382						
4.1	4300	40000	342						
4.6	4300	40000	305						
5.4	4300	40000	258						
6.0	4300	40000	232						
7.0	4300	40000	199						

**TK..108**  $n_1=1400$  r/min **8000Nm**

$n_2$ [r/min]	$M_{2max}$ [Nm]	$Fr_2$ [N]	$i$	AM100 MY100	AM112 MY112	AM / MY132S AM / MY132M	AM / MY132ML AM / MY160M AM / MY160L	AM180 MY180	AM / MY200 AM / MY226S AM / MY226M	AD..	$P_1$ (AD Input power)
9.8	8000	65000	143.47*							AD4	8.8
12	8000	61500	121.46							AD4	10.3
12	8000	59300	112.41*							AD4	11.1
14	8000	56200	100.75							AD4	12.4
15	8000	53500	90.96*							AD4	13.7
17	8000	50900	82.61							AD4	15.1
19	8000	47900	73.30							AD4	17.0
21	8000	45400	66.52*							AD4	19
24	8000	41700	57.17*							AD4	22
28	7840	39300	49.90							AD4	24
33	7360	37900	42.33*							AD5	27
38	7200	35800	37.00*							AD5	30
43	7200	33200	32.69							AD5	34
45	6800	34200	31.28*							AD5	34
48	7200	30700	29.00							AD6	39
53	7200	28800	26.32							AD6	43
62	7200	25800	22.62							AD6	49
71	7200	23200	19.74							AD6	56
84	7050	21000	16.75							AD6	56
96	6890	19500	14.64							AD6	56
104	4300	29200	13.43							AD6	49
119	4300	27500	11.73							AD6	56
141	4190	25800	9.94							AD6	56
161	4070	24600	8.69							AD6	56
190	3600	24400	7.35							AD6	56



POSSIBLE GEOMETRICAL COMBINATIONS

**TK..108/TRF78**  $n_1=1400$  r/min

**8000Nm**

$n_2$ [r/min]	$M_{2max}$ [Nm]	$Fr_2$ [N]	$i$	MY63 MY71	MY80	MY90	MY100	MY112	MY132S MY132M	MY132ML MY160M
<b>3Stage / 3Stage</b>										
0.10	8000	65000	14311							
0.11	8000	65000	12211							
0.13	8000	65000	10677							
0.15	8000	65000	9524							
0.17	8000	65000	8328							
0.19	8000	65000	7270							
0.23	8000	65000	6184							
0.25	8000	65000	5662							
0.27	8000	65000	5138							
0.32	8000	65000	4359							
0.37	8000	65000	3810							
0.42	8000	65000	3358							
0.47	8000	65000	2977							
0.54	8000	65000	2599							
0.61	8000	65000	2286							
0.72	8000	65000	1939							
<b>3Stage / 2Stage</b>										
0.82	8000	65000	1713							
0.90	8000	65000	1554							
1.0	8000	65000	1336							
1.2	8000	65000	1166							
1.4	8000	65000	1030							
1.5	8000	65000	904							
1.8	8000	65000	793							
2.0	8000	65000	696							
2.3	8000	65000	615							
2.7	8000	65000	522							
3.0	8000	65000	461							
3.4	8000	65000	408							
3.8	8000	65000	364							
4.4	8000	65000	318							
4.9	8000	65000	286							
5.6	8000	65000	251							
6.3	8000	65000	222							
7.1	8000	65000	196							
8.0	7200	65000	174							
9.1	7200	65000	154							
10	7200	65000	140							

**TK..128**  $n_1=1400$  r/min **13000Nm**

$n_2$ [r/min]	$M_2$ max [Nm]	$Fr_2$ [N]	$i$	AM132M MY132M	AM / MY132ML AM / MY160M AM / MY160L	AM180 MY180	AM / MY200 AM / MY226S AM / MY226M	AM / MY260M AM / MY280	AM / MY316M AM / MY316S	AD..	$P_1$ (AD Input power)
9.6	13000	79200	146.07							AD4	13.9
10	13000	79200	136.14							AD4	14.9
11	13000	79200	122.48							AD4	16.6
13	13000	79200	110.18							AD4	18.4
16	13000	75100	89.89							AD5	23
17	13000	72100	81.98							AD5	25
20	13000	67700	70.95*							AD5	29
22	13000	64000	62.60							AD5	32
26	13000	59900	54.07							AD5	37
29	13000	56500	47.82							AD5	42
35	13000	52000	40.19							AD6	50
39	13000	49400	36.25							AD7	55
45	13000	45900	31.37							AD7	64
51	13000	43000	27.68							AD7	72
59	13000	39800	23.91							AD7	84
66	13000	37200	21.15							AD8	95
79	13000	32600	17.77							AD8	113
98	12100	31000	14.35							AD8	130
109	8530	35400	12.79							AD8	103
130	8000	33900	10.74							AD8	115
161	7230	32500	8.68							AD8	129

**TK..128/TRF78**  $n_1=1400$  r/min **13000Nm**

$n_2$ [r/min]	$M_2$ max [Nm]	$Fr_2$ [N]	$i$	MY63 MY71	MY80	MY90	MY100	MY112	MY132S MY132M	MY132ML MY160M	
3Stage / 3Stage											
0.08	13000	79200	17550								
0.09	13000	79200	16006								
0.09	13000	79200	14975								
0.11	13000	79200	12440								
0.13	13000	79200	10915								
0.14	13000	79200	9819								
0.17	13000	79200	8443								
0.19	13000	79200	7482								
0.21	13000	79200	6565								
0.24	13000	79200	5804								
0.28	13000	79200	5027								
0.32	13000	79200	4423								
0.36	13000	79200	3889								
0.42	13000	79200	3311								
0.47	13000	79200	3009								
0.54	13000	79200	2607								
0.62	13000	79200	2268								
3Stage / 2Stage											
0.73	13000	79200	1926								
0.80	13000	79200	1757								
0.91	13000	79200	1541								
1.0	13000	79200	1342								
1.2	13000	79200	1177								
1.4	13000	79200	1025								
1.6	13000	79200	899								

**TK..128/TRF78**  $n_1=1400$  r/min

**13000Nm**

$n_2$ [r/min]	$M_{2max}$ [Nm]	$Fr_2$ [N]	$i$	MY63 MY71	MY80	MY90	MY100	MY112	MY132S MY132M	MY132ML MY160M
3Stage / 2Stage										
1.8	13000	79200	790							
2.0	13000	79200	704							
2.3	13000	79200	610							
2.6	13000	79200	549							
2.9	13000	79200	477							
3.3	13000	79200	418							

**TK..128/TRF88**  $n_1=1400$  r/min

**13000Nm**

$n_2$ [r/min]	$M_{2max}$ [Nm]	$Fr_2$ [N]	$i$	MY90	MY100	MY112	MY132S MY132M	MY132ML MY160M MY160L	MY180
3Stage / 2Stage									
2.6	13000	79200	536						
3.0	13000	79200	473						
3.3	13000	79200	418						
3.8	13000	79200	367						
4.2	13000	79200	330						
4.9	13000	79200	287						
5.5	13000	79200	253						
6.6	13000	79200	213						
7.0	12000	79700	200						
8.4	12000	79700	166						
9.5	12000	79700	147						

**TK..158**  $n_1=1400$  r/min

**18000Nm**

$n_2$ [r/min]	$M_{2max}$ [Nm]	$Fr_2$ [N]	$i$	AM / MY132ML AM / MY160M AM / MY160L	AM180 MY180	AM / MY200 AM / MY226S AM / MY226M	AM / MY260M AM / MY280	AM / MY316M AM / MY316S	AM / MY316M_A AM / MY316M_B	AD..	P <sub>1</sub> (AD Input power)
9.3	18000	112200	150.41							AD5	19
11	18000	106500	122.39							AD5	23
14	18000	98000	100.22							AD5	28
15	18000	94400	91.65							AD5	31
18	18000	88900	79.75							AD5	35
20	18000	84200	70.38							AD5	40
23	18000	79000	61.02							AD5	46
26	18000	74900	54.29							AD6	52
30	18000	70000	46.79							AD7	60
37	18000	63400	38.02							AD7	73
45	18000	57500	31.30							AD8	87
51	18000	54000	27.62							AD8	89
58	18000	50000	23.95							AD8	116
66	18000	47000	21.31							AD8	130
76	18000	43200	18.37							AD8	151
94	18000	38200	14.92							AD8	186
111	17000	36700	12.65							AD8	207



**TK..158/TRF98**  $n_1=1400$  r/min **18000Nm**

$n_2$ [r/min]	$M_{2max}$ [Nm]	$Fr_2$ [N]	$i$	MY80	MY90	MY100	MY112	MY132S MY132M	MY132ML MY160M MY160L	MY180	MY200
<b>3Stage / 3Stage</b>											
0.08	18000	112200	17679								
0.09	18000	112200	15729								
0.10	18000	112200	14721								
0.11	18000	112200	13097								
0.12	18000	112200	11368								
0.14	18000	112200	10114								
0.16	18000	112200	8718								
0.18	18000	112200	7734								
0.20	18000	112200	6881								
0.24	18000	112200	5931								
0.28	18000	112200	5074								
0.31	18000	112200	4514								
0.35	18000	112200	3979								
0.40	18000	112200	3516								
0.46	18000	112200	3051								
0.54	18000	112200	2610								
0.60	18000	112200	2322								
0.69	18000	112200	2029								
0.78	18000	112200	1805								
<b>3Stage / 2Stage</b>											
0.84	18000	112200	1659								
1.0	18000	112200	1365								
1.1	18000	112200	1229								
1.3	18000	112200	1093								
1.5	18000	112200	942								
1.6	18000	112200	854								
1.9	18000	112200	756								
2.1	18000	112200	661								
2.5	18000	112200	567								
2.8	18000	112200	504								
3.2	18000	112200	434								
3.7	18000	112200	379								
4.2	18000	112200	333								
4.8	18000	112200	291								

**TK..158/TRF108**  $n_1=1400$  r/min **18000Nm**

$n_2$ [r/min]	$M_{2max}$ [Nm]	$Fr_2$ [N]	$i$	MY132S MY132M	MY132ML MY160M MY160L	MY180	MY200 MY225S MY225M
<b>3Stage / 2Stage</b>							
3.6	18000	112200	385				
4.3	18000	112200	325				
4.7	18000	112200	299				
5.5	18000	112200	253				
6.1	18000	112200	230				
6.6	18000	112200	213				
7.5	18000	112200	187				
8.9	18000	112200	157				
11	18000	106500	122				
13	18000	100700	107				

**TK..168**

$n_1=1400$  r/min

**32000Nm**

$n_2$ [r/min]	$M_2$ max [Nm]	$Fr_2$ [N]	$i$	AM / MY132ML AM / MY160M AM / MY160L	AM180 MY180	AM / MY200 AM / MY226S AM / MY226M	AM / MY260M AM / MY280	AM / MY316M AM / MY316S	AM / MY316M_A AM / MY316M_B	AD..	$P_1$ (AD Input power)
8.5	32000	150000	164.50							AD5	28
10	32000	150000	134.99							AD6	37
13	32000	150000	109.83							AD6	45
16	32000	147200	87.86							AD7	56
18	32000	140100	78.14							AD7	63
21	32000	132000	68.07							AD7	73
23	32000	125600	60.74							AD7	81
27	32000	117000	51.77							AD8	95
33	32000	107400	42.89							AD8	115
38	32000	99700	36.61							AD8	135
43	32000	93700	32.25							AD8	134
49	32000	88600	28.77							AD8	135
57	32000	81700	24.52							AD8	201
69	32000	74000	20.32							AD8	235
81	32000	67900	17.34							AD8	250

**TK..168/TRF98**

$n_1=1400$  r/min

**32000Nm**

$n_2$ [r/min]	$M_2$ max [Nm]	$Fr_2$ [N]	$i$	MY80	MY90	MY100	MY112	MY132S MY132M	MY132ML MY160M MY160L	MY180	MY200
<b>3Stage / 3Stage</b>											
0.07	32000	150000	19723								
0.08	32000	150000	17406								
0.09	32000	150000	15000								
0.11	32000	150000	13238								
0.12	32000	150000	11573								
0.14	32000	150000	10264								
0.16	32000	150000	8628								
0.21	32000	150000	6562								
0.26	32000	150000	5355								
0.29	32000	150000	4788								
0.34	32000	150000	4079								
0.41	32000	150000	3376								
0.51	32000	150000	2755								
0.62	32000	150000	2263								
<b>3Stage / 2Stage</b>											
0.64	32000	150000	2182								
0.82	32000	150000	1704								
0.99	32000	150000	1408								
1.1	32000	150000	1296								
1.3	32000	150000	1101								
1.5	32000	150000	944								
1.7	32000	150000	843								
1.8	32000	150000	757								
2.2	32000	150000	632								
2.5	32000	150000	561								
2.9	32000	150000	481								
3.3	32000	150000	423								
3.8	32000	150000	369								

**TK..168/TRF108**  $n_1=1400$  r/min **32000Nm**

$n_2$ [r/min]	$M_{2max}$ [Nm]	$Fr_2$ [N]	$i$	MY100	MY112	MY132S MY132M	MY132ML MY160M MY160L	MY180	MY200 MY225S MY225M
3Stage / 2Stage									
4.4	32000	150000	318						
5.0	32000	150000	278						
5.7	32000	150000	244						
6.6	32000	150000	213						
6.8	32000	150000	206						
7.8	32000	150000	180						
8.8	32000	150000	160						
10	32000	150000	135						
12	32000	150000	118						

**TK..188**  $n_1=1400$  r/min **50000Nm**

$n_2$ [r/min]	$M_{2max}$ [Nm]	$Fr_2$ [N]	$i$	AM / MY132ML AM / MY160M AM / MY160L	AM180 MY180	AM / MY200 AM / MY226S AM / MY226M	AM / MY260M AM / MY280	AM / MY316M AM / MY316S	AM / MY316M_A AM / MY316M_B	AD..	$P_1$ (AD Input power)
7.8	50000	190000	179.86							AD6	43
8.5	50000	190000	165.21							AD6	47
9.7	50000	190000	144.59							AD6	54
11	50000	188200	129.69							AD7	60
12	50000	177200	112.60							AD7	69
14	50000	169900	102.16							AD7	76
16	50000	159000	88.00							AD8	89
19	50000	147000	73.96							AD8	105
22	50000	137600	64.04							AD8	120
26	50000	126100	53.36							AD8	145
31	50000	116600	45.50*							AD8	170
33	50000	112700	42.51							AD8	145
36	50000	107200	38.57							AD8	160
42	50000	99100	33.23							AD8	216
50	50000	90200	27.92							AD8	239
58	47600	86800	24.18							AD8	250
69	43900	84000	20.15							AD8	250
81	41400	80800	17.18							AD8	287



**TK..188/TRF98**

$n_1=1400$  r/min

**50000Nm**

$n_2$ [r/min]	$M_{2max}$ [Nm]	$Fr_2$ [N]	$i$	MY80	MY90	MY100	MY112	MY132S MY132M	MY132ML MY160M MY160L	MY180	MY200
<b>3Stage / 3Stage</b>											
0.04	50000	189900	32625								
0.05	50000	189900	27165								
0.06	50000	189900	24353								
0.07	50000	189900	19144								
0.08	50000	189900	16978								
0.10	50000	189900	14272								
0.11	50000	189900	13116								
0.12	50000	189900	11647								
0.13	50000	189900	10413								
0.15	50000	189900	9363								
0.17	50000	189900	8126								
0.19	50000	189900	7343								
0.21	50000	189900	6747								
0.23	50000	189900	5991								
0.26	50000	189900	5358								
0.29	50000	189900	4817								
0.32	50000	189900	4370								
0.50	50000	189900	2818								
<b>3Stage / 2Stage</b>											
0.39	50000	189900	3609								
0.46	50000	189900	3062								
0.56	50000	189900	2519								
0.62	50000	189900	2268								
0.68	50000	189900	2054								
0.77	50000	189900	1821								
0.87	50000	189900	1605								
1.0	50000	189900	1395								
1.2	50000	189900	1196								
1.3	50000	189900	1046								
1.5	50000	189900	945								
1.9	50000	189900	738								
2.3	50000	189900	621								
2.7	50000	189900	527								

**TK..188/TRF108**

$n_1=1400$  r/min

**50000Nm**

$n_2$ [r/min]	$M_{2max}$ [Nm]	$Fr_2$ [N]	$i$	MY100	MY112	MY132S MY132M	MY132ML MY160M MY160L	MY180	MY200 MY225S MY225M
<b>3Stage / 2Stage</b>									
1.7	50000	189900	835						
1.9	50000	189900	729						
2.3	50000	189900	622						
2.7	50000	189900	520						
3.1	50000	189900	454						
3.9	50000	189900	355						
5.4	50000	189900	261						
6.3	50000	189900	221						
7.3	50000	189900	193						
8.6	50000	189900	163						

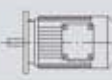

**6.2 TK..MY..Performance parameter**

$P_{1n}$ [kW]	$n_2$ [r/min]	$M_{2n}$ [Nm]	$i$	$Fr_2$ [N]	$fs$			Page
<b>0.12</b>	0.08	10900	17550	80300	1.20	TK 128 / TRF78	MY 63S4	132
	0.09	9900	16006	80700	1.30	TKF 128 / TRF78	MY 63S4	132
	0.09	9260	14975	81000	1.40	TKA 128 / TRF78	MY 63S4	132
	0.11	7690	12440	81600	1.70	TKAF 128 / TRF78	MY 63S4	132
	0.13	6750	10915	81900	1.95			
	0.14	6070	9819	82000	2.1			
	0.16	5190	8443	82300	2.5			
	0.18	4630	7482	82400	2.8			
	0.10	8850	14311	65000	0.90	TK 108 / TRF78	MY 63S4	132
	0.11	7550	12211	65000	1.05	TKF 108 / TRF78	MY 63S4	132
	0.13	6600	10677	65000	1.20	TKA 108 / TRF78	MY 63S4	132
	0.14	5890	9524	65000	1.35	TKAF 108 / TRF78	MY 63S4	132
	0.17	5150	8328	65000	1.55			
	0.19	4500	7270	65000	1.80			
	0.22	3710	6184	65000	2.2			
	0.24	3220	5662	65000	2.5			
	0.27	2920	5138	65000	2.7			
	0.32	2680	4359	65000	3.0			
	0.17	5460	8054	39400	0.80	TK 98 / TRF58	MY 63S4	132
	0.20	4430	6970	40000	0.95	TKF 98 / TRF58	MY 63S4	132
	0.23	4000	6027	40000	1.05	TKA 98 / TRF58	MY 63S4	132
	0.26	3660	5391	40000	1.20	TKAF 98 / TRF58	MY 63S4	132
	0.30	3020	4669	40000	1.40			
	0.34	2740	4082	40000	1.55			
	0.39	2380	3583	40000	1.80			
	0.44	2100	3108	40000	2.1			
	0.50	1770	2757	40000	2.4			
	0.57	1650	2419	40000	2.6			
	0.65	1430	2123	40000	3.0	TK 98 / TRF58	MY 63S4	132
	0.74	1270	1856	40000	3.4	TKF 98 / TRF58	MY 63S4	132
	0.85	1050	1625	40000	4.1	TKA 98 / TRF58	MY 63S4	132
	0.96	890	1430	40000	4.8	TKAF 98 / TRF58	MY 63S4	132
	1.1	870	1261	40000	5.0			
	1.2	755	1102	40000	5.7			
	0.26	3480	5240	26200	0.80	TK 88 / TRF58	MY 63S4	132
	0.30	2900	4562	27000	0.95	TKF 88 / TRF58	MY 63S4	132
	0.34	2680	4037	27300	1.00	TKA 88 / TRF58	MY 63S4	132
	0.38	2400	3609	27600	1.15	TKAF 88 / TRF58	MY 63S4	132
	0.44	2070	3107	28000	1.30			
	0.51	1730	2728	28300	1.55			
	0.58	1530	2371	28400	1.75			
	0.66	1430	2088	28500	1.90	TK 88 / TRF58	MY 63S4	132
0.74	1270	1854	28600	2.1	TKF 88 / TRF58	MY 63S4	132	
0.83	1140	1657	28700	2.4	TKA 88 / TRF58	MY 63S4	132	
0.97	970	1415	28800	2.8	TKAF 88 / TRF58	MY 63S4	132	
1.1	840	1229	28900	3.2				
1.3	725	1078	28900	3.7				
1.4	610	951	29000	4.4				
1.7	525	837	29000	5.2				
1.9	455	726	29000	5.9				

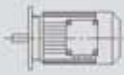
$P_{1n}$ [kW]	$n_2$ [r/min]	$M_{2n}$ [Nm]	$i$	$Fr_2$ [N]	$fs$			Page	
<b>0.12</b>	0.51	1840	2717	11500	0.85	TK	78 / TRF38	MY 63S4	132
	0.58	1530	2370	15500	1.00	TKF	78 / TRF38	MY 63S4	132
						TKA	78 / TRF38	MY 63S4	132
						TKAF	78 / TRF38	MY 63S4	132
	0.67	1440	2050	16100	1.10	TK	78 / TRF38	MY 63S4	132
	0.78	1230	1772	17300	1.25	TKF	78 / TRF38	MY 63S4	132
	0.91	1050	1514	18100	1.50	TKA	78 / TRF38	MY 63S4	132
	0.99	960	1388	18500	1.60	TKAF	78 / TRF38	MY 63S4	132
	1.1	840	1218	18900	1.85				
	1.3	740	1053	19200	2.1				
	1.5	645	924	19400	2.4				
	1.7	570	815	19600	2.7				
	1.9	450	709	19800	3.5				
	2.2	395	622	19900	3.9				
	1.0	960	1351	6940	0.85	TK	68 / TRF38	MY 63S4	132
	1.2	830	1171	10300	1.00	TKF	68 / TRF38	MY 63S4	132
	1.3	725	1034	11100	1.15	TKA	68 / TRF38	MY 63S4	132
	1.5	605	903	11900	1.35	TKAF	68 / TRF38	MY 63S4	132
	1.7	570	793	12100	1.45				
	2.0	455	697	12600	1.80				
	2.2	400	613	12800	2.0				
	2.6	350	542	13000	2.3				
	2.9	330	471	13000	2.5				
	3.3	270	420	13000	3.0				
	3.8	250	361	13000	3.3				
	4.3	220	323	13000	3.8				
	5.0	181	279	13000	4.5				
	5.6	159	246	13000	5.2				
	6.4	139	217	13000	5.9				
	1.5	605	906	7590	1.00	TK	58 / TRF38	MY 63S4	132
	1.7	545	806	8060	1.10	TKF	58 / TRF38	MY 63S4	132
	2.0	455	699	8630	1.30	TKA	58 / TRF38	MY 63S4	132
	2.2	400	615	8870	1.50	TKAF	58 / TRF38	MY 63S4	132
2.5	350	544	9080	1.70					
2.9	325	473	9190	1.85					
3.3	275	421	9390	2.2					
3.8	250	362	9470	2.4					
4.3	220	319	9570	2.8					
4.9	181	280	9690	3.3					
5.6	160	246	9760	3.8					
6.4	141	215	9810	4.3					
7.2	126	192	9850	4.8					
2.5	380	552	6170	1.05	TK	48 / TRF38	MY 63S4	132	
2.8	325	495	6840	1.25	TKF	48 / TRF38	MY 63S4	132	
3.2	290	426	7160	1.40	TKA	48 / TRF38	MY 63S4	132	
3.7	245	375	7510	1.65	TKAF	48 / TRF38	MY 63S4	132	
4.2	225	327	7620	1.75					
4.8	198	289	7780	2.0					
4.0	245	346	3540	0.80	TK	38 / TRF18	MY 63S4	132	
4.5	205	304	5570	0.95	TKF	38 / TRF18	MY 63S4	132	
5.2	189	267	5760	1.05	TKA	38 / TRF18	MY 63S4	132	
5.9	163	234	6010	1.20	TKAF	38 / TRF18	MY 63S4	132	
6.7	143	205	6180	1.40					
7.6	124	181	6300	1.60					
8.6	109	160	6400	1.85					
10	91	136	6490	2.2					

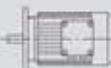
$P_{1n}$ [kW]	$n_2$ [r/min]	$M_{2n}$ [Nm]	$i$	$F_{r2}$ [N]	$f_s$			Page
<b>0.12</b>	6.2	184	144.79*	13000	4.5	TK 68	MY 63M6	100
						TKF 68	MY 63M6	101
						TKA 68	MY 63M6	102
						TKAF 68	MY 63M6	101
	6.2	185	145.14*	9680	3.3	TK 58	MY 63M6	96
	7.3	158	123.85	9760	3.8	TKF 58	MY 63M6	97
	8.3	138	108.29	9820	4.4	TKA 58	MY 63M6	98
	8.8	131	102.88*	9840	4.6	TKAF 58	MY 63M6	97
	10	115	90.26*	9880	5.2			
	12	98	76.56*	9930	6.2			
	9.5	121	145.14*	9870	5.0	TK 58	MY 63S4	96
	11	103	123.85	9920	5.8	TKF 58	MY 63S4	97
	13	90	108.29	9950	6.7	TKA 58	MY 63S4	98
	13	85	102.88*	9960	7.0	TKAF 58	MY 63S4	97
	15	75	90.26*	9990	8.0			
	6.8	168	131.87*	7930	2.4	TK 48	MY 63M6	92
	7.4	155	121.48*	7990	2.6	TKF 48	MY 63M6	93
	8.6	133	104.37	8070	3.0	TKA 48	MY 63M6	94
						TKAF 48	MY 63M6	93
	10	110	131.87*	8140	3.7	TK 48	MY 63S4	92
	11	101	121.48*	8170	4.0	TKF 48	MY 63S4	93
						TKA 48	MY 63S4	94
						TKAF 48	MY 63S4	93
	8.5	136	106.38	6230	1.50	TK 38	MY 63M6	88
	9.2	125	97.81	6300	1.60	TKF 38	MY 63M6	89
	11	107	83.69	6410	1.90	TKA 38	MY 63M6	90
	12	92	72.54	6480	2.2	TKAF 38	MY 63M6	89
	13	88	106.38	6500	2.3	TK 38	MY 63S4	88
	14	81	97.81	6530	2.5	TKF 38	MY 63S4	89
	16	70	83.69	6570	2.9	TKA 38	MY 63S4	90
	19	60	72.54	6600	3.3	TKAF 38	MY 63S4	89
	20	56	67.80	6610	3.6			
	24	49	58.60	6430	4.1			
	28	41	49.79	6130	4.8			
	31	37	44.46	5930	5.4			
	36	32	37.97	5660	6.4			
	39	30	35.57	5550	6.8			
	46	25	29.96	5270	8.0			
	48	24	28.83	5210	8.4			
	55	21	24.99	4980	9.6			
	59	19	23.36	4880	10			
	68	17	20.19	4660	11			
	80	14	17.15	4430	13			
	90	13	15.31	4280	14			
105	11	13.08	4070	15				
114	10	12.14	3970	16				
<b>0.18</b>	0.09	15800	14975	74400	0.80	TK 128 / TRF78	MY 63M4	132
	0.11	13100	12440	79100	1.00	TKF 128 / TRF78	MY 63M4	132
	0.12	11500	10915	80000	1.15	TKA 128 / TRF78	MY 63M4	132
	0.13	10300	9819	80500	1.25	TKAF 128 / TRF78	MY 63M4	132
	0.16	8870	8443	81100	1.45			
	0.18	7880	7482	81500	1.65			
	0.20	6920	6565	81800	1.90			
	0.23	5890	5804	82100	2.2			

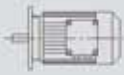

$P_{1n}$ [kW]	$n_2$ [r/min]	$M_{2n}$ [Nm]	$i$	$Fr_2$ [N]	$fs$			Page
<b>0.18</b>	0.26	5210	5027	82300	2.5	TK 128 / TRF78	MY 63M4	132
	0.30	4490	4423	82400	2.9	TKF 128 / TRF78	MY 63M4	132
	0.34	3910	3889	82500	3.3	TKA 128 / TRF78	MY 63M4	132
	0.40	3250	3311	82600	4.0	TKAF 128 / TRF78	MY 63M4	132
	0.16	8780	8328	65000	0.90	TK 108 / TRF78	MY 63M4	132
	0.18	7660	7270	65000	1.05	TKF 108 / TRF78	MY 63M4	132
	0.21	6410	6184	65000	1.25	TKA 108 / TRF78	MY 63M4	132
	0.23	5690	5662	65000	1.40	TKAF 108 / TRF78	MY 63M4	132
	0.26	5160	5138	65000	1.55			
	0.30	4580	4359	65000	1.75			
	0.35	4010	3810	65000	2.0			
	0.39	3410	3358	65000	2.4			
	0.44	3090	2977	65000	2.6			
	0.51	2690	2599	65000	3.0			
	0.58	2320	2286	65000	3.5			
	0.28	5060	4669	39800	0.85	TK 98 / TRF58	MY 63M4	132
	0.32	4540	4082	40000	0.95	TKF 98 / TRF58	MY 63M4	132
	0.37	3940	3583	40000	1.10	TKA 98 / TRF58	MY 63M4	132
	0.42	3450	3108	40000	1.25	TKAF 98 / TRF58	MY 63M4	132
	0.48	2990	2757	40000	1.45			
	0.55	2720	2419	40000	1.60	TK 98 / TRF58	MY 63M4	132
	0.62	2360	2123	40000	1.80	TKF 98 / TRF58	MY 63M4	132
	0.71	2090	1856	40000	2.1	TKA 98 / TRF58	MY 63M4	132
	0.81	1760	1625	40000	2.4	TKAF 98 / TRF58	MY 63M4	132
	0.92	1530	1430	40000	2.8			
	1.1	1420	1261	40000	3.0			
	1.2	1240	1102	40000	3.5			
	1.4	1090	957	40000	4.0			
	1.5	970	855	40000	4.4			
	1.8	775	743	40000	5.6			
	2.0	690	652	40000	6.2			
	0.42	3440	3107	26200	0.80	TK 88 / TRF58	MY 63M4	132
	0.48	2920	2728	27000	0.90	TKF 88 / TRF58	MY 63M4	132
	0.56	2570	2371	27500	1.05	TKA 88 / TRF58	MY 63M4	132
						TKAF 88 / TRF58	MY 63M4	132
	0.63	2350	2088	27700	1.15	TK 88 / TRF58	MY 63M4	132
	0.71	2090	1854	28000	1.30	TKF 88 / TRF58	MY 63M4	132
	0.80	1870	1657	28200	1.45	TKA 88 / TRF58	MY 63M4	132
	0.93	1590	1415	28400	1.70	TKAF 88 / TRF58	MY 63M4	132
	1.1	1380	1229	28600	1.95			
	1.2	1200	1078	28700	2.3			
	1.4	1030	951	28800	2.6			
	1.6	890	837	28800	3.0			
	1.8	775	726	28900	3.5			
	0.87	1720	1514	14100	0.90	TK 78 / TRF38	MY 63M4	132
	0.95	1570	1388	15200	1.00	TKF 78 / TRF38	MY 63M4	132
	1.1	1380	1218	16500	1.10	TKA 78 / TRF38	MY 63M4	132
	1.2	1200	1053	17400	1.30	TKAF 78 / TRF38	MY 63M4	132
1.4	1050	924	18100	1.45				
1.6	930	815	18600	1.65				
1.9	760	709	19100	2.0				
2.1	670	622	19300	2.3				
2.4	600	552	19500	2.6				
2.7	530	485	19600	2.9				
3.1	465	428	19800	3.3				
3.6	410	367	19800	3.8				

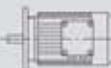

$P_{1n}$ [kW]	$n_2$ [r/min]	$M_{2n}$ [Nm]	$i$	$F_{r2}$ [N]	$f_s$			Page	
<b>0.18</b>	1.7	930	793	9240	0.90	TK	68 / TRF38	MY 63M4	132
	1.9	765	697	10800	1.05	TKF	68 / TRF38	MY 63M4	132
	2.1	670	613	11500	1.20	TKA	68 / TRF38	MY 63M4	132
	2.4	590	542	12000	1.40	TKAF	68 / TRF38	MY 63M4	132
	2.8	540	471	12200	1.50				
	3.1	455	420	12600	1.80				
	3.6	410	361	12800	2.0				
	4.1	360	323	12900	2.3				
	4.7	305	279	13000	2.7				
	2.4	590	544	7690	1.00	TK	58 / TRF38	MY 63M4	132
	2.8	535	473	8150	1.10	TKF	58 / TRF38	MY 63M4	132
	3.1	460	421	8620	1.30	TKA	58 / TRF38	MY 63M4	132
	3.6	410	362	8840	1.45	TKAF	58 / TRF38	MY 63M4	132
	4.1	360	319	9050	1.65				
	4.7	305	280	9270	1.95				
	5.4	270	246	9400	2.2				
	6.1	235	215	9510	2.5				
	6.9	210	192	9600	2.9				
	7.9	182	166	9690	3.3				
	3.5	410	375	5600	1.00	TK	48 / TRF38	MY 63M4	132
	4.0	370	327	6320	1.10	TKF	48 / TRF38	MY 63M4	132
	4.6	325	289	6810	1.20	TKA	48 / TRF38	MY 63M4	132
	5.2	280	256	7240	1.45	TKAF	48 / TRF38	MY 63M4	132
	5.9	250	225	7450	1.60				
	6.7	215	198	7680	1.85				
	7.7	188	171	7840	2.1				
	8.6	168	153	7930	2.4				
	10	147	131	8020	2.7				
	6.4	235	205	4860	0.85	TK	38 / TRF18	MY 63M4	132
	7.3	205	181	5590	1.00	TKF	38 / TRF18	MY 63M4	132
	8.2	180	160	5860	1.10	TKA	38 / TRF18	MY 63M4	132
	9.7	151	136	6110	1.35	TKAF	38 / TRF18	MY 63M4	132
	10	145	127	6160	1.40				
	6.0	285	144.79*	13000	2.9	TK	68	MY 63L6	100
	7.0	245	123.54	13000	3.4	TKF	68	MY 63L6	101
	8.1	215	108.03	13000	3.8	TKA	68	MY 63L6	102
	8.5	205	102.62	13000	4.0	TKAF	68	MY 63L6	101
	9.1	189	144.79*	13000	4.4	TK	68	MY 63M4	100
	11	161	123.54	13000	5.1	TKF	68	MY 63M4	101
	12	141	108.03	13000	5.8	TKA	68	MY 63M4	102
						TKAF	68	MY 63M4	101
	6.0	285	145.14*	9340	2.1	TK	58	MY 63L6	96
	7.0	245	123.85	9480	2.5	TKF	58	MY 63L6	97
	8.0	215	108.29	9590	2.8	TKA	58	MY 63L6	98
	8.5	205	102.88*	9620	3.0	TKAF	58	MY 63L6	97
	9.6	178	90.26*	9700	3.4				
	9.1	189	145.14*	9670	3.2	TK	58	MY 63M4	96
11	161	123.85	9750	3.7	TKF	58	MY 63M4	97	
12	141	108.29	9810	4.3	TKA	58	MY 63M4	98	
13	134	102.88*	9830	4.5	TKAF	58	MY 63M4	97	
15	118	90.26*	9880	5.1					
17	100	76.56*	9920	6.0					
6.6	260	131.87*	7380	1.55	TK	48	MY 63L6	92	
7.2	240	121.48*	7530	1.65	TKF	48	MY 63L6	93	
8.3	205	104.37	7740	1.95	TKA	48	MY 63L6	94	
9.6	180	90.86	7880	2.2	TKAF	48	MY 63L6	93	
10	168	85.12*	7930	2.4					

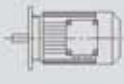
$P_{1n}$ [kW]	$n_2$ [r/min]	$M_{2n}$ [Nm]	$i$	$Fr_2$ [N]	$fs$			Page	
0.18	10	172	131.87*	7910	2.3	TK 48	MY 63M4	92	
	11	158	121.48*	7970	2.5	TKF 48	MY 63M4	93	
	13	136	104.37	8060	2.9	TKA 48	MY 63M4	94	
	15	118	90.86	8120	3.4	TKAF 48	MY 63M4	93	
	16	111	85.12*	8140	3.6				
	8.2	210	106.38	5520	0.95	TK 38	MY 63L6	88	
	8.9	193	97.81	5710	1.05	TKF 38	MY 63L6	89	
	10	165	83.69	5990	1.20	TKA 38	MY 63L6	90	
	12	143	72.54	6170	1.40	TKAF 38	MY 63L6	89	
	12	139	106.38	6210	1.45	TK 38	MY 63M4	88	
	14	127	97.81	6280	1.55	TKF 38	MY 63M4	89	
	16	109	83.69	6400	1.85	TKA 38	MY 63M4	90	
	18	95	72.54	6470	2.1	TKAF 38	MY 63M4	89	
	19	88	67.80	6500	2.3				
	23	76	58.60	6280	2.6				
	27	65	49.79	6010	3.1				
	30	58	44.46	5830	3.5				
	35	49	37.97	5580	4.1				
	37	46	35.57	5480	4.3				
	44	39	29.96	5220	5.1				
	46	38	28.83	5160	5.3				
	53	33	24.99	4950	6.2				
	57	30	23.36	4850	6.4				
	65	26	20.19	4650	7.0				
	77	22	17.15	4430	8.1				
	86	20	15.31	4280	8.8				
	101	17	13.08	4080	9.7				
	109	16	12.14	3980	10				
	126	14	10.49	3810	12				
	148	12	8.91	3620	14				
	166	10	7.96	3490	15				
	0.25	0.13	15200	9819	75600	0.85	TK 128 / TRF78	MY 63L4	132
		0.15	13000	8443	79200	1.00	TKF 128 / TRF78	MY 63L4	132
0.17		11600	7482	79900	1.10	TKA 128 / TRF78	MY 63L4	132	
0.20		10200	6565	80600	1.30	TKAF 128 / TRF78	MY 63L4	132	
0.22		8750	5804	81200	1.50				
0.26		7690	5027	81600	1.70				
0.29		6670	4423	81900	1.95				
0.33		5830	3889	82100	2.2				
0.39		4880	3311	82300	2.7				
0.21		9460	6184	65000	0.85	TK 108 / TRF78	MY 63L4	132	
0.23		8480	5662	65000	0.95	TKF 108 / TRF78	MY 63L4	132	
0.25		7700	5138	65000	1.05	TKA 108 / TRF78	MY 63L4	132	
0.30		6730	4359	65000	1.20	TKAF 108 / TRF78	MY 63L4	132	
0.34		5880	3810	65000	1.35				
0.39		5060	3358	65000	1.60				
0.44		4550	2977	65000	1.75				
0.50		3980	2599	65000	2.0				
0.57		3450	2286	65000	2.3				
0.67		2920	1939	65000	2.7				
0.76		2680	1713	65000	3.0	TK 108 / TRF78	MY 63L4	132	
0.84		2430	1554	65000	3.3	TKF 108 / TRF78	MY 63L4	132	
0.97	2090	1336	65000	3.8	TKA 108 / TRF78	MY 63L4	132		
						TKAF 108 / TRF78	MY 63L4	132	

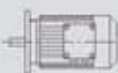
$P_{1n}$ [kW]	$n_2$ [r/min]	$M_{2n}$ [Nm]	$i$	$F_{r2}$ [N]	$f_s$			Page	
<b>0.25</b>	0.42	4990	3108	39900	0.85	TK	98 / TRF58	MY 63L4	132
	0.47	4360	2757	40000	1.00	TKF	98 / TRF58	MY 63L4	132
						TKA	98 / TRF58	MY 63L4	132
						TKAF	98 / TRF58	MY 63L4	132
	0.54	3930	2419	40000	1.10	TK	98 / TRF58	MY 63L4	132
	0.61	3420	2123	40000	1.25	TKF	98 / TRF58	MY 63L4	132
	0.70	3020	1856	40000	1.40	TKA	98 / TRF58	MY 63L4	132
	0.80	2580	1625	40000	1.65	TKAF	98 / TRF58	MY 63L4	132
	0.91	2240	1430	40000	1.90				
	1.0	2050	1261	40000	2.1				
	1.2	1790	1102	40000	2.4				
	1.4	1570	957	40000	2.7				
	1.5	1400	855	40000	3.1				
	0.62	3390	2088	26300	0.80	TK	88 / TRF58	MY 63L4	132
	0.70	3010	1854	26900	0.90	TKF	88 / TRF58	MY 63L4	132
	0.78	2700	1657	27300	1.00	TKA	88 / TRF58	MY 63L4	132
	0.92	2300	1415	27800	1.15	TKAF	88 / TRF58	MY 63L4	132
	1.1	2000	1229	28100	1.35				
	1.2	1740	1078	28300	1.55				
	1.4	1510	951	28500	1.80				
	1.6	1310	837	28600	2.1				
	1.8	1140	726	28700	2.4				
	2.0	1010	638	28800	2.7				
	1.2	1730	1053	14000	0.90	TK	78 / TRF38	MY 63L4	132
	1.4	1520	924	15600	1.00	TKF	78 / TRF38	MY 63L4	132
	1.6	1340	815	16700	1.15	TKA	78 / TRF38	MY 63L4	132
	1.8	1120	709	17800	1.40	TKAF	78 / TRF38	MY 63L4	132
	2.1	980	622	18400	1.60				
	2.4	880	552	18700	1.75				
	2.7	770	485	19100	2.0				
	3.0	680	428	19300	2.3				
	3.5	595	367	19500	2.6				
	4.0	525	328	19600	2.9				
	4.5	470	290	19700	3.3				
	5.2	400	252	19900	3.9				
	5.9	355	221	19900	4.4				
	6.7	310	195	20000	5.0				
	7.5	275	175	20000	5.7				
	2.1	980	613	5690	0.85	TK	68 / TRF38	MY 63L4	132
	2.4	860	542	9920	0.95	TKF	68 / TRF38	MY 63L4	132
	2.8	775	471	10700	1.05	TKA	68 / TRF38	MY 63L4	132
	3.1	665	420	11500	1.25	TKAF	68 / TRF38	MY 63L4	132
	3.6	590	361	11900	1.40				
	4.0	525	323	12300	1.55				
	4.7	445	279	12700	1.85				
	5.3	390	246	12800	2.1				
	6.0	345	217	13000	2.4				
	3.1	670	421	4200	0.90	TK	58 / TRF38	MY 63L4	132
	3.6	590	362	7690	1.00	TKF	58 / TRF38	MY 63L4	132
	4.1	520	319	8260	1.15	TKA	58 / TRF38	MY 63L4	132
	4.7	445	280	8680	1.35	TKAF	58 / TRF38	MY 63L4	132
	5.3	390	246	8920	1.55				
	6.0	345	215	9110	1.75				
	6.8	305	192	9260	1.95				
	7.8	265	166	9410	2.3				

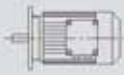

$P_{1n}$ [kW]	$n_2$ [r/min]	$M_{2n}$ [Nm]	$i$	$Fr_2$ [N]	$fs$			Page	
0.25	9.0	230	145	9530	2.6	TK	58 / TRF38	MY 63L4	132
	10	210	129	9600	2.9	TKF	58 / TRF38	MY 63L4	132
	12	178	111	9700	3.4	TKA	58 / TRF38	MY 63L4	132
	13	156	97	9770	3.8	TKAF	58 / TRF38	MY 63L4	132
	4.4	540	154.02	19600	2.9	TK	78	MY 80N8	104
	5.0	475	135.28	19700	3.3	TKF	78	MY 80N8	105
	5.3	450	128.52	19800	3.4	TKA	78	MY 80N8	106
	6.0	400	113.56	19900	3.9	TKAF	78	MY 80N8	105
	4.6	520	192.18	19700	2.8	TK	78	MY 71D6	104
	4.9	485	179.37	19700	3.0	TKF	78	MY 71D6	105
	5.7	420	154.02	19800	3.7	TKA	78	MY 71D6	106
	6.5	365	135.28	19900	4.2	TKAF	78	MY 71D6	105
	5.5	435	123.54	12700	1.90	TK	68	MY 80N8	100
	6.3	380	108.03	12900	2.2	TKF	68	MY 80N8	101
	6.6	360	102.62	12900	2.3	TKA	68	MY 80N8	102
	7.5	315	90.04	13000	2.6	TKAF	68	MY 80N8	101
	6.1	395	144.79*	12800	2.1	TK	68	MY 71D6	100
	7.1	335	123.54	13000	2.5	TKF	68	MY 71D6	101
	8.2	295	108.03	13000	2.8	TKA	68	MY 71D6	102
	8.6	280	102.62	13000	3.0	TKAF	68	MY 71D6	101
	9.0	265	144.79*	13000	3.1	TK	68	MY 63L4	100
	11	225	123.54	13000	3.6	TKF	68	MY 63L4	101
	12	198	108.03	13000	4.1	TKA	68	MY 63L4	102
	13	189	102.62	13000	4.4	TKAF	68	MY 63L4	101
	6.1	395	145.14*	8910	1.50	TK	58	MY 71D6	96
	7.1	335	123.85	9150	1.80	TKF	58	MY 71D6	97
	8.1	295	108.29	9310	2.0	TKA	58	MY 71D6	98
	8.6	280	102.88*	9360	2.2	TKAF	58	MY 71D6	97
	9.8	245	90.26*	9480	2.5				
	11	210	76.56*	9610	2.9				
	9.0	265	145.14*	9410	2.3	TK	58	MY 63L4	96
	11	225	123.85	9540	2.6	TKF	58	MY 63L4	97
	12	199	108.29	9640	3.0	TKA	58	MY 63L4	98
	13	189	102.88*	9670	3.2	TKAF	58	MY 63L4	97
	14	166	90.26*	9740	3.6				
	17	141	76.56*	9810	4.3				
	6.7	360	131.87*	6470	1.10	TK	48	MY 71D6	92
	7.2	330	121.48*	6780	1.20	TKF	48	MY 71D6	93
	8.4	285	104.37	7210	1.40	TKA	48	MY 71D6	94
	9.7	245	90.86	7480	1.60	TKAF	48	MY 71D6	93
	10	230	85.12*	7590	1.75				
	9.9	240	131.87*	7510	1.65	TK	48	MY 63L4	92
	11	225	121.48*	7640	1.80	TKF	48	MY 63L4	93
	12	192	104.37	7820	2.1	TKA	48	MY 63L4	94
14	167	90.86	7930	2.4	TKAF	48	MY 63L4	93	
15	156	85.12*	7980	2.6					
11	225	83.69	5300	0.90	TK	38	MY 71D6	88	
12	197	72.54	5680	1.00	TKF	38	MY 71D6	89	
13	184	67.80	5810	1.10	TKA	38	MY 71D6	90	
15	159	58.60	6050	1.25	TKAF	38	MY 71D6	89	
18	135	49.79	6230	1.50					
12	195	106.38	5690	1.00	TK	38	MY 63L4	88	
13	180	97.81	5860	1.10	TKF	38	MY 63L4	89	
16	154	83.69	6090	1.30	TKA	38	MY 63L4	90	
18	133	72.54	6250	1.50	TKAF	38	MY 63L4	89	
19	125	67.80	6230	1.60					

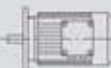

$P_{1n}$ [kW]	$n_2$ [r/min]	$M_{2n}$ [Nm]	$i$	$F_{r2}$ [N]	$f_s$			Page
<b>0.25</b>	22	108	58.60	6030	1.85	TK 38	MY 63L4	88
	26	91	49.79	5810	2.2	TKF 38	MY 63L4	89
	29	82	44.46	5650	2.5	TKA 38	MY 63L4	90
	34	70	37.97	5430	2.9	TKAF 38	MY 63L4	89
	37	65	35.57	5340	3.1			
	43	55	29.96	5100	3.6			
	45	53	28.83	5050	3.8			
	52	46	24.99	4860	4.4			
	56	43	23.36	4770	4.6			
	64	37	20.19	4580	5.0			
	76	32	17.15	4370	5.7			
	85	28	15.31	4230	6.2			
	99	24	13.08	4030	6.9			
	107	22	12.14	3940	7.2			
	124	19	10.49	3780	8.3			
	146	16	8.91	3590	9.8			
	163	15	7.96	3470	11			
	191	13	6.80	3310	12			
	204	12	6.37	3240	12			
	<b>0.37</b>	0.18	16600	7482	72700	0.80	TK 128 / TRF78	MY 71D4
0.21		14500	6565	76900	0.90	TKF 128 / TRF78	MY 71D4	132
0.24		12600	5804	79400	1.05	TKA 128 / TRF78	MY 71D4	132
0.27		11000	5027	80200	1.20	TKAF 128 / TRF78	MY 71D4	132
0.31		9610	4423	80800	1.35			
0.35		8420	3889	81300	1.55			
0.42		7080	3311	81800	1.85			
0.72		4280	1926	82400	3.0	TK 128 / TRF78	MY 71D4	132
0.79		3900	1757	82500	3.3	TKF 128 / TRF78	MY 71D4	132
0.90		3390	1541	82600	3.8	TKA 128 / TRF78	MY 71D4	132
						TKAF 128 / TRF78	MY 71D4	132
0.36		8420	3810	65000	0.95	TK 108 / TRF78	MY 71D4	132
0.41		7300	3358	65000	1.10	TKF 108 / TRF78	MY 71D4	132
0.46		6540	2977	65000	1.20	TKA 108 / TRF78	MY 71D4	132
0.53		5710	2599	65000	1.40	TKAF 108 / TRF78	MY 71D4	132
0.60		4970	2286	65000	1.60			
0.71		4210	1939	65000	1.90			
0.81		3830	1713	65000	2.1	TK 108 / TRF78	MY 71D4	132
0.89		3480	1554	65000	2.3	TKF 108 / TRF78	MY 71D4	132
1.0		2990	1336	65000	2.7	TKA 108 / TRF78	MY 71D4	132
1.2		2610	1166	65000	3.1	TKAF 108 / TRF78	MY 71D4	132
0.65		4860	2123	40000	0.90	TK 98 / TRF58	MY 71D4	132
0.74		4270	1856	40000	1.00	TKF 98 / TRF58	MY 71D4	132
0.85		3670	1625	40000	1.15	TKA 98 / TRF58	MY 71D4	132
0.96		3200	1430	40000	1.35	TKAF 98 / TRF58	MY 71D4	132
1.1		2900	1261	40000	1.50			
1.2		2540	1102	40000	1.70			
1.4		2220	957	40000	1.95			
1.6		1990	855	40000	2.2			
1.9		1640	743	40000	2.6			
2.1		1450	652	40000	3.0			
2.4		1310	573	40000	3.3			
0.97		3250	1415	26500	0.85	TK 88 / TRF58	MY 71D4	132
1.1		2820	1229	27100	0.95	TKF 88 / TRF58	MY 71D4	132
1.3		2470	1078	27600	1.10	TKA 88 / TRF58	MY 71D4	132
1.4		2150	951	27900	1.25	TKAF 88 / TRF58	MY 71D4	132
1.7		1880	837	28200	1.45			

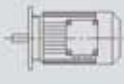
$P_{1n}$ [kW]	$n_2$ [r/min]	$M_{2n}$ [Nm]	$i$	$Fr_2$ [N]	$fs$			Page	
0.37	1.9	1630	726	28400	1.65	TK	88 / TRF58	MY 71D4	132
	2.2	1440	638	28500	1.85	TKF	88 / TRF58	MY 71D4	132
	2.5	1260	562	28600	2.2	TKA	88 / TRF58	MY 71D4	132
	2.9	1060	474	28800	2.6	TKAF	88 / TRF58	MY 71D4	132
	3.2	950	426	28800	2.8				
	3.7	830	373	28900	3.2				
	1.7	1890	815	7450	0.80	TK	78 / TRF38	MY 71D4	132
	1.9	1590	709	15100	0.95	TKF	78 / TRF38	MY 71D4	132
	2.2	1400	622	16400	1.10	TKA	78 / TRF38	MY 71D4	132
	2.5	1250	552	17200	1.25	TKAF	78 / TRF38	MY 71D4	132
	2.9	1100	485	17900	1.40				
	3.2	970	428	18400	1.60				
	3.8	840	367	18900	1.85				
	4.2	750	328	19100	2.1				
	4.8	665	290	19400	2.3				
	5.5	570	252	19600	2.7				
	6.2	500	221	19700	3.1				
	7.1	445	195	19800	3.5				
	7.9	390	175	19900	4.0				
	9.0	345	154	19900	4.5				
	3.3	950	420	8130	0.85	TK	68 / TRF38	MY 71D4	132
	3.8	840	361	10200	1.00	TKF	68 / TRF38	MY 71D4	132
	4.3	745	323	10900	1.10	TKA	68 / TRF38	MY 71D4	132
	5.0	630	279	11700	1.30	TKAF	68 / TRF38	MY 71D4	132
	5.6	555	246	12100	1.50				
	6.4	495	217	12400	1.65				
	7.2	435	191	12700	1.90				
	8.3	375	166	12900	2.2				
	9.6	330	144	13000	2.5				
	11	280	122	13000	2.9				
	4.9	635	280	7350	0.95	TK	58 / TRF38	MY 71D4	132
	5.6	555	246	7980	1.10	TKF	58 / TRF38	MY 71D4	132
	6.4	490	215	8460	1.20	TKA	58 / TRF38	MY 71D4	132
	7.2	435	192	8720	1.40	TKAF	58 / TRF38	MY 71D4	132
	8.3	380	166	8980	1.60				
	9.6	330	145	9170	1.80				
	11	300	129	9290	2.0				
	12	255	111	9460	2.4				
	14	225	97	9560	2.7				
	3.9	910	174.19	28800	3.0	TK	88	MY 90S8	108
	4.1	850	164.34*	28900	3.2	TKF	88	MY 90S8	109
	4.6	765	147.32*	28900	3.5	TKA	88	MY 90S8	110
						TKAF	88	MY 90S8	109
	4.6	775	197.37	28900	3.5	TK	88	MY 80K6	108
	5.2	685	174.19	28900	4.0	TKF	88	MY 80K6	109
						TKA	88	MY 80K6	110
						TKAF	88	MY 80K6	109
5.0	705	135.28	19300	2.2	TK	78	MY 90S8	104	
5.3	670	128.52	19300	2.3	TKF	78	MY 90S8	105	
6.0	590	113.56	19500	2.6	TKA	78	MY 90S8	106	
7.0	505	97.05	19700	3.1	TKAF	78	MY 90S8	105	
5.8	605	154.02	19500	2.6	TK	78	MY 80K6	104	
6.7	530	135.28	19600	2.9	TKF	78	MY 80K6	105	
7.0	505	128.52	19700	3.1	TKA	78	MY 80K6	106	
7.9	445	113.56	19800	3.5	TKAF	78	MY 80K6	105	

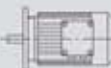
$P_{1n}$ [kW]	$n_2$ [r/min]	$M_{2n}$ [Nm]	$i$	$F_{r2}$ [N]	$f_s$			Page
<b>0.37</b>	7.2	490	192.18	19700	3.0	TK 78	MY 71D4	104
	7.7	460	179.37	19800	3.2	TKF 78	MY 71D4	105
	9.0	395	154.02	19900	3.9	TKA 78	MY 71D4	106
						TKAF 78	MY 71D4	105
	6.3	560	108.03	12100	1.45	TK 68	MY 90S8	100
	6.6	535	102.62	12300	1.55	TKF 68	MY 90S8	101
	7.5	470	90.04	12600	1.75	TKA 68	MY 90S8	102
						TKAF 68	MY 90S8	101
	7.3	485	123.54	12500	1.70	TK 68	MY 80K6	100
	8.3	425	108.03	12700	1.95	TKF 68	MY 80K6	101
	8.8	405	102.62	12800	2.0	TKA 68	MY 80K6	102
	10	355	90.04	13000	2.3	TKAF 68	MY 80K6	101
	9.5	370	144.79*	12900	2.2	TK 68	MY 71D4	100
	11	315	123.54	13000	2.6	TKF 68	MY 71D4	101
	13	275	108.03	13000	3.0	TKA 68	MY 71D4	102
	15	230	90.04	13000	3.6	TKAF 68	MY 71D4	101
	18	196	76.37	13000	4.2			
	7.3	485	123.85	8490	1.25	TK 58	MY 80K6	96
	8.3	425	108.29	8770	1.40	TKF 58	MY 80K6	97
	8.8	405	102.88*	8870	1.50	TKA 58	MY 80K6	98
	10	355	90.26*	9070	1.70	TKAF 58	MY 80K6	97
	12	300	76.56*	9280	2.0			
	13	270	69.12	9390	2.2			
	9.5	370	145.14*	9000	1.60	TK 58	MY 71D4	96
	11	315	123.85	9220	1.90	TKF 58	MY 71D4	97
	13	275	108.29	9370	2.2	TKA 58	MY 71D4	98
	13	265	102.88*	9420	2.3	TKAF 58	MY 71D4	97
	15	230	90.26*	9530	2.6			
	18	196	76.56*	9650	3.1			
	20	177	69.12	9700	3.4			
	8.6	410	104.37	5490	1.00	TK 48	MY 80K6	92
	9.9	355	90.86	6480	1.10	TKF 48	MY 80K6	93
	11	335	85.12*	6730	1.20	TKA 48	MY 80K6	94
	12	295	75.20*	7100	1.35	TKAF 48	MY 80K6	93
	10	340	131.87*	6690	1.20	TK 48	MY 71D4	92
	11	310	121.48*	6960	1.30	TKF 48	MY 71D4	93
	13	265	104.37	7330	1.50	TKA 48	MY 71D4	94
						TKAF 48	MY 71D4	93
	15	235	90.86	7580	1.70	TK 48	MY 71D4	92
	16	220	85.12*	7670	1.85	TKF 48	MY 71D4	93
	18	193	75.20*	7810	2.1	TKA 48	MY 71D4	94
	20	179	69.84	7880	2.2	TKAF 48	MY 71D4	93
	22	162	63.30*	7960	2.5			
	14	250	97.81	2520	0.80	TK 38	MY 71D4	88
	16	215	83.69	5470	0.95	TKF 38	MY 71D4	89
	19	186	72.54	5690	1.10	TKA 38	MY 71D4	90
	20	174	67.80	5630	1.15	TKAF 38	MY 71D4	89
	24	150	58.60	5510	1.35			
	28	128	49.79	5350	1.55			
	31	114	44.46	5230	1.75			
36	97	37.97	5060	2.1				
39	91	35.57	4990	2.2				
46	77	29.96	4800	2.6				
48	74	28.83	4750	2.7				
55	64	24.99	4590	3.1				
59	60	23.36	4510	3.3				

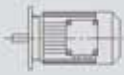

$P_{1n}$ [kW]	$n_2$ [r/min]	$M_{2n}$ [Nm]	$i$	$Fr_2$ [N]	$fs$			Page
0.37	68	52	20.19	4350	3.6	TK 38	MY 71D4	88
	80	44	17.15	4160	4.1	TKF 38	MY 71D4	89
	90	39	15.31	4040	4.5	TKA 38	MY 71D4	90
	105	34	13.08	3860	4.9	TKAF 38	MY 71D4	89
	114	31	12.14	3780	5.1			
	132	27	10.49	3630	6.0			
	155	23	8.91	3460	7.0			
	173	20	7.96	3350	7.6			
	203	17	6.80	3190	8.6			
	217	16	6.37	3130	8.9			
	257	14	5.36	2970	10			
0.55	0.08	55000	16978	190000	0.90	TK 188 / TRF98	MY 80K4	132
	0.10	46200	14272	190000	1.10	TKH 188 / TRF98	MY 80K4	132
	0.10	42000	13116	190000	1.20			
	0.12	36700	11647	190000	1.35			
	0.19	23800	7343	190000	2.1			
	0.12	37500	11573	150000	0.85	TK 168 / TRF98	MY 80K4	132
	0.13	33300	10264	150000	0.95	TKH 168 / TRF98	MY 80K4	132
	0.16	27900	8628	150000	1.15			
	0.21	21200	6562	150000	1.50			
	0.25	16900	5355	150000	1.90			
	0.33	13100	4079	150000	2.5			
	0.20	22300	6881	109700	0.80	TK 158 / TRF98	MY 80K4	132
	0.23	19200	5931	111600	0.95	TKF 158 / TRF98	MY 80K4	132
	0.34	12900	3979	114400	1.40	TKA 158 / TRF98	MY 80K4	132
	0.45	9880	3051	115300	1.80	TKAF 158 / TRF98	MY 80K4	132
	0.31	14900	4423	76100	0.85	TK 128 / TRF78	MY 80K4	132
	0.35	13100	3889	79100	1.00	TKF 128 / TRF78	MY 80K4	132
	0.41	11100	3311	80200	1.20	TKA 128 / TRF78	MY 80K4	132
	0.45	10000	3009	80700	1.30	TKAF 128 / TRF78	MY 80K4	132
	0.52	8590	2607	81200	1.50			
	0.71	6620	1926	81900	1.95	TK 128 / TRF78	MY 80K4	132
	0.77	6040	1757	82100	2.2	TKF 128 / TRF78	MY 80K4	132
	0.88	5270	1541	82200	2.5	TKA 128 / TRF78	MY 80K4	132
	1.0	4610	1342	82400	2.8	TKAF 128 / TRF78	MY 80K4	132
	1.2	4020	1177	82500	3.2			
	1.3	3520	1025	82600	3.7			
	0.46	10100	2977	65000	0.80	TK 108 / TRF78	MY 80K4	132
	0.52	8830	2599	65000	0.90	TKF 108 / TRF78	MY 80K4	132
	0.59	7720	2286	65000	1.05	TKA 108 / TRF78	MY 80K4	132
	0.70	6540	1939	65000	1.20	TKAF 108 / TRF78	MY 80K4	132
	0.79	5920	1713	65000	1.35	TK 108 / TRF78	MY 80K4	132
	0.87	5370	1554	65000	1.50	TKF 108 / TRF78	MY 80K4	132
	1.0	4610	1336	65000	1.75	TKA 108 / TRF78	MY 80K4	132
	1.2	4030	1166	65000	2.0	TKAF 108 / TRF78	MY 80K4	132
	1.3	3460	1030	65000	2.3			
	1.5	3010	904	65000	2.7			
	1.7	2730	793	65000	2.9			
	1.9	2380	696	65000	3.4			
	2.2	2050	615	65000	3.9			
	0.95	4940	1430	40000	0.85	TK 98 / TRF58	MY 80K4	132
	1.1	4440	1261	40000	0.95	TKF 98 / TRF58	MY 80K4	132
	1.2	3870	1102	40000	1.10	TKA 98 / TRF58	MY 80K4	132
	1.4	3400	957	40000	1.25	TKAF 98 / TRF58	MY 80K4	132
	1.6	3040	855	40000	1.40			
	1.8	2550	743	40000	1.70			

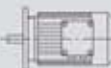

$P_{1n}$ [kW]	$n_2$ [r/min]	$M_{2n}$ [Nm]	$i$	$F_{r2}$ [N]	$f_s$			Page	
<b>0.55</b>	2.1	2250	652	40000	1.90	TK	98 / TRF58	MY 80K4	132
	2.4	2020	573	40000	2.1	TKF	98 / TRF58	MY 80K4	132
	2.7	1720	504	40000	2.5	TKA	98 / TRF58	MY 80K4	132
	3.1	1480	437	40000	2.9	TKAF	98 / TRF58	MY 80K4	132
	3.6	1320	382	40000	3.3				
	4.5	1070	305	40000	4.0				
	1.4	3300	951	26400	0.80	TK	88 / TRF58	MY 80K4	132
	1.6	2890	837	27000	0.95	TKF	88 / TRF58	MY 80K4	132
	1.9	2510	726	27500	1.10	TKA	88 / TRF58	MY 80K4	132
	2.1	2220	638	27800	1.20	TKAF	88 / TRF58	MY 80K4	132
	2.4	1940	562	28100	1.40				
	2.9	1640	474	28400	1.65				
	3.2	1470	426	28500	1.85				
	3.6	1290	373	28600	2.1				
	4.1	1130	330	28700	2.4				
	4.6	1010	294	28800	2.7				
	5.4	870	250	28800	3.1				
	5.8	820	236	28900	3.3				
	6.8	695	201	28900	3.9				
	2.8	1690	485	14300	0.90	TK	78 / TRF38	MY 80K4	132
	3.2	1490	428	15800	1.05	TKF	78 / TRF38	MY 80K4	132
	3.7	1290	367	17000	1.20	TKA	78 / TRF38	MY 80K4	132
	4.2	1150	328	17700	1.35	TKAF	78 / TRF38	MY 80K4	132
	4.7	1020	290	18200	1.50				
	5.4	880	252	18700	1.75				
	6.2	770	221	19100	2.0				
	7.0	680	195	19300	2.3				
	7.8	605	175	19500	2.6				
	8.8	535	154	19600	2.9				
	4.9	970	279	6400	0.85	TK	68 / TRF38	MY 80K4	132
	5.5	850	246	9990	0.95	TKF	68 / TRF38	MY 80K4	132
	6.2	760	217	10800	1.10	TKA	68 / TRF38	MY 80K4	132
	7.1	670	191	11500	1.25	TKAF	68 / TRF38	MY 80K4	132
	8.2	575	166	12000	1.40				
	9.4	505	144	12400	1.60				
	11	430	122	12700	1.90				
	7.1	670	192	4080	0.90	TK	58 / TRF38	MY 80K4	132
	8.2	580	166	7800	1.05	TKF	58 / TRF38	MY 80K4	132
	9.4	510	145	8360	1.20	TKA	58 / TRF38	MY 80K4	132
	11	455	129	8630	1.30	TKAF	58 / TRF38	MY 80K4	132
	12	390	111	8930	1.55				
	14	340	97	9120	1.75				
	3.9	1350	174.19	28600	2.0	TK	88	MY 90L8	108
	4.1	1270	164.34*	28600	2.1	TKF	88	MY 90L8	109
	4.6	1140	147.32*	28700	2.4	TKA	88	MY 90L8	110
					TKAF	88	MY 90L8	109	
4.6	1150	197.37	28700	2.3	TK	88	MY 80N6	108	
5.2	1020	174.19	28800	2.7	TKF	88	MY 80N6	109	
5.5	960	164.34*	28800	2.8	TKA	88	MY 80N6	110	
6.1	860	147.32*	28900	3.1	TKAF	88	MY 80N6	109	
5.0	1040	135.28	18100	1.50	TK	78	MY 90L8	104	
5.3	990	128.52	18300	1.55	TKF	78	MY 90L8	105	
6.0	880	113.56	18700	1.75	TKA	78	MY 90L8	106	
7.0	750	97.05	19100	2.1	TKAF	78	MY 90L8	105	

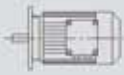
$P_{1n}$ [kW]	$n_2$ [r/min]	$M_{2n}$ [Nm]	$i$	$Fr_2$ [N]	$fs$			Page
0.55	5.8	900	154.02	18700	1.70	TK 78	MY 80N6	104
	6.7	790	135.28	19000	1.95	TKF 78	MY 80N6	105
	7.0	750	128.52	19100	2.1	TKA 78	MY 80N6	106
	7.9	665	113.56	19400	2.3	TKAF 78	MY 80N6	105
	8.8	595	154.02	19500	2.6	TK 78	MY 80K4	104
	10	520	135.28	19700	3.0	TKF 78	MY 80K4	105
	11	495	128.52	19700	3.1	TKA 78	MY 80K4	106
	12	440	113.56	19800	3.5	TKAF 78	MY 80K4	105
	14	375	97.05	19900	4.1			
	7.3	720	123.54	11100	1.15	TK 68	MY 80N6	100
	8.3	630	108.03	11700	1.30	TKF 68	MY 80N6	101
	8.8	600	102.62	11900	1.35	TKA 68	MY 80N6	102
	10	525	90.04	12300	1.55	TKAF 68	MY 80N6	101
	12	445	76.37	12600	1.85			
	11	475	123.54	12500	1.70	TK 68	MY 80K4	100
	13	415	108.03	12800	1.95	TKF 68	MY 80K4	101
	15	350	90.04	13000	2.4	TKA 68	MY 80K4	102
	18	295	76.37	13000	2.8	TKAF 68	MY 80K4	101
	8.3	630	108.29	7360	0.95	TK 58	MY 80N6	96
	8.8	600	102.88*	7630	1.00	TKF 58	MY 80N6	97
	10	525	90.26*	8220	1.15	TKA 58	MY 80N6	98
	12	445	76.56*	8670	1.35	TKAF 58	MY 80N6	97
	13	405	69.12	8870	1.50			
	15	355	60.81*	9070	1.70			
	16	335	57.42*	9150	1.80			
	11	480	123.85	8520	1.25	TK 58	MY 80K4	96
	13	420	108.29	8800	1.45	TKF 58	MY 80K4	97
	13	395	102.88*	8890	1.50	TKA 58	MY 80K4	98
	15	350	90.26*	9100	1.70	TKAF 58	MY 80K4	97
	18	295	76.56*	9300	2.0			
	20	265	69.12	9410	2.3			
	22	235	60.81*	9520	2.6			
	24	220	57.42*	9560	2.7			
	13	405	104.37	5880	1.00	TK 48	MY 80K4	92
	15	350	90.86	6550	1.15	TKF 48	MY 80K4	93
	16	330	85.12*	6790	1.20	TKA 48	MY 80K4	94
	18	290	75.20*	7150	1.40	TKAF 48	MY 80K4	93
	19	270	69.84	7310	1.50			
	21	245	63.30*	7500	1.65	TK 48	MY 80K4	92
	24	220	56.83	7660	1.80	TKF 48	MY 80K4	93
	28	189	48.95*	7830	2.1	TKA 48	MY 80K4	94
	30	178	46.03*	7880	2.3	TKAF 48	MY 80K4	93
	23	225	58.60	4850	0.90	TK 38	MY 80K4	88
	27	192	49.79	4790	1.05	TKF 38	MY 80K4	89
	31	172	44.46	4740	1.15	TKA 38	MY 80K4	90
	36	147	37.97	4640	1.35	TKAF 38	MY 80K4	89
	38	137	35.57	4600	1.45			
	45	116	29.96	4470	1.75			
	47	111	28.83	4440	1.80			
	54	97	24.99	4320	2.1			
	58	90	23.36	4260	2.2			
	67	78	20.19	4130	2.4			
	79	66	17.15	3980	2.7			
	89	59	15.31	3880	3.0			
	104	51	13.08	3730	3.3			
	112	47	12.14	3660	3.4			

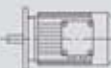
$P_{1n}$ [kW]	$n_2$ [r/min]	$M_{2n}$ [Nm]	$i$	$F_{r2}$ [N]	$f_s$			Page
<b>0.55</b>	130	41	10.49	3520	4.0	TK 38	MY 80K4	88
	153	34	8.91	3370	4.7	TKF 38	MY 80K4	89
	171	31	7.96	3270	5.1	TKA 38	MY 80K4	90
	200	26	6.80	3130	5.7	TKAF 38	MY 80K4	89
	214	25	6.37	3070	5.9			
	254	21	5.36	2920	6.8			
	342	15	3.98	2680	8.1			
<b>0.75</b>	0.11	58000	13116	190000	0.85	TK 188 / TRF98	MY 80N4	132
	0.12	50900	11647	190000	1.00	TKH 188 / TRF98	MY 80N4	132
	0.19	32700	7343	190000	1.55			
	0.20	29900	6747	190000	1.65			
	0.23	26200	5991	190000	1.90			
	0.16	38500	8628	150000	0.85	TK 168 / TRF98	MY 80N4	132
	0.21	29300	6562	150000	1.10	TKH 168 / TRF98	MY 80N4	132
	0.26	23400	5355	150000	1.35			
	0.34	18100	4079	150000	1.75			
	0.41	15100	3376	150000	2.1			
	0.35	17700	3979	112300	1.00	TK 158 / TRF98	MY 80N4	132
	0.45	13600	3051	114100	1.30	TKF 158 / TRF98	MY 80N4	132
						TKA 158 / TRF98	MY 80N4	132
						TKAF 158 / TRF98	MY 80N4	132
	0.83	7490	1659	115900	2.4	TK 158 / TRF98	MY 80N4	132
	1.0	6040	1365	116200	3.0	TKF 158 / TRF98	MY 80N4	132
						TKA 158 / TRF98	MY 80N4	132
						TKAF 158 / TRF98	MY 80N4	132
	0.42	15100	3311	75700	0.85	TK 128 / TRF78	MY 80N4	132
	0.46	13700	3009	78600	0.95	TKF 128 / TRF78	MY 80N4	132
	0.53	11800	2607	79800	1.10	TKA 128 / TRF78	MY 80N4	132
						TKAF 128 / TRF78	MY 80N4	132
	0.72	9010	1926	81100	1.45	TK 128 / TRF78	MY 80N4	132
	0.79	8220	1757	81400	1.60	TKF 128 / TRF78	MY 80N4	132
	0.90	7180	1541	81700	1.80	TKA 128 / TRF78	MY 80N4	132
	1.0	6280	1342	82000	2.1	TKAF 128 / TRF78	MY 80N4	132
	1.2	5480	1177	82200	2.4			
	1.4	4790	1025	82300	2.7			
	1.5	4190	899	82500	3.1			
	0.81	8040	1713	65000	1.00	TK 108 / TRF78	MY 80N4	132
	0.89	7300	1554	65000	1.10	TKF 108 / TRF78	MY 80N4	132
	1.0	6270	1336	65000	1.30	TKA 108 / TRF78	MY 80N4	132
	1.2	5470	1166	65000	1.45	TKAF 108 / TRF78	MY 80N4	132
	1.3	4740	1030	65000	1.70			
	1.5	4130	904	65000	1.95			
	1.7	3710	793	65000	2.2			
2.0	3240	696	65000	2.5				
2.2	2810	615	65000	2.8				
1.2	5240	1102	39600	0.80	TK 98 / TRF58	MY 80N4	132	
1.4	4600	957	40000	0.95	TKF 98 / TRF58	MY 80N4	132	
1.6	4110	855	40000	1.05	TKA 98 / TRF58	MY 80N4	132	
1.9	3470	743	40000	1.25	TKAF 98 / TRF58	MY 80N4	132	
2.1	3050	652	40000	1.40				
2.4	2740	573	40000	1.55				
2.7	2350	504	40000	1.85				
3.2	2020	437	40000	2.1				
3.6	1790	382	40000	2.4				

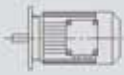

P <sub>1n</sub> [kW]	n <sub>2</sub> [r/min]	M <sub>2n</sub> [Nm]	i	Fr <sub>2</sub> [N]	fs			Page	
0.75	4.5	1450	305	40000	3.0	TK	98 / TRF58	MY 80N4	132
	5.4	1220	258	40000	3.5	TKF	98 / TRF58	MY 80N4	132
	6.0	1100	232	40000	3.9	TKA	98 / TRF58	MY 80N4	132
	6.9	940	199	40000	4.6	TKAF	98 / TRF58	MY 80N4	132
	1.9	3410	726	26300	0.80	TK	88 / TRF58	MY 80N4	132
	2.2	3010	638	26900	0.90	TKF	88 / TRF58	MY 80N4	132
	2.5	2640	562	27400	1.00	TKA	88 / TRF58	MY 80N4	132
	2.9	2220	474	27800	1.20	TKAF	88 / TRF58	MY 80N4	132
	3.2	2000	426	28100	1.35				
	3.7	1760	373	28300	1.55				
	4.2	1540	330	28400	1.75				
	4.7	1370	294	28600	1.95				
	5.5	1190	250	28700	2.3				
	5.8	1120	236	28700	2.4				
	6.9	950	201	28800	2.9				
	3.8	1740	367	13900	0.90	TK	78 / TRF38	MY 80N4	132
	4.2	1550	328	15400	1.00	TKF	78 / TRF38	MY 80N4	132
	4.8	1380	290	16500	1.15	TKA	78 / TRF38	MY 80N4	132
	5.5	1190	252	17500	1.30	TKAF	78 / TRF38	MY 80N4	132
	6.2	1040	221	18100	1.50				
	3.9	1830	176.05*	40000	2.4	TK	98	MY 100M8	112
	4.5	1590	153.21*	40000	2.7	TKF	98	MY 100M8	113
	4.9	1460	140.28	40000	3.0	TKA	98	MY 100M8	114
						TKAF	98	MY 100M8	113
	4.7	1530	147.32*	28500	1.75	TK	88	MY 100M8	108
	5.4	1320	126.91*	28600	2.1	TKF	88	MY 100M8	109
	6.0	1200	115.82	28700	2.3	TKA	88	MY 100M8	110
	6.7	1070	102.71*	28700	2.5	TKAF	88	MY 100M8	109
	5.2	1390	174.19	28600	1.95	TK	88	MY 90S6	108
	5.5	1310	164.34*	28600	2.1	TKF	88	MY 90S6	109
	6.1	1170	147.32*	28700	2.3	TKA	88	MY 90S6	110
	7.1	1010	126.91*	28800	2.7	TKAF	88	MY 90S6	109
	7.0	1020	197.37	28800	2.6	TK	88	MY 80N4	108
	7.9	900	174.19	28800	3.0	TKF	88	MY 80N4	109
	8.4	850	164.34*	28900	3.2	TKA	88	MY 80N4	110
	9.4	765	147.32*	28900	3.5	TKAF	88	MY 80N4	109
	6.7	1080	135.28	18000	1.45	TK	78	MY 90S6	104
	7.0	1020	128.52	18200	1.50	TKF	78	MY 90S6	105
	7.9	900	113.56	18700	1.70	TKA	78	MY 90S6	106
	9.3	770	97.05	19100	2.0	TKAF	78	MY 90S6	105
	10	710	88.97	19200	2.2				
	9.0	800	154.02	19000	1.95	TK	78	MY 80N4	104
	10	700	135.28	19300	2.2	TKF	78	MY 80N4	105
	11	665	128.52	19300	2.3	TKA	78	MY 80N4	106
	12	590	113.56	19500	2.6	TKAF	78	MY 80N4	105
14	505	97.05	19700	3.1					
11	640	123.54	11700	1.30	TK	68	MY 80N4	100	
13	560	108.03	12100	1.45	TKF	68	MY 80N4	101	
15	465	90.04	12600	1.75	TKA	68	MY 80N4	102	
					TKAF	68	MY 80N4	101	
18	395	76.37	12800	2.1	TK	68	MY 80N4	100	
20	360	68.95	13000	2.3	TKF	68	MY 80N4	101	
23	315	60.66	13000	2.6	TKA	68	MY 80N4	102	
24	295	57.28	13000	2.8	TKAF	68	MY 80N4	101	

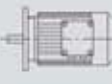

$P_{1n}$ [kW]	$n_2$ [r/min]	$M_{2n}$ [Nm]	$i$	$F_{r2}$ [N]	$f_s$			Page	
<b>0.75</b>	11	645	123.85	7130	0.95	TK 58	MY 80N4	96	
	13	560	108.29	7940	1.05	TKF 58	MY 80N4	97	
	13	535	102.88*	8160	1.10	TKA 58	MY 80N4	98	
	15	470	90.26*	8570	1.30	TKAF 58	MY 80N4	97	
	18	395	76.56*	8890	1.50				
	20	360	69.12	9060	1.65				
	23	315	60.81*	9230	1.90				
	24	300	57.42*	9290	2.0				
	28	255	48.89	9450	2.4				
	31	230	44.43	9530	2.6				
	18	390	75.20*	6060	1.00	TK 48	MY 80N4	92	
	20	365	69.84	6410	1.10	TKF 48	MY 80N4	93	
	22	330	63.30*	6790	1.20	TKA 48	MY 80N4	94	
						TKAF 48	MY 80N4	93	
	24	295	56.83	7110	1.35	TK 48	MY 80N4	92	
	28	255	48.95*	7430	1.55	TKF 48	MY 80N4	93	
	30	240	46.03*	7540	1.65	TKA 48	MY 80N4	94	
	35	205	39.61	7740	1.95	TKAF 48	MY 80N4	93	
	39	184	35.39	7760	2.2				
	44	162	31.30	7550	2.5				
	31	230	44.46	4170	0.85	TK 38	MY 80N4	88	
	36	197	37.97	4150	1.00	TKF 38	MY 80N4	89	
	39	185	35.57	4140	1.10	TKA 38	MY 80N4	90	
	46	156	29.96	4080	1.30	TKAF 38	MY 80N4	89	
	48	150	28.83	4060	1.35				
	55	130	24.99	3990	1.55				
	59	121	23.36	3950	1.60				
	68	105	20.19	3860	1.75				
	80	89	17.15	3750	2.0				
	90	80	15.31	3670	2.2				
	105	68	13.08	3550	2.4				
	114	63	12.14	3500	2.5				
	132	54	10.49	3380	2.9				
	155	46	8.91	3250	3.5				
	173	41	7.96	3160	3.8				
	203	35	6.80	3030	4.3				
	217	33	6.37	2980	4.4				
	257	28	5.36	2840	5.0				
	347	21	3.98	2620	6.0				
	<b>1.1</b>	0.15	59700	9363	190000	0.85	TK 188 / TRF98	MY 90S4	132
		0.17	51100	8126	190000	1.00	TKH 188 / TRF98	MY 90S4	132
		0.19	48400	7343	190000	1.05			
		0.21	44200	6747	190000	1.15			
		0.23	39000	5991	190000	1.30			
		0.26	34500	5358	190000	1.45			
		0.29	30700	4817	190000	1.65			
		0.32	27900	4370	190000	1.80			
0.26		34800	5355	150000	0.90	TK 168 / TRF98	MY 90S4	132	
0.29		30800	4788	150000	1.05	TKH 168 / TRF98	MY 90S4	132	
0.34		26700	4079	150000	1.20				
0.41		22300	3376	150000	1.45				
0.51		17900	2755	150000	1.80				
0.64		14600	2182	150000	2.2	TK 168 / TRF98	MY 90S4	132	
0.82		11300	1704	150000	2.8	TKH 168 / TRF98	MY 90S4	132	
0.99		9390	1408	150000	3.4				
1.1		8600	1296	150000	3.7				

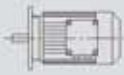
$P_{1n}$ [kW]	$n_2$ [r/min]	$M_{2n}$ [Nm]	$i$	$Fr_2$ [N]	$fs$			Page
1.1	0.40	22700	3516	109500	0.80	TK 158 / TRF98	MY 90S4	132
	0.46	20100	3051	111100	0.90	TKF 158 / TRF98	MY 90S4	132
	0.54	16700	2610	112800	1.10	TKA 158 / TRF98	MY 90S4	132
	0.60	14800	2322	113600	1.20	TKAF 158 / TRF98	MY 90S4	132
	0.84	11100	1659	115000	1.65	TK 158 / TRF98	MY 90S4	132
	1.0	8980	1365	115600	2.0	TKF 158 / TRF98	MY 90S4	132
	1.1	8010	1229	115800	2.3	TKA 158 / TRF98	MY 90S4	132
	1.3	7130	1093	116000	2.5	TKAF 158 / TRF98	MY 90S4	132
	1.5	6150	942	116100	2.9			
	1.6	5510	854	116200	3.3			
	0.73	13200	1926	79100	1.00	TK 128 / TRF78	MY 90S4	132
	0.80	12000	1757	79700	1.10	TKF 128 / TRF78	MY 90S4	132
	0.91	10500	1541	80500	1.25	TKA 128 / TRF78	MY 90S4	132
	1.0	9170	1342	81000	1.40	TKAF 128 / TRF78	MY 90S4	132
	1.2	8020	1177	81400	1.60			
	1.4	7010	1025	81800	1.85			
	1.6	6130	899	82000	2.1			
	1.8	5280	790	82200	2.5			
	2.0	4780	704	82300	2.7			
	2.3	4110	610	82500	3.2			
	2.6	3710	549	82500	3.5			
	2.9	3190	477	82600	4.1			
	1.2	7990	1166	65000	1.00	TK 108 / TRF78	MY 90S4	132
	1.4	6960	1030	65000	1.15	TKF 108 / TRF78	MY 90S4	132
	1.6	6080	904	65000	1.30	TKA 108 / TRF78	MY 90S4	132
	1.8	5420	793	65000	1.50	TKAF 108 / TRF78	MY 90S4	132
	2.0	4740	696	65000	1.70			
	2.3	4140	615	65000	1.95			
	2.7	3510	522	65000	2.3			
	3.0	3090	461	65000	2.6			
	3.4	2720	408	65000	2.9			
	3.9	2470	364	65000	3.2			
	4.4	2160	318	65000	3.7			
	1.9	5070	743	39800	0.85	TK 98 / TRF58	MY 90S4	132
	2.1	4460	652	40000	0.95	TKF 98 / TRF58	MY 90S4	132
	2.4	3990	573	40000	1.10	TKA 98 / TRF58	MY 90S4	132
	2.8	3430	504	40000	1.25	TKAF 98 / TRF58	MY 90S4	132
	3.2	2970	437	40000	1.45			
	3.7	2620	382	40000	1.65			
	4.1	2320	342	40000	1.85			
	3.0	3250	474	26500	0.85	TK 88 / TRF58	MY 90S4	132
	3.3	2920	426	27000	0.90	TKF 88 / TRF58	MY 90S4	132
	3.8	2570	373	27400	1.05	TKA 88 / TRF58	MY 90S4	132
	4.2	2250	330	27800	1.20	TKAF 88 / TRF58	MY 90S4	132
4.8	2010	294	28000	1.35				
5.6	1730	250	28300	1.55				
5.9	1630	236	28400	1.65				
7.0	1390	201	28600	1.95				
3.8	2760	176.05*	40000	1.55	TK 98	MY 100L8	112	
4.4	2400	153.21*	40000	1.80	TKF 98	MY 100L8	113	
4.8	2200	140.28	40000	1.95	TKA 98	MY 100L8	114	
5.4	1940	123.93*	40000	2.2	TKAF 98	MY 100L8	113	
5.2	2010	176.05*	40000	2.1	TK 98	MY 90L6	112	
6.0	1750	153.21*	40000	2.5	TKF 98	MY 90L6	113	
6.6	1600	140.28	40000	2.7	TKA 98	MY 90L6	114	
7.4	1420	123.93*	40000	3.0	TKAF 98	MY 90L6	113	

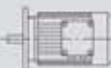
$P_{1n}$ [kW]	$n_2$ [r/min]	$M_{2n}$ [Nm]	$i$	$Fr_2$ [N]	$fs$			Page
<b>1.1</b>	8.0	1320	176.05*	40000	3.3	TK 98	MY 90S4	112
	9.1	1150	153.21*	40000	3.7	TKF 98	MY 90S4	113
	10	1050	140.28	40000	4.1	TKA 98	MY 90S4	114
						TKAF 98	MY 90S4	113
	5.3	1990	174.19	28100	1.35	TK 88	MY 90L6	108
	5.6	1880	164.34*	28200	1.45	TKF 88	MY 90L6	109
	6.2	1680	147.32*	28300	1.60	TKA 88	MY 90L6	110
	7.2	1450	126.91*	28500	1.85	TKAF 88	MY 90L6	109
	8.0	1310	174.19	28600	2.1	TK 88	MY 90S4	108
	8.5	1230	164.34*	28700	2.2	TKF 88	MY 90S4	109
	9.5	1110	147.32*	28700	2.4	TKA 88	MY 90S4	110
	11	950	126.91*	28800	2.8	TKAF 88	MY 90S4	109
	12	870	115.82	28800	3.1			
	6.8	1540	135.28	15400	1.00	TK 78	MY 90L6	104
	7.2	1470	128.52	15900	1.05	TKF 78	MY 90L6	105
	8.1	1300	113.56	17000	1.20	TKA 78	MY 90L6	106
	9.5	1110	97.05	17900	1.40	TKAF 78	MY 90L6	105
	10	1020	135.28	18300	1.55	TK 78	MY 90S4	104
	11	960	128.52	18400	1.60	TKF 78	MY 90S4	105
	12	850	113.56	18800	1.80	TKA 78	MY 90S4	106
						TKAF 78	MY 90S4	105
	14	730	97.05	19200	2.1	TK 78	MY 90S4	104
	16	670	88.97	19300	2.3	TKF 78	MY 90S4	105
	18	585	78.07	19500	2.7	TKA 78	MY 90S4	106
	19	555	73.99	19600	2.8	TKAF 78	MY 90S4	105
	13	810	108.03	10400	1.00	TK 68	MY 90S4	100
	14	770	102.62	10700	1.05	TKF 68	MY 90S4	101
	16	675	90.04	11400	1.20	TKA 68	MY 90S4	102
	18	575	76.37	12000	1.45	TKAF 68	MY 90S4	101
	20	515	68.95	12300	1.60			
	23	455	60.66	12600	1.80	TK 68	MY 90S4	100
	24	430	57.28	12700	1.90	TKF 68	MY 90S4	101
	29	365	48.77	12900	2.2	TKA 68	MY 90S4	102
	32	335	44.32	13000	2.5	TKAF 68	MY 90S4	101
	36	290	38.39	13000	2.8			
	16	675	90.26*	2410	0.90	TK 58	MY 90S4	96
	18	575	76.56*	7840	1.05	TKF 58	MY 90S4	97
	20	520	69.12	8280	1.15	TKA 58	MY 90S4	98
	23	455	60.81*	8630	1.30	TKAF 58	MY 90S4	97
	24	430	57.42*	8750	1.40			
	29	365	48.89	9020	1.65			
	32	335	44.43	9160	1.80			
	36	290	38.49	9330	2.1	TK 58	MY 90S4	96
	39	270	35.70	9400	2.2	TKF 58	MY 90S4	97
	46	225	30.28	9540	2.6	TKA 58	MY 90S4	98
	51	205	27.34	9510	2.9	TKAF 58	MY 90S4	97
58	181	24.05	9220	3.3				
62	170	22.71	9090	3.5				
72	145	19.34	8720	4.0				
80	132	17.57	8510	4.2				
92	114	15.22	8180	4.7				
106	99	13.25	7880	5.1				
117	90	11.92	7570	4.6				
124	85	11.26	7450	4.9				
146	72	9.59	7120	5.6				



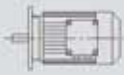

$P_{1n}$ [kW]	$n_2$ [r/min]	$M_{2n}$ [Nm]	$i$	$Fr_2$ [N]	$fs$			Page	
<b>1.1</b>	161	65	8.71	6930	6.0	TK 58	MY 90S4	96	
	186	57	7.55	6650	6.5	TKF 58	MY 90S4	97	
	213	49	6.57	6380	7.0	TKA 58	MY 90S4	98	
	298	35	4.69	5770	8.5	TKAF 58	MY 90S4	97	
	25	425	56.83	3310	0.95	TK 48	MY 90S4	92	
	29	365	48.95*	6360	1.10	TKF 48	MY 90S4	93	
	30	345	46.03*	6610	1.15	TKA 48	MY 90S4	94	
						TKAF 48	MY 90S4	93	
	35	295	39.61	7090	1.35	TK 48	MY 90S4	92	
	40	265	35.39	7090	1.50	TKF 48	MY 90S4	93	
	45	235	31.30	6960	1.70	TKA 48	MY 90S4	94	
	48	220	29.32	6890	1.80	TKAF 48	MY 90S4	93	
	54	194	25.91	6730	2.1				
	64	164	21.81	6510	2.4				
	72	147	19.58	6360	2.7				
	47	225	29.96	3420	0.90	TK 38	MY 90S4	88	
	56	188	24.99	3440	1.05	TKF 38	MY 90S4	89	
	60	175	23.36	3440	1.10	TKA 38	MY 90S4	90	
	69	152	20.19	3420	1.20	TKAF 38	MY 90S4	89	
	82	129	17.15	3370	1.40				
	91	115	15.31	3330	1.50				
	107	98	13.08	3260	1.70				
	115	91	12.14	3220	1.75				
	133	79	10.49	3140	2.0				
	157	67	8.91	3040	2.4				
	176	60	7.96	2970	2.6				
	206	51	6.80	2870	2.9				
	220	48	6.37	2830	3.0				
	261	40	5.36	2720	3.5				
	352	30	3.98	2520	4.2				
	<b>1.5</b>	0.21	60800	6747	190000	0.80	TK 188 / TRF98	MY 90L4	132
		0.24	53600	5991	190000	0.95	TKH 188 / TRF98	MY 90L4	132
0.26		47600	5358	190000	1.05				
0.29		42500	4817	190000	1.20				
0.32		38600	4370	190000	1.30				
0.39		33100	3609	190000	1.50	TK 188 / TRF98	MY 90L4	132	
0.46		28000	3062	190000	1.80	TKH 188 / TRF98	MY 90L4	132	
0.56		22800	2519	190000	2.2				
0.62		20400	2268	190000	2.5				
0.35		36700	4079	150000	0.85	TK 168 / TRF98	MY 90L4	132	
0.42		30500	3376	150000	1.05	TKH 168 / TRF98	MY 90L4	132	
0.51		24700	2755	150000	1.30				
0.65		20000	2182	150000	1.60	TK 168 / TRF98	MY 90L4	132	
0.83		15500	1704	150000	2.1	TKH 168 / TRF98	MY 90L4	132	
1.0		12900	1408	150000	2.5				
1.1		11800	1296	150000	2.7				
0.61		20500	2322	110800	0.90	TK 158 / TRF98	MY 90L4	132	
						TKF 158 / TRF98	MY 90L4	132	
						TKA 158 / TRF98	MY 90L4	132	
						TKAF 158 / TRF98	MY 90L4	132	
0.85	15200	1659	113500	1.20	TK 158 / TRF98	MY 90L4	132		
1.0	12400	1365	114600	1.45	TKF 158 / TRF98	MY 90L4	132		
1.2	11100	1229	115000	1.65	TKA 158 / TRF98	MY 90L4	132		
1.3	9840	1093	115300	1.85	TKAF 158 / TRF98	MY 90L4	132		

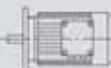

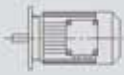

P <sub>1n</sub> [kW]	n <sub>2</sub> [r/min]	M <sub>2n</sub> [Nm]	i	Fr <sub>2</sub> [N]	fs			Page	
1.5	1.5	8480	942	115700	2.1	TK 158 / TRF98	MY 90L4	132	
	1.7	7630	854	115900	2.4	TKF 158 / TRF98	MY 90L4	132	
	2.5	5010	567	116300	3.6	TKA 158 / TRF98	MY 90L4	132	
	2.8	4460	504	116400	4.0	TKAF 158 / TRF98	MY 90L4	132	
	2.6	4830	536	82300	2.7	TK 128 / TRF88	MY 90L4	132	
	3.4	3800	418	82500	3.4	TKF 128 / TRF88	MY 90L4	132	
	3.8	3350	367	82600	3.9	TKA 128 / TRF88	MY 90L4	132	
							TKAF 128 / TRF88	MY 90L4	132
	0.80	16400	1757	73100	0.80	TK 128 / TRF78	MY 90L4	132	
	0.91	14300	1541	77300	0.90	TKF 128 / TRF78	MY 90L4	132	
	1.1	12500	1342	79500	1.05	TKA 128 / TRF78	MY 90L4	132	
	1.2	10900	1177	80300	1.20	TKAF 128 / TRF78	MY 90L4	132	
	1.4	9550	1025	80900	1.35				
	1.6	8360	899	81300	1.55				
	1.8	7240	790	81700	1.80				
	2.0	6520	704	81900	2.0				
	2.3	5620	610	82200	2.3				
	2.6	5080	549	82300	2.6				
	3.0	4370	477	82400	3.0				
	3.4	3870	418	82500	3.4				
	1.4	9520	1030	65000	0.85	TK 108 / TRF78	MY 90L4	132	
	1.6	8320	904	65000	0.95	TKF 108 / TRF78	MY 90L4	132	
	1.8	7390	793	65000	1.10	TKA 108 / TRF78	MY 90L4	132	
	2.0	6470	696	65000	1.25	TKAF 108 / TRF78	MY 90L4	132	
	2.3	5670	615	65000	1.40				
	2.7	4810	522	65000	1.65				
	3.1	4230	461	65000	1.90				
	3.5	3740	408	65000	2.1				
	3.9	3370	364	65000	2.4				
	4.4	2940	318	65000	2.7				
	2.5	5420	573	39400	0.80	TK 98 / TRF58	MY 90L4	132	
	2.8	4680	504	40000	0.90	TKF 98 / TRF58	MY 90L4	132	
	3.2	4050	437	40000	1.05	TKA 98 / TRF58	MY 90L4	132	
	3.7	3570	382	40000	1.20	TKAF 98 / TRF58	MY 90L4	132	
	4.1	3160	342	40000	1.35				
	4.6	2880	305	40000	1.50				
	5.5	2430	258	40000	1.75				
	6.1	2190	232	40000	1.95				
	7.1	1870	199	40000	2.3				
	4.3	3070	330	26800	0.90	TK 88 / TRF58	MY 90L4	132	
	4.8	2750	294	27200	1.00	TKF 88 / TRF58	MY 90L4	132	
	5.6	2360	250	27700	1.15	TKA 88 / TRF58	MY 90L4	132	
	6.0	2230	236	27800	1.20	TKAF 88 / TRF58	MY 90L4	132	
	7.0	1890	201	28200	1.45				
7.7	1720	183	28300	1.55					
4.9	2940	143.47*	65000	2.7	TK 108	MY 112M8	116		
5.8	2490	121.46	65000	3.2	TKF 108	MY 112M8	117		
6.2	2300	112.41*	65000	3.5	TKA 108	MY 112M8	118		
					TKAF 108	MY 112M8	117		
4.6	3140	153.21*	40000	1.35	TK 98	MY 112M8	112		
5.0	2870	140.28	40000	1.50	TKF 98	MY 112M8	113		
5.7	2540	123.93*	40000	1.70	TKA 98	MY 112M8	114		
					TKAF 98	MY 112M8	113		
5.2	2740	176.05*	40000	1.55	TK 98	MY 100M6	112		
6.0	2390	153.21*	40000	1.80	TKF 98	MY 100M6	113		
6.6	2180	140.28	40000	1.95	TKA 98	MY 100M6	114		
7.4	1930	123.93*	40000	2.2	TKAF 98	MY 100M6	113		

$P_{1n}$ [kW]	$n_2$ [r/min]	$M_{2n}$ [Nm]	$i$	$Fr_2$ [N]	$fs$			Page
1.5	8.0	1790	176.05*	40000	2.4	TK 98	MY 90L4	112
	9.2	1560	153.21*	40000	2.8	TKF 98	MY 90L4	113
	10	1430	140.28	40000	3.0	TKA 98	MY 90L4	114
	11	1260	123.93*	40000	3.4	TKAF 98	MY 90L4	113
	6.2	2290	147.32*	27800	1.20	TK 88	MY 100M6	108
	7.2	1980	126.91*	28100	1.35	TKF 88	MY 100M6	109
	7.9	1800	115.82	28200	1.50	TKA 88	MY 100M6	110
	9.0	1600	102.71*	28400	1.70	TKAF 88	MY 100M6	109
	8.1	1770	174.19	28300	1.55	TK 88	MY 90L4	108
	8.6	1670	164.34*	28300	1.60	TKF 88	MY 90L4	109
	9.6	1500	147.32*	28500	1.80	TKA 88	MY 90L4	110
	11	1290	126.91*	28600	2.1	TKAF 88	MY 90L4	109
	12	1180	115.82	28700	2.3			
	14	1040	102.71*	28800	2.6			
	16	880	86.34	28800	3.1			
	8.1	1770	113.56	13600	0.90	TK 78	MY 100M6	104
	9.5	1510	97.05	15700	1.05	TKF 78	MY 100M6	105
	10	1390	88.97	16400	1.10	TKA 78	MY 100M6	106
	12	1220	78.07	17400	1.30	TKAF 78	MY 100M6	105
	10	1370	135.28	16500	1.15	TK 78	MY 90L4	104
	11	1310	128.52	16900	1.20	TKF 78	MY 90L4	105
	12	1150	113.56	17700	1.35	TKA 78	MY 90L4	106
	15	990	97.05	18400	1.55	TKAF 78	MY 90L4	105
	16	900	88.97	18700	1.70			
	18	795	78.07	19000	1.95	TK 78	MY 90L4	104
	19	750	73.99	19100	2.1	TKF 78	MY 90L4	105
	22	660	64.75	19400	2.4	TKA 78	MY 90L4	106
	24	595	58.34	19500	2.6	TKAF 78	MY 90L4	105
	28	520	51.18	19700	3.0			
	31	460	45.16	19800	3.4			
	35	405	40.04	19800	3.8			
	16	910	90.04	9370	0.90	TK 68	MY 90L4	100
	18	775	76.37	10700	1.05	TKF 68	MY 90L4	101
	20	700	68.95	11300	1.15	TKA 68	MY 90L4	102
	23	615	60.66	11800	1.35	TKAF 68	MY 90L4	101
	25	580	57.28	12000	1.40			
	29	495	48.77	12400	1.65			
	32	450	44.32	12600	1.80	TK 68	MY 90L4	100
	37	390	38.39	12800	2.1	TKF 68	MY 90L4	101
	40	360	35.62	12900	2.3	TKA 68	MY 90L4	102
	47	305	30.22	13000	2.7	TKAF 68	MY 90L4	101
	52	275	27.28	13000	3.0			
	59	245	24.00	13000	3.3			
	23	620	60.81*	7480	0.95	TK 58	MY 90L4	96
25	585	57.42*	7770	1.05	TKF 58	MY 90L4	97	
29	495	48.89	8430	1.20	TKA 58	MY 90L4	98	
32	450	44.43	8650	1.35	TKAF 58	MY 90L4	97	
37	390	38.49	8920	1.55	TK 58	MY 90L4	96	
39	365	35.70	9040	1.65	TKF 58	MY 90L4	97	
47	310	30.28	9190	1.95	TKA 58	MY 90L4	98	
52	280	27.34	9010	2.2	TKAF 58	MY 90L4	97	
59	245	24.05	8780	2.5				
62	230	22.71	8670	2.6				
73	196	19.34	8360	2.9				

$P_{1n}$ [kW]	$n_2$ [r/min]	$M_{2n}$ [Nm]	$i$	$F_{r2}$ [N]	$f_s$			Page
<b>1.5</b>	36	400	39.61	5890	1.00	TK 48	MY 90L4	92
	40	360	35.39	6360	1.10	TKF 48	MY 90L4	93
	45	320	31.30	6310	1.25	TKA 48	MY 90L4	94
						TKAF 48	MY 90L4	93
	48	300	29.32	6270	1.35	TK 48	MY 90L4	92
	54	265	25.91	6190	1.50	TKF 48	MY 90L4	93
	65	220	21.81	6050	1.80	TKA 48	MY 90L4	94
	72	199	19.58	5950	2.0	TKAF 48	MY 90L4	93
	84	171	16.86	5800	2.2			
	89	161	15.86	5730	2.4			
	103	139	13.65	5560	2.6			
	116	124	12.19	5430	2.8			
	120	120	11.77	5340	2.3			
	60	235	23.36	2860	0.80	TK 38	MY 90L4	88
	70	205	20.19	2920	0.90	TKF 38	MY 90L4	89
	82	174	17.15	2940	1.05	TKA 38	MY 90L4	90
	92	156	15.31	2950	1.10	TKAF 38	MY 90L4	89
	108	133	13.08	2930	1.25			
	116	123	12.14	2920	1.30			
	134	107	10.49	2880	1.50			
	158	91	8.91	2820	1.75			
	177	81	7.96	2770	1.90			
	207	69	6.80	2700	2.2			
	221	65	6.37	2670	2.2			
263	55	5.36	2580	2.6				
354	40	3.98	2420	3.1				
<b>2.2</b>	0.32	57700	4370	190000	0.85	TK 188 / TRF98	MY 100M4	132
	0.50	36400	2818	190000	1.40	TKH 188 / TRF98	MY 100M4	132
	0.39	49000	3609	190000	1.00	TK 188 / TRF98	MY 100M4	132
	0.46	41600	3062	190000	1.20	TKH 188 / TRF98	MY 100M4	132
	0.56	34000	2519	190000	1.45			
	0.62	30400	2268	190000	1.65			
	0.69	27400	2054	190000	1.80			
	0.77	24200	1821	190000	2.1			
	0.88	21400	1605	190000	2.3			
	0.51	36700	2755	150000	0.85	TK 168 / TRF98	MY 100M4	132
	0.62	29500	2263	150000	1.10	TKH 168 / TRF98	MY 100M4	132
	0.65	29600	2182	150000	1.10	TK 168 / TRF98	MY 100M4	132
	0.83	23100	1704	150000	1.40	TKH 168 / TRF98	MY 100M4	132
	1.0	19100	1408	150000	1.65			
	1.1	17500	1296	150000	1.80			
	1.3	14600	1101	150000	2.2			
	1.5	12600	944	150000	2.5			
	0.85	22500	1659	109600	0.80	TK 158 / TRF98	MY 100M4	132
	1.0	18400	1365	112000	1.00	TKF 158 / TRF98	MY 100M4	132
	1.2	16500	1229	112900	1.10	TKA 158 / TRF98	MY 100M4	132
	1.3	14700	1093	113700	1.25	TKAF 158 / TRF98	MY 100M4	132
	1.5	12700	942	114500	1.40			
	1.7	11400	854	114900	1.60			
	1.9	9880	756	115300	1.80			
	2.6	7200	536	81700	1.80	TK 128 / TRF88	MY 100M4	132
	3.0	6300	473	82000	2.1	TKF 128 / TRF88	MY 100M4	132
	3.4	5670	418	82100	2.3	TKA 128 / TRF88	MY 100M4	132
	3.8	4970	367	82300	2.6	TKAF 128 / TRF88	MY 100M4	132
4.3	4460	330	82400	2.9				

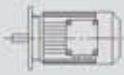

$P_{1n}$ [kW]	$n_2$ [r/min]	$M_{2n}$ [Nm]	$i$	$Fr_2$ [N]	$fs$			Page
2.2	1.4	14100	1025	77800	0.90	TK 128 / TRF78	MY 100M4	132
	1.6	12300	899	79500	1.05	TKF 128 / TRF78	MY 100M4	132
	1.8	10700	790	80400	1.20	TKA 128 / TRF78	MY 100M4	132
	2.0	9640	704	80800	1.35	TKAF 128 / TRF78	MY 100M4	132
	2.3	8330	610	81300	1.55			
	2.6	7510	549	81600	1.75			
	3.0	6490	477	81900	2.0			
	3.4	5720	418	82100	2.3			
	2.3	8390	615	65000	0.95	TK 108 / TRF78	MY 100M4	132
	2.7	7120	522	65000	1.10	TKF 108 / TRF78	MY 100M4	132
	3.1	6270	461	65000	1.30	TKA 108 / TRF78	MY 100M4	132
	3.5	5540	408	65000	1.45	TKAF 108 / TRF78	MY 100M4	132
	3.9	4980	364	65000	1.60			
	4.4	4350	318	65000	1.85			
	4.9	3910	286	65000	2.0			
	5.6	3430	251	65000	2.3			
	3.7	5260	382	39600	0.80	TK 98 / TRF58	MY 100M4	132
	4.1	4680	342	40000	0.90	TKF 98 / TRF58	MY 100M4	132
	4.6	4240	305	40000	1.00	TKA 98 / TRF58	MY 100M4	132
	5.5	3580	258	40000	1.20	TKAF 98 / TRF58	MY 100M4	132
	6.1	3220	232	40000	1.35			
	7.1	2760	199	40000	1.55			
	4.9	4310	143.47*	65000	1.85	TK 108	MY 132S8	116
	5.8	3650	121.46	65000	2.2	TKF 108	MY 132S8	117
	6.2	3370	112.41*	65000	2.4	TKA 108	MY 132S8	118
	7.0	3020	100.75	65000	2.7	TKAF 108	MY 132S8	117
	6.1	3420	153.21*	40000	1.25	TK 98	MY 112M6	112
	6.7	3140	140.28	40000	1.35	TKF 98	MY 112M6	113
	7.6	2770	123.93*	40000	1.55	TKA 98	MY 112M6	114
	8.9	2350	105.13	40000	1.85	TKAF 98	MY 112M6	113
	8.0	2620	176.05*	40000	1.65	TK 98	MY 100M4	112
	9.2	2280	153.21*	40000	1.90	TKF 98	MY 100M4	113
	10	2090	140.28	40000	2.1	TKA 98	MY 100M4	114
	11	1850	123.93*	40000	2.3	TKAF 98	MY 100M4	113
	13	1570	105.13	40000	2.8	TK 98	MY 100M4	112
15	1440	96.80	40000	3.0	TKF 98	MY 100M4	113	
					TKA 98	MY 100M4	114	
					TKAF 98	MY 100M4	113	
9.6	2200	147.32*	27900	1.25	TK 88	MY 100M4	108	
11	1890	126.91*	28200	1.45	TKF 88	MY 100M4	109	
12	1730	115.82	28300	1.55	TKA 88	MY 100M4	110	
					TKAF 88	MY 100M4	109	
14	1530	102.71*	28500	1.75	TK 88	MY 100M4	108	
16	1290	86.34	28600	2.1	TKF 88	MY 100M4	109	
18	1180	79.34	28700	2.3	TKA 88	MY 100M4	110	
20	1050	70.46	28800	2.6	TKAF 88	MY 100M4	109	
22	940	63.00*	28800	2.9				
12	1690	113.56	14300	0.90	TK 78	MY 100M4	104	
15	1450	97.05	16100	1.05	TKF 78	MY 100M4	105	
16	1330	88.97	16800	1.15	TKA 78	MY 100M4	106	
18	1160	78.07	17600	1.35	TKAF 78	MY 100M4	105	
19	1100	73.99	17900	1.40				
22	960	64.75	18400	1.60				
24	870	58.34	18800	1.80	TK 78	MY 100M4	104	
28	765	51.18	19100	2.0	TKF 78	MY 100M4	105	
31	675	45.16	19300	2.3	TKA 78	MY 100M4	106	
35	595	40.04	19500	2.6	TKAF 78	MY 100M4	105	

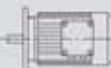
$P_{1n}$ [kW]	$n_2$ [r/min]	$M_{2n}$ [Nm]	$i$	$Fr_2$ [N]	$fs$			Page
<b>2.2</b>	40	525	35.20	19700	3.0	TK 78	MY 100M4	104
	46	460	30.89	19800	3.4	TKF 78	MY 100M4	105
	48	435	29.27	19800	3.6	TKA 78	MY 100M4	106
	55	380	25.62	19900	4.1	TKAF 78	MY 100M4	105
	23	900	60.66	9490	0.90	TK 68	MY 100M4	100
	25	850	57.28	10000	0.95	TKF 68	MY 100M4	101
	29	725	48.77	11100	1.15	TKA 68	MY 100M4	102
	32	660	44.32	11500	1.25	TKAF 68	MY 100M4	101
	37	570	38.39	12100	1.40			
	40	530	35.62	12300	1.55			
	47	450	30.22	12600	1.80			
	52	405	27.28	12800	2.0	TK 68	MY 100M4	100
	59	360	24.00	13000	2.2	TKF 68	MY 100M4	101
	62	340	22.66	13000	2.3	TKA 68	MY 100M4	102
	73	285	19.30	13000	2.6	TKAF 68	MY 100M4	101
	80	260	17.54	13000	2.8			
	93	225	15.19	13000	3.1			
	107	197	13.22	13000	3.4			
	113	186	12.48	13000	2.9			
	133	158	10.63	13000	3.2			
	146	144	9.66	13000	3.3			
	169	125	8.37	13000	3.5			
	194	109	7.28	12700	3.9			
	271	78	5.20	11700	4.5			
	32	660	44.43	5100	0.90	TK 58	MY 100M4	96
	37	575	38.49	7850	1.05	TKF 58	MY 100M4	97
	39	530	35.70	8180	1.15	TKA 58	MY 100M4	98
	47	450	30.28	8250	1.35	TKAF 58	MY 100M4	97
	52	405	27.34	8160	1.45	TK 58	MY 100M4	96
	59	360	24.05	8030	1.65	TKF 58	MY 100M4	97
	62	340	22.71	7970	1.75	TKA 58	MY 100M4	98
	73	290	19.34	7760	2.0	TKAF 58	MY 100M4	97
	80	260	17.57	7630	2.1			
	93	225	15.22	7430	2.4			
	106	197	13.25	7220	2.6			
	118	178	11.92	6890	2.3			
	125	168	11.26	6810	2.5			
	54	385	25.91	5260	1.05	TK 48	MY 100M4	92
	65	325	21.81	5260	1.25	TKF 48	MY 100M4	93
	72	290	19.58	5240	1.35	TKA 48	MY 100M4	94
						TKAF 48	MY 100M4	93
	84	250	16.86	5190	1.50	TK 48	MY 100M4	92
	89	235	15.86	5160	1.60	TKF 48	MY 100M4	93
	103	205	13.65	5070	1.75	TKA 48	MY 100M4	94
	116	182	12.19	4990	1.95	TKAF 48	MY 100M4	93
	120	175	11.77	4890	1.60			
	133	157	10.56	4810	1.80			
155	136	9.10	4690	2.1				
108	195	13.08	2370	0.85	TK 38	MY 100M4	88	
134	156	10.49	2430	1.00	TKF 38	MY 100M4	89	
158	133	8.91	2440	1.20	TKA 38	MY 100M4	90	
177	119	7.96	2430	1.30	TKAF 38	MY 100M4	89	
207	101	6.80	2410	1.50				
221	95	6.37	2400	1.55				
263	80	5.36	2350	1.75				
354	59	3.98	2250	2.1				

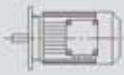

$P_{1n}$ [kW]	$n_2$ [r/min]	$M_{2n}$ [Nm]	$i$	$Fr_2$ [N]	$fs$			Page
<b>3.0</b>	0.50	50800	2818	190000	1.00	TK 188 / TRF98	MY 100L4	132
						TKH 188 / TRF98	MY 100L4	132
	0.46	57500	3062	190000	0.85	TK 188 / TRF98	MY 100L4	132
	0.56	47100	2519	190000	1.05	TKH 188 / TRF98	MY 100L4	132
	0.62	42200	2268	190000	1.20			
	0.68	38100	2054	190000	1.30			
	0.77	33600	1821	190000	1.50			
	0.87	29800	1605	190000	1.70			
	1.0	25500	1395	190000	1.95			
	1.2	22100	1196	190000	2.3			
0.82	31900	1704	150000	1.00	TK 168 / TRF98	MY 100L4	132	
0.99	26400	1408	150000	1.20	TKH 168 / TRF98	MY 100L4	132	
1.1	24300	1296	150000	1.30				
1.3	20300	1101	150000	1.55				
1.5	17500	944	150000	1.85				
1.7	15400	843	150000	2.1				
1.9	13900	757	150000	2.3				
1.1	22900	1229	109300	0.80	TK 158 / TRF98	MY 100L4	132	
1.3	20400	1093	110900	0.90	TKF 158 / TRF98	MY 100L4	132	
1.5	17600	942	112400	1.05	TKA 158 / TRF98	MY 100L4	132	
1.6	15800	854	113200	1.15	TKAF 158 / TRF98	MY 100L4	132	
1.9	13800	756	114000	1.30				
2.5	10500	567	115200	1.70				
2.8	9310	504	115500	1.95				
2.6	9980	536	80700	1.30	TK 128 / TRF88	MY 100L4	132	
3.0	8760	473	81200	1.50	TKF 128 / TRF88	MY 100L4	132	
3.4	7870	418	81500	1.65	TKA 128 / TRF88	MY 100L4	132	
3.8	6880	367	81800	1.90	TKAF 128 / TRF88	MY 100L4	132	
4.2	6170	330	82000	2.1				
4.9	5300	287	82200	2.5				
1.8	14800	790	76300	0.90	TK 128 / TRF78	MY 100L4	132	
2.0	13300	704	79000	1.00	TKF 128 / TRF78	MY 100L4	132	
2.3	11500	610	80000	1.15	TKA 128 / TRF78	MY 100L4	132	
2.6	10400	549	80500	1.25	TKAF 128 / TRF78	MY 100L4	132	
2.9	8970	477	81100	1.45				
3.4	7900	418	81500	1.65				
3.0	8660	461	65000	0.90	TK 108 / TRF78	MY 100L4	132	
3.4	7660	408	65000	1.05	TKF 108 / TRF78	MY 100L4	132	
3.9	6870	364	65000	1.15	TKA 108 / TRF78	MY 100L4	132	
4.4	6000	318	65000	1.35	TKAF 108 / TRF78	MY 100L4	132	
4.9	5400	286	65000	1.50				
5.6	4730	251	65000	1.70				
6.3	4170	222	65000	1.90				
7.1	3690	196	65000	2.2				
8.1	3300	174	65000	2.2				
9.1	2920	154	65000	2.5				
10	2650	140	65000	2.7				
5.4	4930	258	40000	0.85	TK 98 / TRF58	MY 100L4	132	
6.0	4440	232	40000	0.95	TKF 98 / TRF58	MY 100L4	132	
7.0	3810	199	40000	1.15	TKA 98 / TRF58	MY 100L4	132	
					TKAF 98 / TRF58	MY 100L4	132	
5.0	5710	143.47*	65000	1.40	TK 108	MY 132M8	116	
5.9	4830	121.46	65000	1.65	TKF 108	MY 132M8	117	
6.4	4470	112.41*	65000	1.80	TKA 108	MY 132M8	118	
7.2	4010	100.75	65000	2.0	TKAF 108	MY 132M8	117	
7.9	3620	90.96*	65000	2.2				

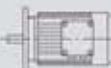

$P_{1n}$ [kW]	$n_2$ [r/min]	$M_{2n}$ [Nm]	$i$	$F_{r2}$ [N]	$f_s$			Page	
<b>3.0</b>	6.5	4370	143.47*	65000	1.85	TK 108	MY 132S6	116	
	7.7	3700	121.46	65000	2.2	TKF 108	MY 132S6	117	
	8.4	3430	112.41*	65000	2.3	TKA 108	MY 132S6	118	
	9.3	3070	100.75	65000	2.6	TKAF 108	MY 132S6	117	
	9.8	2940	143.47*	65000	2.7	TK 108	MY 100L4	116	
	12	2490	121.46	65000	3.2	TKF 108	MY 100L4	117	
							TKA 108	MY 100L4	118
							TKAF 108	MY 100L4	117
	7.6	3780	123.93*	40000	1.15	TK 98	MY 132S6	112	
	8.9	3200	105.13	40000	1.35	TKF 98	MY 132S6	113	
	9.7	2950	96.80	40000	1.45	TKA 98	MY 132S6	114	
	11	2640	86.52	40000	1.65	TKAF 98	MY 132S6	113	
	8.0	3600	176.05*	40000	1.20	TK 98	MY 100L4	112	
	9.1	3140	153.21*	40000	1.35	TKF 98	MY 100L4	113	
	10	2870	140.28	40000	1.50	TKA 98	MY 100L4	114	
	11	2540	123.93*	40000	1.70	TKAF 98	MY 100L4	113	
	13	2150	105.13	40000	2.0	TK 98	MY 100L4	112	
	14	1980	96.80	40000	2.2	TKF 98	MY 100L4	113	
	16	1770	86.52	40000	2.4	TKA 98	MY 100L4	114	
	18	1590	77.89*	40000	2.7	TKAF 98	MY 100L4	113	
	20	1440	70.54	40000	3.0				
	22	1280	62.55	40000	3.4				
	25	1160	56.55	40000	3.7				
	9.5	3010	147.32*	26900	0.90	TK 88	MY 100L4	108	
	11	2600	126.91*	27400	1.05	TKF 88	MY 100L4	109	
	12	2370	115.82	27700	1.15	TKA 88	MY 100L4	110	
	14	2100	102.71*	28000	1.30	TKAF 88	MY 100L4	109	
	16	1770	86.34	28300	1.55	TK 88	MY 100L4	108	
	18	1620	79.34	28400	1.65	TKF 88	MY 100L4	109	
	20	1440	70.46	28500	1.85	TKA 88	MY 100L4	110	
	22	1290	63.00*	28600	2.1	TKAF 88	MY 100L4	109	
	25	1160	56.64	28700	2.3				
	28	1010	49.16	28800	2.7				
	32	900	44.02	28800	2.9				
	38	745	36.52*	28400	3.4				
	16	1820	88.97	13100	0.85	TK 78	MY 100L4	104	
	18	1600	78.07	15000	0.95	TKF 78	MY 100L4	105	
	19	1510	73.99	15600	1.00	TKA 78	MY 100L4	106	
	22	1330	64.75	16800	1.15	TKAF 78	MY 100L4	105	
	24	1190	58.34	17500	1.30				
	27	1050	51.18	18100	1.50				
	31	920	45.16	18600	1.70	TK 78	MY 100L4	104	
	35	820	40.04	18900	1.90	TKF 78	MY 100L4	105	
	40	720	35.20	19200	2.2	TKA 78	MY 100L4	106	
	45	630	30.89	19400	2.5	TKAF 78	MY 100L4	105	
	32	910	44.32	9450	0.90	TK 68	MY 100L4	100	
36	785	38.39	10600	1.00	TKF 68	MY 100L4	101		
39	730	35.62	11100	1.15	TKA 68	MY 100L4	102		
46	620	30.22	11800	1.35	TKAF 68	MY 100L4	101		
51	560	27.28	12100	1.45					
58	490	24.00	12500	1.65					
62	465	22.66	12600	1.70	TK 68	MY 100L4	100		
73	395	19.30	12800	1.95	TKF 68	MY 100L4	101		
80	360	17.54	13000	2.1	TKA 68	MY 100L4	102		
92	310	15.19	13000	2.3	TKAF 68	MY 100L4	101		

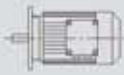
$P_{1n}$ [kW]	$n_2$ [r/min]	$M_{2n}$ [Nm]	$i$	$Fr_2$ [N]	$fs$			Page	
3.0	106	270	13.22	13000	2.5	TK 68	MY 100L4	100	
	112	255	12.48	13000	2.1	TKF 68	MY 100L4	101	
	132	220	10.63	13000	2.3	TKA 68	MY 100L4	102	
	145	198	9.66	13000	2.4	TKAF 68	MY 100L4	101	
	46	620	30.28	7180	0.95	TK 58	MY 100L4	96	
	51	560	27.34	7190	1.05	TKF 58	MY 100L4	97	
	58	490	24.05	7180	1.20	TKA 58	MY 100L4	98	
							TKAF 58	MY 100L4	97
	62	465	22.71	7160	1.30	TK 58	MY 100L4	96	
	72	395	19.34	7080	1.45	TKF 58	MY 100L4	97	
	80	360	17.57	7020	1.55	TKA 58	MY 100L4	98	
	92	310	15.22	6890	1.70	TKAF 58	MY 100L4	97	
	106	270	13.25	6750	1.90				
	117	245	11.92	6420	1.70				
	124	230	11.26	6370	1.80				
	146	196	9.59	6200	2.1				
	161	178	8.71	6090	2.2				
	186	154	7.55	5920	2.4				
	213	134	6.57	5750	2.6				
	298	96	4.69	5320	3.1				
	72	400	19.58	4430	1.00	TK 48	MY 100L4	92	
	83	345	16.86	4490	1.10	TKF 48	MY 100L4	93	
	88	325	15.86	4500	1.15	TKA 48	MY 100L4	94	
							TKAF 48	MY 100L4	93
	103	280	13.65	4510	1.30	TK 48	MY 100L4	92	
	115	250	12.19	4490	1.40	TKF 48	MY 100L4	93	
	119	240	11.77	4370	1.15	TKA 48	MY 100L4	94	
	133	215	10.56	4350	1.30	TKAF 48	MY 100L4	93	
	154	186	9.10	4290	1.50				
	164	175	8.56	4270	1.55				
	190	151	7.36	4190	1.65				
	213	135	6.58	4120	1.80				
	241	119	5.81	4030	1.95				
	302	95	4.64	3860	2.2				
	157	182	8.91	2000	0.90	TK 38	MY 100L4	88	
	176	163	7.96	2040	0.95	TKF 38	MY 100L4	89	
	206	139	6.80	2080	1.10	TKA 38	MY 100L4	90	
	220	130	6.37	2080	1.10	TKAF 38	MY 100L4	89	
	261	110	5.36	2090	1.30				
	352	81	3.98	2050	1.55				
	4.0	1.7	20100	835	190000	2.5	TK 188 / TRF108	MY 112M4	132
		2.7	12600	520	190000	4.0	TKH 188 / TRF108	MY 112M4	132
		0.56	62200	2519	190000	0.80	TK 188 / TRF98	MY 112M4	132
		0.63	55900	2268	190000	0.90	TKH 188 / TRF98	MY 112M4	132
0.69		50500	2054	190000	1.00				
0.78		44600	1821	190000	1.10				
0.88		39400	1605	190000	1.25				
1.0		33900	1395	190000	1.50				
1.2		29300	1196	190000	1.70				
1.4		25600	1046	190000	1.95				
1.5		23100	945	190000	2.2				
1.0		34900	1408	150000	0.90	TK 168 / TRF98	MY 112M4	132	
1.1		32100	1296	150000	1.00	TKH 168 / TRF98	MY 112M4	132	
1.3		26900	1101	150000	1.20				
1.5		23200	944	150000	1.40				
1.7		20500	843	150000	1.55				

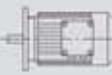

$P_{1n}$ [kW]	$n_2$ [r/min]	$M_{2n}$ [Nm]	$i$	$F_{r2}$ [N]	$f_s$			Page
<b>4.0</b>	1.9	18500	757	150000	1.75	TK 168 / TRF98	MY 112M4	132
	2.2	15500	632	150000	2.1	TKH 168 / TRF98	MY 112M4	132
	1.7	21000	854	110600	0.85	TK 158 / TRF98	MY 112M4	132
	1.9	18300	756	112000	1.00	TKF 158 / TRF98	MY 112M4	132
	2.5	13900	567	114000	1.30	TKA 158 / TRF98	MY 112M4	132
	2.8	12300	504	114600	1.45	TKAF 158 / TRF98	MY 112M4	132
	3.3	10500	434	115100	1.70			
	2.6	13200	536	79100	1.00	TK 128 / TRF88	MY 112M4	132
	3.0	11600	473	79900	1.10	TKF 128 / TRF88	MY 112M4	132
	3.4	10400	418	80500	1.25	TKA 128 / TRF88	MY 112M4	132
	3.9	9090	367	81100	1.45	TKAF 128 / TRF88	MY 112M4	132
	4.3	8160	330	81400	1.60			
	5.0	7020	287	81800	1.85			
	5.6	6210	253	82000	2.1			
	2.3	15200	610	75600	0.85	TK 128 / TRF78	MY 112M4	132
	2.6	13700	549	78600	0.95	TKF 128 / TRF78	MY 112M4	132
	3.0	11800	477	79800	1.10	TKA 128 / TRF78	MY 112M4	132
	3.4	10400	418	80500	1.25	TKAF 128 / TRF78	MY 112M4	132
	3.9	9050	364	65000	0.90	TK 108 / TRF78	MY 112M4	132
	4.5	7910	318	65000	1.00	TKF 108 / TRF78	MY 112M4	132
	5.0	7120	286	65000	1.10	TKA 108 / TRF78	MY 112M4	132
	5.7	6240	251	65000	1.30	TKAF 108 / TRF78	MY 112M4	132
	6.4	5500	222	65000	1.45			
	7.2	4870	196	65000	1.65			
	8.2	4360	174	65000	1.65			
	9.2	3860	154	65000	1.85			
	10	3500	140	65000	2.1			
	7.1	5020	199	39900	0.85	TK 98 / TRF58	MY 112M4	132
						TKF 98 / TRF58	MY 112M4	132
						TKA 98 / TRF58	MY 112M4	132
						TKAF 98 / TRF58	MY 112M4	132
	5.3	7220	136.14	81700	1.80	TK 128	MY 132ML8	120
	5.9	6500	122.48	81900	2.0	TKF 128	MY 132ML8	121
	6.5	5850	110.18	82100	2.2	TKA 128	MY 132ML8	122
						TKAF 128	MY 132ML8	121
	6.6	5810	146.07	82100	2.2	TK 128	MY 132M6	120
	7.0	5420	136.14	82200	2.4	TKF 128	MY 132M6	121
	7.8	4870	122.48	82300	2.7	TKA 128	MY 132M6	122
	8.7	4380	110.18	82400	3.0	TKAF 128	MY 132M6	121
	6.4	5960	112.41*	65000	1.35	TK 108	MY 132ML8	116
	7.2	5340	100.75	65000	1.50	TKF 108	MY 132ML8	117
	7.9	4830	90.96*	65000	1.65	TKA 108	MY 132ML8	118
	8.7	4380	82.61	65000	1.85	TKAF 108	MY 132ML8	117
	6.7	5710	143.47*	65000	1.40	TK 108	MY 132M6	116
	7.9	4830	121.46	65000	1.65	TKF 108	MY 132M6	117
	8.5	4470	112.41*	65000	1.80	TKA 108	MY 132M6	118
	9.5	4010	100.75	65000	2.0	TKAF 108	MY 132M6	117
	11	3620	90.96*	65000	2.2			
	9.9	3860	143.47*	65000	2.1	TK 108	MY 112M4	116
	12	3270	121.46	65000	2.5	TKF 108	MY 112M4	117
13	3020	112.41*	65000	2.7	TKA 108	MY 112M4	118	
14	2710	100.75	65000	3.0	TKAF 108	MY 112M4	117	
16	2450	90.96*	65000	3.3				
17	2220	82.61	65000	3.6				
19	1970	73.30	65000	4.1				

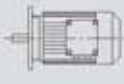

$P_{1n}$ [kW]	$n_2$ [r/min]	$M_{2n}$ [Nm]	$i$	$Fr_2$ [N]	$fs$			Page
<b>4.0</b>	9.3	4120	153.21*	40000	1.05	TK 98	MY 112M4	112
	10	3770	140.28	40000	1.15	TKF 98	MY 112M4	113
	11	3330	123.93*	40000	1.30	TKA 98	MY 112M4	114
						TKAF 98	MY 112M4	113
	14	2830	105.13	40000	1.50	TK 98	MY 112M4	112
	15	2600	96.80	40000	1.65	TKF 98	MY 112M4	113
	16	2330	86.52	40000	1.85	TKA 98	MY 112M4	114
	18	2100	77.89*	40000	2.1	TKAF 98	MY 112M4	113
	20	1900	70.54	40000	2.3			
	12	3120	115.82	26700	0.85	TK 88	MY 112M4	108
	14	2760	102.71*	27200	1.00	TKF 88	MY 112M4	109
	16	2320	86.34	27700	1.15	TKA 88	MY 112M4	110
	18	2130	79.34	27900	1.25	TKAF 88	MY 112M4	109
	20	1900	70.46	28200	1.40	TK 88	MY 112M4	108
	23	1690	63.00*	28300	1.60	TKF 88	MY 112M4	109
	25	1520	56.64	28500	1.75	TKA 88	MY 112M4	110
	29	1320	49.16	28600	2.0	TKAF 88	MY 112M4	109
	32	1180	44.02	28300	2.2			
	39	980	36.52*	27300	2.5			
	22	1740	64.75	13900	0.90	TK 78	MY 112M4	104
	24	1570	58.34	15200	1.00	TKF 78	MY 112M4	105
	28	1380	51.18	16500	1.15	TKA 78	MY 112M4	106
	31	1210	45.16	17400	1.30	TKAF 78	MY 112M4	105
	35	1080	40.04	18000	1.45			
	37	1030	38.39	18200	1.45			
	40	950	35.20	18500	1.65	TK 78	MY 112M4	104
	46	830	30.89	18900	1.85	TKF 78	MY 112M4	105
	49	785	29.27	19000	1.95	TKA 78	MY 112M4	106
	55	690	25.62	19300	2.3	TKAF 78	MY 112M4	105
	62	620	23.08	19500	2.5			
	70	545	20.25	19600	2.8			
	47	810	30.22	10400	1.00	TK 68	MY 112M4	100
	52	735	27.28	11000	1.10	TKF 68	MY 112M4	101
	59	645	24.00	11600	1.25	TKA 68	MY 112M4	102
	63	610	22.66	11800	1.30	TKAF 68	MY 112M4	101
	74	520	19.30	12300	1.45	TK 68	MY 112M4	100
	81	470	17.54	12500	1.55	TKF 68	MY 112M4	101
	94	410	15.19	12800	1.70	TKA 68	MY 112M4	102
	107	355	13.22	13000	1.90	TKAF 68	MY 112M4	101
	114	335	12.48	13000	1.60			
	134	285	10.63	13000	1.75			
	147	260	9.66	12900	1.85			
	170	225	8.37	12500	1.95			
	195	196	7.28	12100	2.1			
	273	140	5.20	11200	2.5			
	59	645	24.05	6120	0.95	TK 58	MY 112M4	96
	63	610	22.71	6160	1.00	TKF 58	MY 112M4	97
	73	520	19.34	6220	1.10	TKA 58	MY 112M4	98
81	475	17.57	6230	1.15	TKAF 58	MY 112M4	97	
93	410	15.22	6210	1.30				
107	355	13.25	6150	1.45				
119	320	11.92	5810	1.30				
126	305	11.26	5790	1.35				
148	260	9.59	5700	1.55				

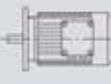
$P_{1n}$ [kW]	$n_2$ [r/min]	$M_{2n}$ [Nm]	$i$	$Fr_2$ [N]	$fs$			Page
<b>4.0</b>	163	235	8.71	5640	1.65	TK 58	MY 112M4	96
	188	205	7.55	5530	1.80	TKF 58	MY 112M4	97
	216	177	6.57	5400	1.95	TKA 58	MY 112M4	98
	303	126	4.69	5070	2.4	TKAF 58	MY 112M4	97
<b>5.5</b>	0.79	61300	1821	190000	0.80	TK 188 / TRF98	MY 132S4	132
	0.89	54200	1605	190000	0.90	TKH 188 / TRF98	MY 132S4	132
	1.0	46700	1395	190000	1.05			
	1.2	40300	1196	190000	1.25			
	1.4	35200	1046	190000	1.40			
	1.5	31700	945	190000	1.60			
	1.9	24800	738	190000	2.0			
	2.3	20800	621	190000	2.4			
	1.3	37100	1101	150000	0.85	TK 168 / TRF98	MY 132S4	132
	1.5	31900	944	150000	1.00	TKH 168 / TRF98	MY 132S4	132
	1.7	28200	843	150000	1.15			
	1.9	25400	757	150000	1.25			
	2.3	21300	632	150000	1.50			
	2.6	18700	561	150000	1.70			
	3.0	16200	481	150000	2.0			
	3.4	14100	423	150000	2.3			
	2.2	22000	661	109900	0.80	TK 158 / TRF98	MY 132S4	132
	2.5	19100	567	111600	0.95	TKF 158 / TRF98	MY 132S4	132
	2.8	17000	504	112700	1.05	TKA 158 / TRF98	MY 132S4	132
	3.3	14500	434	113800	1.25	TKAF 158 / TRF98	MY 132S4	132
	3.8	12600	379	114500	1.45			
	4.3	11100	333	115000	1.60			
	3.4	14300	418	77400	0.90	TK 128 / TRF88	MY 132S4	132
	3.9	12500	367	79500	1.05	TKF 128 / TRF88	MY 132S4	132
	4.3	11200	330	80100	1.15	TKA 128 / TRF88	MY 132S4	132
	5.0	9650	287	80800	1.35	TKAF 128 / TRF88	MY 132S4	132
	5.6	8540	253	81300	1.50			
	6.7	7170	213	81700	1.80			
	7.1	6830	200	81800	1.75			
	8.6	5660	166	82100	2.1			
	9.8	4990	147	82300	2.4			
	6.5	7540	222	65000	1.05	TK 108 / TRF78	MY 132S4	132
	7.3	6680	196	65000	1.20	TKF 108 / TRF78	MY 132S4	132
	8.2	5970	174	65000	1.20	TKA 108 / TRF78	MY 132S4	132
	9.3	5280	154	65000	1.35	TKAF 108 / TRF78	MY 132S4	132
	10	4800	140	65000	1.50			
	4.7	11100	150.41	115000	1.60	TK 158	MY 160M8	124
	5.8	9050	122.39	115500	2.0	TKF 158	MY 160M8	125
	7.1	7410	100.22	115900	2.4	TKA 158	MY 160M8	126
	7.8	6780	91.65	116000	2.7	TKAF 158	MY 160M8	125
	5.2	10100	136.14	80700	1.30	TK 128	MY 160M8	120
	5.8	9060	122.48	81100	1.45	TKF 128	MY 160M8	121
6.4	8150	110.18	81400	1.60	TKA 128	MY 160M8	122	
7.9	6650	89.89	81900	1.95	TKAF 128	MY 160M8	121	
7.0	7450	136.14	81600	1.75	TK 128	MY 132ML6	120	
7.8	6700	122.48	81900	1.95	TKF 128	MY 132ML6	121	
8.7	6030	110.18	82100	2.2	TKA 128	MY 132ML6	122	
11	4920	89.89	82300	2.6	TKAF 128	MY 132ML6	121	
8.5	6150	112.41*	65000	1.30	TK 108	MY 132ML6	116	
9.5	5510	100.75	65000	1.45	TKF 108	MY 132ML6	117	
11	4980	90.96*	65000	1.60	TKA 108	MY 132ML6	118	
12	4520	82.61	65000	1.75	TKAF 108	MY 132ML6	117	

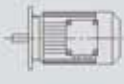

P <sub>1n</sub> [kW]	n <sub>2</sub> [r/min]	M <sub>2n</sub> [Nm]	i	Fr <sub>2</sub> [N]	fs			Page
5.5	10	5270	143.47*	65000	1.50	TK 108	MY 132S4	116
	12	4460	121.46	65000	1.80	TKF 108	MY 132S4	117
	13	4130	112.41*	65000	1.95	TKA 108	MY 132S4	118
	14	3700	100.75	65000	2.2	TKAF 108	MY 132S4	117
	16	3340	90.96*	65000	2.4			
	17	3030	82.61	65000	2.6			
	12	4550	123.93*	40000	0.95	TK 98	MY 132S4	112
	14	3860	105.13	40000	1.10	TKF 98	MY 132S4	113
	15	3560	96.80	40000	1.20	TKA 98	MY 132S4	114
	17	3180	86.52	40000	1.35	TKAF 98	MY 132S4	113
	18	2860	77.89*	40000	1.50	TK 98	MY 132S4	112
	20	2590	70.54	40000	1.65	TKF 98	MY 132S4	113
	23	2300	62.55	40000	1.85	TKA 98	MY 132S4	114
	25	2080	56.55	39700	2.1	TKAF 98	MY 132S4	113
	30	1760	47.93*	38600	2.4			
	17	3170	86.34	26600	0.85	TK 88	MY 132S4	108
	18	2910	79.34	27000	0.95	TKF 88	MY 132S4	109
	20	2590	70.46	27400	1.05	TKA 88	MY 132S4	110
	23	2310	63.00*	27500	1.15	TKAF 88	MY 132S4	109
	25	2080	56.64	27300	1.30			
	29	1810	49.16	26900	1.50	TK 88	MY 132S4	108
	32	1620	44.02	26500	1.60	TKF 88	MY 132S4	109
	39	1340	36.52*	25800	1.85	TKA 88	MY 132S4	110
	46	1150	31.39	25200	2.3	TKAF 88	MY 132S4	109
	51	1020	27.88	24700	2.5			
	32	1660	45.16	14600	0.95	TK 78	MY 132S4	104
	36	1470	40.04	15900	1.05	TKF 78	MY 132S4	105
	46	1130	30.89	17800	1.35	TKA 78	MY 132S4	106
	49	1070	29.27	18000	1.45	TKAF 78	MY 132S4	105
	56	940	25.62	18500	1.65			
62	850	23.08	18800	1.85	TK 78	MY 132S4	104	
71	745	20.25	19100	2.0	TKF 78	MY 132S4	105	
80	655	17.87	19400	2.2	TKA 78	MY 132S4	106	
90	580	15.84	19200	2.4	TKAF 78	MY 132S4	105	
106	495	13.52	18600	2.7				
116	455	12.36	17900	2.2				
132	400	10.84	17400	2.5				
60	880	24.00	9720	0.90	TK 68	MY 132S4	100	
63	830	22.66	10200	0.95	TKF 68	MY 132S4	101	
74	710	19.30	11200	1.05	TKA 68	MY 132S4	102	
82	645	17.54	11600	1.15	TKAF 68	MY 132S4	101	
94	560	15.19	12100	1.25				
108	485	13.22	12500	1.40				
115	460	12.48	12600	1.15	TK 68	MY 132S4	100	
135	390	10.63	12400	1.30	TKF 68	MY 132S4	101	
148	355	9.66	12200	1.35	TKA 68	MY 132S4	102	
171	305	8.37	11900	1.45	TKAF 68	MY 132S4	101	
196	265	7.28	11600	1.55				
275	191	5.20	10800	1.85				
7.5	1.7	38200	835	190000	1.30	TK 188 / TRF108	MY 132M4	132
	2.0	33200	729	190000	1.50	TKH 188 / TRF108	MY 132M4	132
	2.3	28300	622	190000	1.75			
	1.2	55200	1196	190000	0.90	TK 188 / TRF98	MY 132M4	132
	1.4	48200	1046	190000	1.05	TKH 188 / TRF98	MY 132M4	132
	1.5	43500	945	190000	1.15			
	1.9	34000	738	190000	1.45			

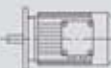

$P_{1n}$ [kW]	$n_2$ [r/min]	$M_{2n}$ [Nm]	$i$	$F_{r2}$ [N]	$f_s$			Page	
7.5	2.3	28600	621	190000	1.75	TK	188 / TRF98	MY 132M4	132
	2.7	24200	527	190000	2.1	TKH	188 / TRF98	MY 132M4	132
	1.7	38700	843	150000	0.85	TK	168 / TRF98	MY 132M4	132
	1.9	34900	757	150000	0.90	TKH	168 / TRF98	MY 132M4	132
	2.3	29200	632	150000	1.10				
	2.6	25600	561	150000	1.25				
	3.0	22200	481	150000	1.45				
	3.4	19400	423	150000	1.65				
	3.9	16900	369	150000	1.90				
	3.3	19900	434	111200	0.90	TK	158 / TRF98	MY 132M4	132
	3.8	17400	379	112500	1.05	TKF	158 / TRF98	MY 132M4	132
	4.3	15300	333	113500	1.20	TKA	158 / TRF98	MY 132M4	132
	4.9	13300	291	114200	1.35	TKAF	158 / TRF98	MY 132M4	132
	4.3	15300	330	75300	0.85	TK	128 / TRF88	MY 132M4	132
	5.0	13200	287	79100	1.00	TKF	128 / TRF88	MY 132M4	132
	5.6	11700	253	79900	1.10	TKA	128 / TRF88	MY 132M4	132
	6.7	9830	213	80800	1.30	TKAF	128 / TRF88	MY 132M4	132
	7.1	9360	200	80900	1.30				
	8.6	7750	166	81500	1.55				
	9.8	6840	147	81800	1.75				
	4.4	16400	164.50	150000	1.95	TK	168	MY 160L8	128
	5.3	13400	134.99	150000	2.4	TKH	168	MY 160L8	129
	5.8	12300	164.50	150000	2.6	TK	168	MY 160M6	128
	7.1	10100	134.99	150000	3.2	TKH	168	MY 160M6	129
	6.4	11200	150.41	114900	1.60	TK	158	MY 160M6	124
	7.8	9130	122.39	115500	1.95	TKF	158	MY 160M6	125
	9.6	7480	100.22	115900	2.4	TKA	158	MY 160M6	126
	10	6840	91.65	116000	2.6	TKAF	158	MY 160M6	125
	12	5950	79.75	116200	3.0				
	7.0	10200	136.14	80600	1.30	TK	128	MY 160M6	120
	7.8	9140	122.48	81000	1.40	TKF	128	MY 160M6	121
	8.7	8220	110.18	81400	1.60	TKA	128	MY 160M6	122
	11	6710	89.89	81900	1.95	TKAF	128	MY 160M6	121
	9.8	7320	146.07	81700	1.80	TK	128	MY 132M4	120
	11	6820	136.14	81800	1.90	TKF	128	MY 132M4	121
	12	6130	122.48	82000	2.1	TKA	128	MY 132M4	122
	13	5520	110.18	82200	2.4	TKAF	128	MY 132M4	121
	16	4500	89.89	82400	2.9				
	17	4110	81.98	82500	3.2				
	20	3550	70.95*	82600	3.7				
	10	7190	143.47*	65000	1.10	TK	108	MY 132M4	116
	12	6080	121.46	65000	1.30	TKF	108	MY 132M4	117
13	5630	112.41*	65000	1.40	TKA	108	MY 132M4	118	
					TKAF	108	MY 132M4	117	
14	5050	100.75	65000	1.60	TK	108	MY 132M4	116	
16	4560	90.96*	64200	1.75	TKF	108	MY 132M4	117	
17	4140	82.61	63200	1.95	TKA	108	MY 132M4	118	
20	3670	73.30	61900	2.2	TKAF	108	MY 132M4	117	
22	3330	66.52*	60900	2.4					
25	2860	57.17*	59100	2.8					
29	2500	49.90	57500	3.1					
34	2120	42.33*	55500	3.5					
39	1850	37.00*	53800	3.9					

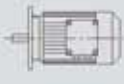
$P_{1n}$ [kW]	$n_2$ [r/min]	$M_{2n}$ [Nm]	$i$	$Fr_2$ [N]	$fs$			Page	
<b>7.5</b>	15	4850	96.80	38300	0.90	TK 98	MY 132M4	112	
	17	4330	86.52	38300	1.00	TKF 98	MY 132M4	113	
	18	3900	77.89*	38100	1.10	TKA 98	MY 132M4	114	
	20	3530	70.54	37900	1.20	TKAF 98	MY 132M4	113	
	23	3130	62.55	37500	1.35				
	25	2830	56.55	37100	1.50	TK 98	MY 132M4	112	
	30	2400	47.93*	36400	1.80	TKF 98	MY 132M4	113	
	34	2100	41.87	35600	2.1	TKA 98	MY 132M4	114	
	37	1920	38.30	35100	2.2	TKAF 98	MY 132M4	113	
	42	1710	34.23	34400	2.5				
	23	3160	63.00*	24100	0.85	TK 88	MY 132M4	108	
	25	2840	56.64	24200	0.95	TKF 88	MY 132M4	109	
	29	2460	49.16	24200	1.10	TKA 88	MY 132M4	110	
	32	2200	44.02	24200	1.20	TKAF 88	MY 132M4	109	
	39	1830	36.52*	23900	1.35				
	46	1570	31.39	23500	1.70	TK 88	MY 132M4	108	
	51	1400	27.88	23200	1.85	TKF 88	MY 132M4	109	
	57	1250	24.92	22800	2.0	TKA 88	MY 132M4	110	
	64	1120	22.41	22500	2.1	TKAF 88	MY 132M4	109	
	74	970	19.45	21900	2.4				
	82	870	17.42	21500	2.5				
	89	800	16.00	20600	2.3				
	99	725	14.45	20700	2.9				
	46	1550	30.89	15400	1.00	TK 78	MY 132M4	104	
	49	1470	29.27	16000	1.05	TKF 78	MY 132M4	105	
	56	1280	25.62	17000	1.20	TKA 78	MY 132M4	106	
	62	1160	23.08	17700	1.35	TKAF 78	MY 132M4	105	
	71	1010	20.25	18300	1.50				
	80	890	17.87	18600	1.60	TK 78	MY 132M4	104	
	90	795	15.84	18200	1.75	TKF 78	MY 132M4	105	
	106	675	13.52	17800	2.0	TKA 78	MY 132M4	106	
	116	620	12.36	17000	1.60	TKAF 78	MY 132M4	105	
	132	545	10.84	16700	1.80				
	150	480	9.56	16300	1.95				
	169	425	8.48	15900	2.1				
	198	365	7.24	15400	2.3				
	<b>9.2</b>	1.7	46700	835	190000	1.05	TK 188 / TRF108	MY 132ML4	132
		2.0	40600	729	190000	1.25	TKH 188 / TRF108	MY 132ML4	132
		2.3	34600	622	190000	1.45			
		2.8	29400	520	190000	1.70			
		3.2	25600	454	190000	1.95			
		1.4	58900	1046	190000	0.85	TK 188 / TRF98	MY 132ML4	132
		1.5	53200	945	190000	0.95	TKH 188 / TRF98	MY 132ML4	132
		1.9	41600	738	190000	1.20			
		2.3	34900	621	190000	1.45			
2.7		29500	527	190000	1.70				
4.5		18000	318	150000	1.80	TK 168 / TRF108	MY 132ML4	132	
5.2		15600	278	150000	2.1	TKH 168 / TRF108	MY 132ML4	132	
5.9		13500	244	150000	2.4				
6.8		11800	213	150000	2.7				
7.0		11500	206	150000	2.8				
2.3		35600	632	150000	0.90	TK 168 / TRF98	MY 132ML4	132	
2.6		31400	561	150000	1.00	TKH 168 / TRF98	MY 132ML4	132	
3.0		27100	481	150000	1.20				
3.4		23700	423	150000	1.35				
3.9		20700	369	150000	1.55				

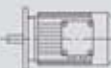

$P_{1n}$ [kW]	$n_2$ [r/min]	$M_{2n}$ [Nm]	$i$	$F_{R2}$ [N]	$f_s$			Page	
<b>9.2</b>	3.7	21300	385	110400	0.85	TK 158 / TRF108	MY 132ML4	132	
	4.4	17900	325	112300	1.00	TKF 158 / TRF108	MY 132ML4	132	
	4.8	16600	299	112800	1.10	TKA 158 / TRF108	MY 132ML4	132	
	5.7	14100	253	114000	1.30	TKAF 158 / TRF108	MY 132ML4	132	
	6.2	12600	230	114500	1.40				
	3.8	21200	379	110400	0.85	TK 158 / TRF98	MY 132ML4	132	
	4.3	18700	333	111800	0.95	TKF 158 / TRF98	MY 132ML4	132	
	5.0	16300	291	113000	1.10	TKA 158 / TRF98	MY 132ML4	132	
							TKAF 158 / TRF98	MY 132ML4	132
	5.7	14300	253	77400	0.90	TK 128 / TRF88	MY 132ML4	132	
	6.8	12000	213	79700	1.10	TKF 128 / TRF88	MY 132ML4	132	
	7.2	11400	200	80000	1.05	TKA 128 / TRF88	MY 132ML4	132	
	8.7	9460	166	80900	1.25	TKAF 128 / TRF88	MY 132ML4	132	
	9.8	8350	147	81300	1.45				
	11	8310	136.14	81300	1.55	TK 128	MY 132ML4	120	
	12	7470	122.48	81600	1.75	TKF 128	MY 132ML4	121	
	13	6720	110.18	81900	1.95	TKA 128	MY 132ML4	122	
	16	5480	89.89	82200	2.4	TKAF 128	MY 132ML4	121	
	18	5000	81.98	82300	2.6				
	13	6860	112.41*	62400	1.15	TK 108	MY 132ML4	116	
	14	6150	100.75	61800	1.30	TKF 108	MY 132ML4	117	
	16	5550	90.96*	61100	1.45	TKA 108	MY 132ML4	118	
						TKAF 108	MY 132ML4	117	
	17	5040	82.61	60400	1.60	TK 108	MY 132ML4	116	
	20	4470	73.30	59400	1.80	TKF 108	MY 132ML4	117	
	22	4060	66.52*	58600	1.95	TKA 108	MY 132ML4	118	
	25	3490	57.17*	57100	2.3	TKAF 108	MY 132ML4	117	
	29	3040	49.90	55700	2.6				
	34	2580	42.33*	54000	2.9				
	18	4750	77.89*	35100	0.90	TK 98	MY 132ML4	112	
	20	4300	70.54	35100	1.00	TKF 98	MY 132ML4	113	
	23	3820	62.55	35100	1.15	TKA 98	MY 132ML4	114	
	25	3450	56.55	34900	1.25	TKAF 98	MY 132ML4	113	
	30	2920	47.93*	34400	1.45	TK 98	MY 132ML4	112	
	34	2550	41.87	34000	1.70	TKF 98	MY 132ML4	113	
	38	2340	38.30	33600	1.85	TKA 98	MY 132ML4	114	
	42	2090	34.23	33100	2.1	TKAF 98	MY 132ML4	113	
	47	1880	30.82	32500	2.3				
	52	1700	27.91	32000	2.5				
	58	1510	24.75	31300	2.9				
	29	3000	49.16	22000	0.90	TK 88	MY 132ML4	108	
	33	2690	44.02	22200	0.95	TKF 88	MY 132ML4	109	
	39	2230	36.52*	22200	1.10	TKA 88	MY 132ML4	110	
	46	1910	31.39	22100	1.40	TKAF 88	MY 132ML4	109	
	52	1700	27.88	21900	1.55	TK 88	MY 132ML4	108	
	58	1520	24.92	21700	1.65	TKF 88	MY 132ML4	109	
	64	1370	22.41	21400	1.70	TKA 88	MY 132ML4	110	
	74	1190	19.45	21000	1.95	TKAF 88	MY 132ML4	109	
	83	1060	17.42	20700	2.1				
	90	980	16.00	19700	1.85				
100	880	14.45	20000	2.4					
115	765	12.56	19500	2.6					
129	680	11.17	18600	2.2					
144	610	10.00	18200	2.5					

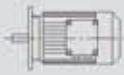

$P_{1n}$ [kW]	$n_2$ [r/min]	$M_{2n}$ [Nm]	$i$	$Fr_2$ [N]	$fs$			Page
9.2	62	1410	23.08	16300	1.10	TK 78	MY 132ML4	104
	71	1240	20.25	17300	1.20	TKF 78	MY 132ML4	105
	81	1090	17.87	17600	1.35	TKA 78	MY 132ML4	106
	91	970	15.84	17400	1.45	TKAF 78	MY 132ML4	105
	107	820	13.52	17000	1.60	TK 78	MY 132ML4	104
	117	755	12.36	16300	1.35	TKF 78	MY 132ML4	105
	133	660	10.84	16000	1.50	TKA 78	MY 132ML4	106
	151	585	9.56	15700	1.60	TKAF 78	MY 132ML4	105
	170	515	8.48	15400	1.70			
	199	440	7.24	14900	1.85			
11.0	1.7	56000	835	190000	0.90	TK 188 / TRF108	MY 160M4	132
	2.0	48700	729	190000	1.05	TKH 188 / TRF108	MY 160M4	132
	2.3	41600	622	190000	1.20			
	2.8	35200	520	190000	1.40			
	3.2	30700	454	190000	1.65			
	4.0	23700	355	190000	2.1			
	1.9	49800	738	190000	1.00	TK 188 / TRF98	MY 160M4	132
	2.3	41800	621	190000	1.20	TKH 188 / TRF98	MY 160M4	132
	2.7	35400	527	190000	1.40			
	4.5	21500	318	150000	1.50	TK 168 / TRF108	MY 160M4	132
	5.2	18800	278	150000	1.70	TKH 168 / TRF108	MY 160M4	132
	5.9	16200	244	150000	1.95			
	6.8	14200	213	150000	2.3			
	7.0	13800	206	150000	2.3			
	2.6	37600	561	150000	0.85	TK 168 / TRF98	MY 160M4	132
	3.0	32400	481	150000	1.00	TKH 168 / TRF98	MY 160M4	132
	3.4	28400	423	150000	1.15			
	3.9	24800	369	150000	1.30			
	4.3	22400	333	109700	0.80	TK 158 / TRF98	MY 160M4	132
	5.0	19500	291	111400	0.90	TKF 158 / TRF98	MY 160M4	132
						TKA 158 / TRF98	MY 160M4	132
						TKAF 158 / TRF98	MY 160M4	132
	6.8	14400	213	77200	0.90	TK 128 / TRF88	MY 160M4	132
	7.2	13700	200	78600	0.90	TKF 128 / TRF88	MY 160M4	132
	8.7	11300	166	80100	1.05	TKA 128 / TRF88	MY 160M4	132
	9.8	10000	147	80700	1.20	TKAF 128 / TRF88	MY 160M4	132
	5.3	19700	134.99	150000	1.60	TK 168	MY 180L8	128
	6.6	16000	109.83	150000	2.0	TKH 168	MY 180L8	129
	5.8	18000	164.50	150000	1.80	TK 168	MY 160L6	128
	7.1	14800	134.99	150000	2.2	TKH 168	MY 160L6	129
	8.8	12000	164.50	150000	2.7	TK 168	MY 160M4	128
	11	9850	134.99	150000	3.3	TKH 168	MY 160M4	129
	5.9	17900	122.39	112300	1.00	TK 158	MY 180L8	124
	7.2	14600	100.22	113700	1.25	TKF 158	MY 180L8	125
	7.9	13400	91.65	114200	1.35	TKA 158	MY 180L8	126
	9.0	11600	79.75	114800	1.55	TKAF 158	MY 180L8	125
	6.4	16500	150.41	112900	1.10	TK 158	MY 160L6	124
	7.8	13400	122.39	114200	1.35	TKF 158	MY 160L6	125
	9.6	11000	100.22	115000	1.65	TKA 158	MY 160L6	126
	10	10000	91.65	115300	1.80	TKAF 158	MY 160L6	125
12	8730	79.75	115600	2.1				
9.6	11000	150.41	115000	1.65	TK 158	MY 160M4	124	
12	8930	122.39	115600	2.0	TKF 158	MY 160M4	125	
14	7310	100.22	115900	2.5	TKA 158	MY 160M4	126	
16	6690	91.65	116000	2.7	TKAF 158	MY 160M4	125	

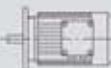
$P_{1n}$ [kW]	$n_2$ [r/min]	$M_{2n}$ [Nm]	$i$	$F_{r2}$ [N]	$f_s$			Page
<b>11.0</b>	11	9930	136.14	80700	1.30	TK 128	MY 160M4	120
	12	8930	122.48	81100	1.45	TKF 128	MY 160M4	121
	13	8040	110.18	81400	1.60	TKA 128	MY 160M4	122
	16	6560	89.89	81900	2.0	TKAF 128	MY 160M4	121
	18	5980	81.98	82100	2.2			
	20	5180	70.95*	82300	2.5			
	13	8200	112.41*	58400	1.00	TK 108	MY 160M4	116
	14	7350	100.75	58300	1.10	TKF 108	MY 160M4	117
	16	6630	90.96*	58000	1.20	TKA 108	MY 160M4	118
	17	6030	82.61	57500	1.35	TKAF 108	MY 160M4	117
	20	5350	73.30	56900	1.50	TK 108	MY 160M4	116
	22	4850	66.52*	56200	1.65	TKF 108	MY 160M4	117
	25	4170	57.17*	55100	1.90	TKA 108	MY 160M4	118
	29	3640	49.90	54000	2.2	TKAF 108	MY 160M4	117
	34	3090	42.33*	52500	2.4			
	39	2700	37.00*	51200	2.7			
	20	5150	70.54	32200	0.85	TK 98	MY 160M4	112
	23	4560	62.55	32500	0.95	TKF 98	MY 160M4	113
	25	4130	56.55	32500	1.05	TKA 98	MY 160M4	114
	30	3500	47.93*	32500	1.25	TKAF 98	MY 160M4	113
	34	3050	41.87	32200	1.40	TK 98	MY 160M4	112
	38	2790	38.30	32000	1.55	TKF 98	MY 160M4	113
	42	2500	34.23	31600	1.70	TKA 98	MY 160M4	114
	47	2250	30.82	31300	1.90	TKAF 98	MY 160M4	113
	52	2040	27.91	30800	2.1			
	58	1800	24.75	30300	2.4			
	64	1630	22.37	29800	2.6			
	33	3210	44.02	20000	0.80	TK 88	MY 160M4	108
	39	2660	36.52*	20400	0.95	TKF 88	MY 160M4	109
	46	2290	31.39	20600	1.20	TKA 88	MY 160M4	110
	52	2030	27.88	20600	1.30	TKAF 88	MY 160M4	109
	58	1820	24.92	20500	1.40			
	64	1630	22.41	20300	1.40	TK 88	MY 160M4	108
	74	1420	19.45	20100	1.60	TKF 88	MY 160M4	109
	83	1270	17.42	19800	1.75	TKA 88	MY 160M4	110
	90	1170	16.00	18800	1.55	TKAF 88	MY 160M4	109
	100	1050	14.45	19400	2.0			
	115	920	12.56	18900	2.2			
	129	810	11.17	18000	1.85			
	144	730	10.00	17700	2.1			
174	605	8.29	17100	2.3				
200	525	7.21	16700	2.5				
62	1680	23.08	14400	0.90	TK 78	MY 160M4	104	
71	1480	20.25	15900	1.00	TKF 78	MY 160M4	105	
81	1300	17.87	16600	1.10	TKA 78	MY 160M4	106	
91	1160	15.84	16500	1.20	TKAF 78	MY 160M4	105	
107	990	13.52	16300	1.35				
117	900	12.36	15500	1.10				
133	790	10.84	15300	1.25				
151	700	9.56	15100	1.35				
170	620	8.48	14800	1.45				
199	530	7.24	14500	1.55				
<b>15.0</b>	2.4	56200	622	190000	0.90	TK 188 / TRF108	MY 160L4	132
	2.8	47600	520	190000	1.05	TKH 188 / TRF108	MY 160L4	132
	3.2	41400	454	190000	1.20			
	4.1	32000	355	190000	1.55			
	5.6	23800	261	190000	2.1			

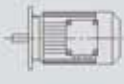

$P_{1n}$ [kW]	$n_2$ [r/min]	$M_{2n}$ [Nm]	$i$	$Fr_2$ [N]	$fs$			Page
15.0	4.6	29100	318	150000	1.10	TK 168 / TRF108	MY 160L4	132
	5.3	25300	278	150000	1.25	TKH 168 / TRF108	MY 160L4	132
	6.0	22000	244	150000	1.45			
	6.9	19200	213	150000	1.65			
	7.1	18700	206	150000	1.70			
	8.1	16100	180	150000	2.0			
	9.2	14600	160	150000	2.2			
	6.3	20600	230	110800	0.85	TK 158 / TRF108	MY 160L4	132
	6.9	19400	213	111500	0.95	TKF 158 / TRF108	MY 160L4	132
	7.8	16700	187	112800	1.05	TKA 158 / TRF108	MY 160L4	132
	9.3	14200	157	113900	1.25	TKAF 158 / TRF108	MY 160L4	132
	12	11100	122	115000	1.60			
	14	9710	107	115400	1.85			
	5.4	26600	179.86	190000	1.90	TK 188	MY 180L6	130
	5.9	24400	165.21	190000	2.1	TKH 188	MY 180L6	131
	7.2	19900	134.99	150000	1.60	TK 168	MY 180L6	128
	8.8	16200	109.83	150000	1.95	TKH 168	MY 180L6	129
	8.9	16100	164.50	150000	2.0	TK 168	MY 160L4	128
	11	13200	134.99	150000	2.4	TKH 168	MY 160L4	129
	7.9	18100	122.39	112200	1.00	TK 158	MY 180L6	124
	9.7	14800	100.22	113700	1.20	TKF 158	MY 180L6	125
	11	13500	91.65	114100	1.35	TKA 158	MY 180L6	126
	12	11800	79.75	114800	1.55	TKAF 158	MY 180L6	125
	14	10400	70.38	115200	1.75			
	9.7	14800	150.41	113700	1.20	TK 158	MY 160L4	124
	12	12000	122.39	114700	1.50	TKF 158	MY 160L4	125
	15	9830	100.22	114200	1.85	TKA 158	MY 160L4	126
	16	8990	91.65	112500	2.0	TKAF 158	MY 160L4	125
	18	7820	79.75	109600	2.3			
	11	13400	136.14	79000	0.95	TK 128	MY 160L4	120
	12	12000	122.48	79700	1.10	TKF 128	MY 160L4	121
	13	10800	110.18	80300	1.20	TKA 128	MY 160L4	122
						TKAF 128	MY 160L4	121
	16	8820	89.89	81200	1.45	TK 128	MY 160L4	120
	18	8040	81.98	81400	1.60	TKF 128	MY 160L4	121
	21	6960	70.95*	81600	1.85	TKA 128	MY 160L4	122
	23	6140	62.60	80000	2.1	TKAF 128	MY 160L4	121
	27	5300	54.07	78000	2.5			
	31	4690	47.82	76200	2.8			
	16	8920	90.96*	50900	0.90	TK 108	MY 160L4	116
	18	8110	82.61	51100	1.00	TKF 108	MY 160L4	117
	20	7190	73.30	51200	1.10	TKA 108	MY 160L4	118
	22	6530	66.52*	51000	1.25	TKAF 108	MY 160L4	117
	26	5610	57.17*	50600	1.45	TK 108	MY 160L4	116
	29	4900	49.90	50000	1.60	TKF 108	MY 160L4	117
	34	4150	42.33*	49100	1.75	TKA 108	MY 160L4	118
	39	3630	37.00*	48200	2.0	TKAF 108	MY 160L4	117
45	3210	32.69	47300	2.3				
47	3070	31.28*	47000	2.2				
50	2840	29.00	46400	2.5				
30	4700	47.93*	28100	0.90	TK 98	MY 160L4	112	
35	4110	41.87	28400	1.05	TKF 98	MY 160L4	113	
38	3760	38.30	28500	1.15	TKA 98	MY 160L4	114	
43	3360	34.23	28500	1.30	TKAF 98	MY 160L4	113	
47	3020	30.82	28400	1.40				

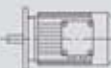

$P_{1n}$ [kW]	$n_2$ [r/min]	$M_{2n}$ [Nm]	$i$	$Fr_2$ [N]	$fs$			Page	
<b>15.0</b>	52	2740	27.91	28300	1.55	TK 98	MY 160L4	112	
	59	2430	24.75	28000	1.75	TKF 98	MY 160L4	113	
	65	2190	22.37	27700	1.95	TKA 98	MY 160L4	114	
	77	1860	18.96	27200	2.3	TKAF 98	MY 160L4	113	
	88	1620	16.56	26600	2.7				
	47	3080	31.39	17300	0.90	TK 88	MY 160L4	108	
	52	2730	27.88	17600	0.95	TKF 88	MY 160L4	109	
	59	2440	24.92	17800	1.00	TKA 88	MY 160L4	110	
	65	2200	22.41	18000	1.05	TKAF 88	MY 160L4	109	
	75	1910	19.45	18000	1.20				
	84	1710	17.42	18000	1.30				
	91	1570	16.00	16800	1.15	TK 88	MY 160L4	108	
	101	1420	14.45	17800	1.50	TKF 88	MY 160L4	109	
	116	1230	12.56	17600	1.60	TKA 88	MY 160L4	110	
	131	1100	11.17	16600	1.35	TKAF 88	MY 160L4	109	
	146	980	10.00	16400	1.55				
	176	810	8.29	16000	1.70				
	202	705	7.21	15700	1.85				
	<b>18.5</b>	2.8	58600	520	190000	0.85	TK 188 / TRF108	MY 180M4	132
		3.2	51100	454	190000	1.00	TKH 188 / TRF108	MY 180M4	132
4.1		39500	355	190000	1.25				
5.6		29400	261	190000	1.70				
6.6		24800	221	190000	2.0				
4.6		35800	318	150000	0.90	TK 168 / TRF108	MY 180M4	132	
5.3		31200	278	150000	1.00	TKH 168 / TRF108	MY 180M4	132	
6.0		27100	244	150000	1.20				
6.9		23600	213	150000	1.35				
7.1		23000	206	150000	1.40				
8.1		19900	180	150000	1.60				
9.2		18000	160	150000	1.80				
11		15200	135	150000	2.1				
12		13200	118	150000	2.4				
7.8		20700	187	110700	0.85	TK 158 / TRF108	MY 180M4	132	
9.3		17500	157	112400	1.05	TKF 158 / TRF108	MY 180M4	132	
12		13700	122	113900	1.30	TKA 158 / TRF108	MY 180M4	132	
14		12000	107	112000	1.50	TKAF 158 / TRF108	MY 180M4	132	
5.4		32800	179.86	190000	1.55	TK 188	MY 200LS6	130	
5.9		30100	165.21	190000	1.65	TKH 188	MY 200LS6	131	
6.7		26300	144.59	190000	1.90				
7.5		23600	129.69	190000	2.1				
8.2		21700	179.86	190000	2.3	TK 188	MY 180M4	130	
8.9		19900	165.21	190000	2.5	TKH 188	MY 180M4	131	
10		17400	144.59	190000	2.9				
11		15600	129.69	190000	3.2				
11		16300	134.99	150000	1.95	TK 168	MY 180M4	128	
13		13200	109.83	150000	2.4	TKH 168	MY 180M4	129	
17		10600	87.86	150000	3.0				
9.7		18300	100.22	112100	1.00	TK 158	MY 200LS6	124	
11	16700	91.65	112800	1.10	TKF 158	MY 200LS6	125		
12	14500	79.75	111500	1.25	TKA 158	MY 200LS6	126		
14	12800	70.38	109900	1.40	TKAF 158	MY 200LS6	125		
12	14800	122.39	111600	1.20	TK 158	MY 180M4	124		
15	12100	100.22	109100	1.50	TKF 158	MY 180M4	125		
16	11100	91.65	107800	1.65	TKA 158	MY 180M4	126		
18	9620	79.75	105600	1.85	TKAF 158	MY 180M4	125		
21	8490	70.38	103400	2.1					

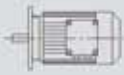
$P_{1n}$ [kW]	$n_2$ [r/min]	$M_{2n}$ [Nm]	$i$	$Fr_2$ [N]	$fs$			Page	
18.5	24	7360	61.02	100700	2.5	TK 158	MY 180M4	124	
	27	6550	54.29	98500	2.8	TKF 158	MY 180M4	125	
	31	5640	46.79	95500	3.2	TKA 158	MY 180M4	126	
	39	4580	38.02	91300	3.9	TKAF 158	MY 180M4	125	
	13	13300	110.18	79000	1.00	TK 128	MY 180M4	120	
	16	10800	89.89	79000	1.20	TKF 128	MY 180M4	121	
	18	9890	81.98	78500	1.30	TKA 128	MY 180M4	122	
							TKAF 128	MY 180M4	121
	21	8560	70.95*	77500	1.50	TK 128	MY 180M4	120	
	23	7550	62.60	76400	1.70	TKF 128	MY 180M4	121	
	27	6520	54.07	74800	2.0	TKA 128	MY 180M4	122	
	31	5770	47.82	73400	2.3	TKAF 128	MY 180M4	121	
	36	4850	40.19	71300	2.7				
	40	4370	36.25	69900	3.0				
	47	3780	31.37	68000	3.4				
	53	3340	27.68	66200	3.9				
	20	8840	73.30	46300	0.90	TK 108	MY 180M4	116	
	22	8020	66.52*	46600	1.00	TKF 108	MY 180M4	117	
	26	6890	57.17*	46800	1.15	TKA 108	MY 180M4	118	
	29	6020	49.90	46700	1.30	TKAF 108	MY 180M4	117	
	35	5100	42.33*	46300	1.45	TK 108	MY 180M4	116	
	40	4460	37.00*	45700	1.60	TKF 108	MY 180M4	117	
	45	3940	32.69	45100	1.85	TKA 108	MY 180M4	118	
	47	3770	31.28*	44900	1.80	TKAF 108	MY 180M4	117	
	51	3500	29.00	44400	2.1				
	56	3170	26.32	43800	2.3				
	65	2730	22.62	42700	2.6				
	74	2380	19.74	41700	3.0				
	88	2020	16.75	40400	3.5				
	35	5050	41.87	25100	0.85	TK 98	MY 180M4	112	
	48	3720	30.82	26000	1.15	TKF 98	MY 180M4	113	
	53	3360	27.91	26000	1.30	TKA 98	MY 180M4	114	
	59	2980	24.75	26000	1.45	TKAF 98	MY 180M4	113	
	65	2700	22.37	25900	1.60	TK 98	MY 180M4	112	
	77	2290	18.96	25700	1.90	TKF 98	MY 180M4	113	
	88	2000	16.56	25300	2.2	TKA 98	MY 180M4	114	
	106	1670	13.85	24800	2.6	TKAF 98	MY 180M4	113	
	122	1450	11.99	24300	2.7				
	59	3000	24.92	15600	0.85	TK 88	MY 180M4	108	
	65	2700	22.41	15900	0.85	TKF 88	MY 180M4	109	
	75	2340	19.45	16200	1.00	TKA 88	MY 180M4	110	
	84	2100	17.42	16400	1.05	TKAF 88	MY 180M4	109	
	101	1740	14.45	16500	1.20				
	117	1510	12.56	16400	1.30				
	131	1350	11.17	15400	1.10				
	147	1210	10.00	15300	1.25				
	177	1000	8.29	15100	1.40				
203	870	7.21	14900	1.50					
22	3.2	60800	454	190000	0.80	TK 188 / TRF108	MY 180L4	132	
	4.1	47100	355	190000	1.05	TKH 188 / TRF108	MY 180L4	132	
	5.6	35000	261	190000	1.45				
	6.6	29600	221	190000	1.70				
	7.6	25800	193	190000	1.95				
	9.0	21800	163	190000	2.3				
	5.3	37200	278	150000	0.85	TK 168 / TRF108	MY 180L4	132	
	6.0	32300	244	150000	1.00	TKH 168 / TRF108	MY 180L4	132	

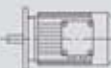

P <sub>1n</sub> [kW]	n <sub>2</sub> [r/min]	M <sub>2n</sub> [Nm]	i	Fr <sub>2</sub> [N]	fs			Page	
22	6.9	28200	213	150000	1.15	TK 168 / TRF108	MY 180L4	132	
	7.1	27500	206	150000	1.15	TKH 168 / TRF108	MY 180L4	132	
	8.1	23800	180	150000	1.35				
	9.2	21400	160	150000	1.50				
	11	18100	135	150000	1.75				
	12	15800	118	150000	2.0				
	9.3	20900	157	109400	0.85	TK 158 / TRF108	MY 180L4	132	
	12	16400	122	108100	1.10	TKF 158 / TRF108	MY 180L4	132	
	14	14300	107	107000	1.25	TKA 158 / TRF108	MY 180L4	132	
							TKAF 158 / TRF108	MY 180L4	132
	5.4	39000	179.86	190000	1.30	TK 188	MY 200L6	130	
	5.9	35800	165.21	190000	1.40	TKH 188	MY 200L6	131	
	6.7	31300	144.59	190000	1.60				
	7.5	28100	129.69	190000	1.80				
	8.6	24400	112.60	190000	2.1				
	8.2	25800	179.86	190000	1.95	TK 188	MY 180L4	130	
	8.9	23700	165.21	190000	2.1	TKH 188	MY 180L4	131	
	10	20700	144.59	190000	2.4				
	11	18600	129.69	190000	2.7				
	11	19400	134.99	150000	1.65	TK 168	MY 180L4	128	
	13	15700	109.83	150000	2.0	TKH 168	MY 180L4	129	
	17	12600	87.86	150000	2.5				
	19	11200	78.14	150000	2.9				
	9.7	21700	100.22	105900	0.85	TK 158	MY 200L6	124	
	11	19900	91.65	105900	0.90	TKF 158	MY 200L6	125	
	12	17300	79.75	105500	1.05	TKA 158	MY 200L6	126	
	14	15200	70.38	104600	1.20	TKAF 158	MY 200L6	125	
	16	13200	61.02	103300	1.35				
	12	17600	122.39	105500	1.05	TK 158	MY 180L4	124	
	15	14400	100.22	104100	1.25	TKF 158	MY 180L4	125	
	16	13100	91.65	103200	1.35	TKA 158	MY 180L4	126	
	18	11400	79.75	101600	1.55	TKAF 158	MY 180L4	125	
	21	10100	70.38	99800	1.80				
	24	8750	61.02	97700	2.1				
	27	7790	54.29	95800	2.3				
	31	6710	46.79	93200	2.7				
	39	5450	38.02	89400	3.3				
	16	12900	89.89	73900	1.00	TK 128	MY 180L4	120	
	18	11800	81.98	73800	1.10	TKF 128	MY 180L4	121	
	21	10200	70.95*	73400	1.30	TKA 128	MY 180L4	122	
	23	8980	62.60	72800	1.45	TKAF 128	MY 180L4	121	
	27	7750	54.07	71700	1.70	TK 128	MY 180L4	120	
	31	6860	47.82	70700	1.90	TKF 128	MY 180L4	121	
	36	5760	40.19	69000	2.3	TKA 128	MY 180L4	122	
	40	5200	36.25	67800	2.5	TKAF 128	MY 180L4	121	
	47	4500	31.37	66200	2.9				
	53	3970	27.68	64600	3.3				
	61	3430	23.91	62800	3.8				
	69	3030	21.15	61200	4.3				
	26	8200	57.17*	43000	1.00	TK 108	MY 180L4	116	
29	7160	49.90	43300	1.10	TKF 108	MY 180L4	117		
35	6070	42.33*	43400	1.20	TKA 108	MY 180L4	118		
					TKAF 108	MY 180L4	117		
40	5310	37.00*	43200	1.35	TK 108	MY 180L4	116		
45	4690	32.69	42900	1.55	TKF 108	MY 180L4	117		
47	4490	31.28*	42800	1.50	TKA 108	MY 180L4	118		
51	4160	29.00	42500	1.75	TKAF 108	MY 180L4	117		



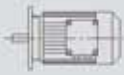

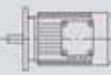
$P_{1n}$ [kW]	$n_2$ [r/min]	$M_{2n}$ [Nm]	$i$	$Fr_2$ [N]	$fs$			Page	
<b>22</b>	56	3770	26.32	42000	1.90	TK 108	MY 180L4	116	
	65	3240	22.62	41200	2.2	TKF 108	MY 180L4	117	
	74	2830	19.74	40400	2.5	TKA 108	MY 180L4	118	
	88	2400	16.75	39300	2.9	TKAF 108	MY 180L4	117	
	100	2100	14.64	38400	3.3				
	109	1930	13.43	36800	2.2				
	125	1680	11.73	35900	2.6				
	147	1430	9.94	34800	2.9				
	48	4420	30.82	23500	0.95	TK 98	MY 180L4	112	
	53	4000	27.91	23800	1.05	TKF 98	MY 180L4	113	
	59	3550	24.75	24100	1.20	TKA 98	MY 180L4	114	
	65	3210	22.37	24200	1.35	TKAF 98	MY 180L4	113	
	77	2720	18.96	24100	1.60	TK 98	MY 180L4	112	
	88	2370	16.56	24000	1.80	TKF 98	MY 180L4	113	
	106	1990	13.85	23700	2.2	TKA 98	MY 180L4	114	
	122	1720	11.99	23300	2.3	TKAF 98	MY 180L4	113	
	141	1490	10.41	21800	1.9				
	168	1250	8.71	21300	2.1				
	75	2790	19.45	14400	0.80	TK 88	MY 180L4	108	
	84	2500	17.42	14800	0.90	TKF 88	MY 180L4	109	
	101	2070	14.45	15100	1.00	TKA 88	MY 180L4	110	
	117	1800	12.56	15300	1.10	TKAF 88	MY 180L4	109	
	131	1600	11.17	14200	0.95				
	147	1430	10	14200	1.05				
	177	1190	8.29	14300	1.20				
	203	1030	7.21	14200	1.25				
	<b>30</b>	5.6	47700	261	190000	1.05	TK 188 / TRF108	MY 200L4	132
		6.6	40400	221	190000	1.25	TKH 188 / TRF108	MY 200L4	132
7.6		35200	193	190000	1.40				
9.0		29700	163	190000	1.70				
6.9		38400	213	150000	0.85	TK 168 / TRF108	MY 200L4	132	
7.1		37500	206	150000	0.85	TKH 168 / TRF108	MY 200L4	132	
8.2		32400	180	150000	1.00				
9.2		29100	160	150000	1.10				
11		24700	135	150000	1.30				
12		21500	118	150000	1.50				
8.2		35100	179.86	190000	1.45	TK 188	MY 200L4	130	
8.9		32200	165.21	190000	1.55	TKH 188	MY 200L4	131	
10		28200	144.59	190000	1.75				
11		25300	129.69	190000	2.0				
13		21900	112.60	190000	2.3				
14		19900	102.16	190000	2.5				
17		17200	88.00	190000	2.9				
13		21400	109.83	150000	1.50	TK 168	MY 200L4	128	
17		17100	87.86	150000	1.85	TKH 168	MY 200L4	129	
19		15200	78.14	150000	2.1				
22		13300	68.07	150000	2.4				
24		11800	60.74	150000	2.7				
15		19500	100.22	92700	0.90	TK 158	MY 200L4	124	
16		17900	91.65	92800	1.00	TKF 158	MY 200L4	125	
18		15500	79.75	92400	1.15	TKA 158	MY 200L4	126	
21		13700	70.38	91800	1.30	TKAF 158	MY 200L4	125	
24		11900	61.02	90700	1.50				
27		10600	54.29	89500	1.70				
31	9120	46.79	87800	1.95					
39	7410	38.02	85100	2.4					
47	6100	31.30	82200	3.0					

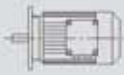
$P_{1n}$ [kW]	$n_2$ [r/min]	$M_{2n}$ [Nm]	$i$	$F_{r2}$ [N]	$f_s$			Page
<b>30</b>	21	13800	70.95*	64200	0.95	TK 128	MY 200L4	120
	23	12200	62.60	64600	1.05	TKF 128	MY 200L4	121
	27	10500	54.07	64700	1.25	TKA 128	MY 200L4	122
	31	9320	47.82	64400	1.40	TKAF 128	MY 200L4	121
	37	7830	40.19	63700	1.65			
	41	7060	36.25	63100	1.85			
	47	6110	31.37	62000	2.1			
	53	5390	27.68	61000	2.4			
	62	4660	23.91	59600	2.8			
	35	8250	42.33*	36100	0.90	TK 108	MY 200L4	116
	40	7210	37.00*	37600	1.00	TKF 108	MY 200L4	117
	47	6100	31.28*	38000	1.10	TKA 108	MY 200L4	118
						TKAF 108	MY 200L4	117
	51	5650	29.00	38000	1.25	TK 108	MY 200L4	116
	56	5130	26.32	38000	1.40	TKF 108	MY 200L4	117
	65	4410	22.62	37700	1.65	TKA 108	MY 200L4	118
	74	3850	19.74	37400	1.85	TKAF 108	MY 200L4	117
	88	3260	16.75	36700	2.2			
	100	2850	14.64	36100	2.4			
	109	2620	13.43	34400	1.65			
	125	2280	11.73	33800	1.90			
	148	1940	9.94	33000	2.2			
	169	1690	8.69	32200	2.4			
	59	4820	24.75	19600	0.90	TK 98	MY 200L4	112
	66	4360	22.37	20100	1.00	TKF 98	MY 200L4	113
	78	3690	18.96	20700	1.15	TKA 98	MY 200L4	114
	89	3230	16.56	21000	1.35	TKAF 98	MY 200L4	113
	106	2700	13.85	21200	1.60			
	123	2340	11.99	21100	1.65			
	141	2030	10.41	19500	1.40			
	169	1700	8.71	19400	1.55			
	<b>37</b>	5.6	58800	261	190000	0.85	TK 188 / TRF108	MY 225S4
6.6		49900	221	190000	1.00	TKH 188 / TRF108	MY 225S4	132
7.6		43500	193	190000	1.15			
9.0		36700	163	190000	1.35			
8.2		40100	180	150000	0.80	TK 168 / TRF108	MY 225S4	132
9.2		36000	160	150000	0.90	TKH 168 / TRF108	MY 225S4	132
11		30500	135	150000	1.05			
12		26600	118	150000	1.20			
8.2		43200	179.86	190000	1.15	TK 188	MY 225S4	130
8.9		39700	165.21	190000	1.25	TKH 188	MY 225S4	131
10		34800	144.59	190000	1.45			
11		31200	129.69	190000	1.60			
13		27100	112.60	190000	1.85			
14		24600	102.16	190000	2.0			
17		21200	88.00	190000	2.4			
13		26400	109.83	150000	1.20	TK 168	MY 225S4	128
17		21100	87.86	150000	1.50	TKH 168	MY 225S4	129
19		18800	78.14	150000	1.70			
22		16400	68.07	150000	1.95			
24		14600	60.74	150000	2.2			
28		12400	51.77	150000	2.6			
16		22000	91.65	83600	0.80	TK 158	MY 225S4	124
18	19200	79.75	84500	0.95	TKF 158	MY 225S4	125	
					TKA 158	MY 225S4	126	
					TKAF 158	MY 225S4	125	

$P_{1n}$ [kW]	$n_2$ [r/min]	$M_{2n}$ [Nm]	$i$	$Fr_2$ [N]	$fs$			Page
37	21	16900	70.38	84800	1.05	TK 158	MY 225S4	124
	24	14700	61.02	84600	1.25	TKF 158	MY 225S4	125
	27	13000	54.29	84100	1.40	TKA 158	MY 225S4	126
	31	11200	46.79	83200	1.60	TKAF 158	MY 225S4	125
	39	9140	38.02	81300	1.95			
	47	7520	31.30	79100	2.4			
	23	15000	62.60	57500	0.85	TK 128	MY 225S4	120
	27	13000	54.07	58500	1.00	TKF 128	MY 225S4	121
	31	11500	47.82	59000	1.15	TKA 128	MY 225S4	122
	37	9660	40.19	59100	1.35	TKAF 128	MY 225S4	121
	41	8710	36.25	59000	1.50	TK 128	MY 225S4	120
	47	7540	31.37	58500	1.70	TKF 128	MY 225S4	121
	53	6650	27.68	57800	1.95	TKA 128	MY 225S4	122
	62	5740	23.91	56900	2.3	TKAF 128	MY 225S4	121
	70	5080	21.15	56000	2.6			
	83	4270	17.77	54500	3.0			
	102	3450	14.35	52500	3.5			
	115	3070	12.79	50200	2.8			
	137	2580	10.74	48600	3.1			
	169	2090	8.68	46600	3.5			
	40	8890	37.00*	29000	0.80	TK 108	MY 225S4	116
	47	7520	31.28*	33000	0.90	TKF 108	MY 225S4	117
	51	6970	29.00	34200	1.05	TKA 108	MY 225S4	118
	56	6320	26.32	34500	1.15	TKAF 108	MY 225S4	117
	65	5440	22.62	34700	1.30			
	74	4740	19.74	34700	1.50			
	88	4020	16.75	34500	1.75			
	100	3520	14.64	34200	1.95			
	109	3230	13.43	32300	1.35			
	125	2820	11.73	32000	1.55			
	148	2390	9.94	31400	1.75			
	169	2090	8.69	30900	1.95			
	45	6.6	60700	221.00	190000	0.80	TK 188 / TRF108	MY 225M4
7.6		53000	193.00	190000	0.95	TKH 188 / TRF108	MY 225M4	132
9.0		44800	163.00	190000	1.10			
11		37100	135.00	150000	0.85	TK 168 / TRF108	MY 225M4	132
12		32400	118.00	150000	1.00	TKH 168 / TRF108	MY 225M4	132
8.2		52600	179.86	185500	0.95	TK 188	MY 225M4	130
8.9		48300	165.21	190000	1.05	TKH 188	MY 225M4	131
10		42300	144.59	190000	1.20			
11		37900	129.69	190000	1.30			
13		32900	112.60	190000	1.50			
14		29900	102.16	190000	1.65			
17		25700	88.00	190000	1.95			
20		21600	73.96	187700	2.3			
13		32100	109.83	150000	1.00	TK 168	MY 225M4	128
17		25700	87.86	150000	1.25	TKH 168	MY 225M4	129
19		22800	78.14	150000	1.40			
22		19900	68.07	150000	1.60			
24		17800	60.74	149000	1.80			
28		15100	51.77	145300	2.1			
34		12500	42.89	140600	2.6			
21		20600	70.38	76800	0.85	TK 158	MY 225M4	124
24	17800	61.02	77700	1.00	TKF 158	MY 225M4	125	
27	15900	54.29	77900	1.15	TKA 158	MY 225M4	126	
31	13700	46.79	77800	1.30	TKAF 158	MY 225M4	125	

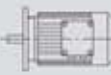

$P_{1n}$ [kW]	$n_2$ [r/min]	$M_{2n}$ [Nm]	$i$	$F_{R2}$ [N]	$f_s$			Page	
<b>45</b>	39	11100	38.02	76900	1.60	TK 158	MY 225M4	124	
	47	9150	31.30	75500	1.95	TKF 158	MY 225M4	125	
	53	8080	27.62	74300	2.2	TKA 158	MY 225M4	126	
	61	7000	23.95	72800	2.6	TKAF 158	MY 225M4	125	
	69	6230	21.31	71500	2.9				
	80	5370	18.37	69700	3.4				
	31	14000	47.82	52800	0.95	TK 128	MY 225M4	120	
	37	11700	40.19	53900	1.10	TKF 128	MY 225M4	121	
	41	10600	36.25	54200	1.25	TKA 128	MY 225M4	122	
						TKAF 128	MY 225M4	121	
	47	9170	31.37	54400	1.40	TK 128	MY 225M4	120	
	53	8090	27.68	54200	1.60	TKF 128	MY 225M4	121	
	62	6990	23.91	53800	1.85	TKA 128	MY 225M4	122	
	70	6180	21.15	53200	2.1	TKAF 128	MY 225M4	121	
	83	5190	17.77	52200	2.5				
	102	4190	14.35	50700	2.9				
	115	3740	12.79	48300	2.3				
	137	3140	10.74	47000	2.6				
	169	2540	8.68	45300	2.9				
	51	8480	29.00	25600	0.85	TK 108	MY 225M4	116	
	56	7690	26.32	28300	0.95	TKF 108	MY 225M4	117	
	65	6610	22.62	31000	1.10	TKA 108	MY 225M4	118	
	74	5770	19.74	31700	1.25	TKAF 108	MY 225M4	117	
	88	4890	16.75	31900	1.45	TK 108	MY 225M4	116	
	100	4280	14.64	31900	1.60	TKF 108	MY 225M4	117	
	109	3930	13.43	29900	1.10	TKA 108	MY 225M4	118	
	125	3430	11.73	29900	1.25	TKAF 108	MY 225M4	117	
	148	2910	9.94	29600	1.45				
	169	2540	8.69	29300	1.60				
	<b>55</b>	10	51500	144.59	187400	0.95	TK 188	MY 250M4	130
		11	46200	129.69	190000	1.10	TKH 188	MY 250M4	131
		13	40100	112.60	188500	1.25			
14		36400	102.16	187100	1.35				
17		31300	88.00	184200	1.60				
20		26300	73.96	180200	1.90				
23		22800	64.04	176300	2.2				
17		31300	87.86	145300	1.00	TK 168	MY 250M4	128	
19		27800	78.14	144600	1.15	TKH 168	MY 250M4	129	
22		24200	68.07	143300	1.30				
24		21600	60.74	141700	1.50				
28		18400	51.77	139100	1.75				
34		15300	42.89	135400	2.1				
40		13000	36.61	131900	2.5				
24		21700	61.02	69000	0.85	TK 158	MY 250M4	124	
27		19300	54.29	70200	0.95	TKF 158	MY 250M4	125	
32		16700	46.79	71200	1.10	TKA 158	MY 250M4	126	
39		13500	38.02	71500	1.35	TKAF 158	MY 250M4	125	
47		11100	31.30	71000	1.60				
53		9840	27.62	70400	1.85				
62		8530	23.95	69400	2.1				
69		7590	21.31	68400	2.4				
80		6540	18.37	67000	2.8				
99	5310	14.92	64800	3.4					
117	4510	12.65	62900	3.8					

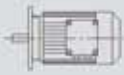

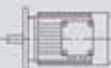
$P_{1n}$ [kW]	$n_2$ [r/min]	$M_{2n}$ [Nm]	$i$	$Fr_2$ [N]	$fs$			Page	
55	37	14300	40.19	47400	0.90	TK 128	MY 250M4	120	
	47	11200	31.37	49300	1.15	TKF 128	MY 250M4	121	
	53	9850	27.68	49700	1.30	TKA 128	MY 250M4	122	
						TKAF 128	MY 250M4	121	
	62	8510	23.91	49900	1.55	TK 128	MY 250M4	120	
	70	7530	21.15	49800	1.75	TKF 128	MY 250M4	121	
	83	6330	17.77	49300	2.1	TKA 128	MY 250M4	122	
	103	5110	14.35	48300	2.4	TKAF 128	MY 250M4	121	
	115	4550	12.79	45900	1.85				
	137	3830	10.74	45000	2.1				
	170	3090	8.68	43600	2.3				
	75	11	62800	129.69	164100	0.80	TK 188	MY 280S4	130
		13	54500	112.60	166100	0.90	TKH 188	MY 280S4	131
		14	49400	102.16	166600	1.00			
17		42600	88.00	166600	1.15				
20		35800	73.96	165300	1.40				
23		31000	64.04	163400	1.60				
28		25800	53.36	160100	1.95				
33		22000	45.50*	156700	2.3				
19		37800	78.14	126100	0.85	TK 168	MY 280S4	128	
22		32900	68.07	127100	0.95	TKH 168	MY 280S4	129	
24		29400	60.74	127300	1.10				
29		25100	51.77	126800	1.30				
35		20800	42.89	125200	1.55				
40		17700	36.61	123200	1.80				
46		15600	32.25	121300	2.1				
51		13900	28.77	119300	2.3				
60		11900	24.52	116300	2.7				
39		18400	38.02	60800	1.00	TK 158	MY 280S4	124	
47		15100	31.30	62200	1.20	TKF 158	MY 280S4	125	
54		13400	27.62	62600	1.35	TKA 158	MY 280S4	126	
62		11600	23.95	62600	1.55	TKAF 158	MY 280S4	125	
69		10300	21.31	62400	1.75				
81		8890	18.37	61800	2.0				
99		7220	14.92	60500	2.5				
117		6120	12.65	59300	2.8				
47		15200	31.37	39200	0.85	TK 128	MY 280S4	120	
53		13400	27.68	40800	0.95	TKF 128	MY 280S4	121	
62		11600	23.91	42200	1.10	TKA 128	MY 280S4	122	
70		10200	21.15	42900	1.25	TKAF 128	MY 280S4	121	
83		8600	17.77	43500	1.50				
103		6940	14.35	43700	1.75				
116		6190	12.79	41100	1.40				
138		5200	10.74	41000	1.55				
171		4200	8.68	40400	1.70				
90	14	59300	102.16	151300	0.85	TK 188	MY 280M4	130	
	17	51100	88.00	153400	1.00	TKH 188	MY 280M4	131	
	20	42900	73.96	154200	1.15				
	23	37200	64.04	153800	1.35				
	28	31000	53.36	152200	1.60				
	33	26400	45.50*	149900	1.90				
	35	24700	42.51	148700	2.0				
	38	22400	38.57	146900	2.2				
	22	39500	68.07	115100	0.80	TK 168	MY 280M4	128	
	24	35300	60.74	116600	0.90	TKH 168	MY 280M4	129	
	29	30100	51.77	117600	1.05				

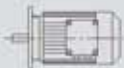

$P_{1n}$ [kW]	$n_2$ [r/min]	$M_{2n}$ [Nm]	$i$	$Fr_2$ [N]	$fs$			Page
<b>90</b>	35	24900	42.89	117600	1.30	TK 168	MY 280M4	128
	40	21300	36.61	116700	1.50	TKH 168	MY 280M4	129
	46	18700	32.25	115500	1.70			
	51	16700	28.77	114200	1.90			
	60	14200	24.52	111900	2.3			
	73	11800	20.32	108800	2.7			
	85	10100	17.34	106000	3.2			
	39	22100	38.02	52700	0.80	TK 158	MY 280M4	124
	62	13900	23.95	57500	1.30	TKF 158	MY 280M4	125
	69	12400	21.31	57900	1.45	TKA 158	MY 280M4	126
	81	10700	18.37	57900	1.70	TKAF 158	MY 280M4	125
	99	8670	14.92	57400	2.1			
	117	7350	12.65	56600	2.3			
	62	13900	23.91	36400	0.95	TK 128	MY 280M4	120
	70	12300	21.15	37800	1.05	TKF 128	MY 280M4	121
	83	10300	17.77	39200	1.25	TKA 128	MY 280M4	122
	103	8330	14.35	40200	1.45	TKAF 128	MY 280M4	121
116	7420	12.79	37600	1.15				
138	6240	10.74	39000	1.30				
171	5040	8.68	39000	1.45				
<b>110</b>	17	62300	88.00	136000	0.80	TK 188	MY 315S4	130
	20	52300	73.96	139500	0.95	TKH 188	MY 315S4	131
	23	45300	64.04	141000	1.10			
	28	37700	53.36	141500	1.30			
	33	32200	45.50*	140800	1.55			
	35	30100	42.51	140200	1.65			
	39	27300	38.57	139100	1.85			
	45	23500	33.23	137000	2.1			
	53	19800	27.92	134000	2.5			
	29	36600	51.77	105500	0.85	TK 168	MY 315S4	128
	35	30300	42.89	107500	1.05	TKH 168	MY 315S4	129
	41	25900	36.61	108100	1.25			
	46	22800	32.25	107900	1.40			
	52	20400	28.77	107400	1.55			
	61	17300	24.52	106100	1.85			
	73	14400	20.32	104000	2.2			
	86	12300	17.34	101800	2.6			
62	16900	23.95	50800	1.05	TK 158	MY 315S4	124	
70	15100	21.31	51900	1.20	TKF 158	MY 315S4	125	
81	13000	18.37	52700	1.40	TKA 158	MY 315S4	126	
100	10600	14.92	53100	1.70	TKAF 158	MY 315S4	125	
117	8950	12.65	53000	1.90				
<b>132</b>	20	62800	73.96	123300	0.80	TK 188	MY 315M4	130
	23	54400	64.04	127000	0.90	TKH 188	MY 315M4	131
	28	45300	53.36	129800	1.10			
	33	38600	45.50*	130800	1.30			
	35	36100	42.51	130900	1.40			
	39	32700	38.57	130700	1.55			
	45	28200	33.23	129800	1.75			
	53	23700	27.92	127900	2.1			
	61	20500	24.18	125900	2.3			
	74	17100	20.15	122800	2.6			
	86	14600	17.18	119700	2.8			
35	36400	42.89	96400	0.90	TK 168	MY 315M4	128	
41	31100	36.61	98600	1.05	TKH 168	MY 315M4	129	
46	27400	32.25	99600	1.15				





$P_{1n}$ [kW]	$n_2$ [r/min]	$M_{2n}$ [Nm]	$i$	$Fr_2$ [N]	$fs$			Page	
<b>132</b>	52	24400	28.77	99900	1.30	TK 168	MY 315M4	128	
	61	20800	24.52	99800	1.55	TKH 168	MY 315M4	129	
	73	17200	20.32	98700	1.85				
	86	14700	17.34	97300	2.2				
	62	20300	23.95	43400	0.90	TK 158	MY 315M4	124	
	70	18100	21.31	45300	1.00	TKF 158	MY 315M4	125	
	81	15600	18.37	47000	1.15	TKA 158	MY 315M4	126	
	100	12700	14.92	48500	1.40	TKAF 158	MY 315M4	125	
	117	10700	12.65	49100	1.60				
	<b>160</b>	28	54900	53.36	114900	0.90	TK 188	MY 315M4A	130
		33	46800	45.50*	118100	1.05	TKH 188	MY 315M4A	131
45		34200	33.23	120500	1.45				
53		28700	27.92	120100	1.75				
61		24900	24.18	119100	1.90				
74		20700	20.15	117200	2.1				
86		17700	17.18	114900	2.3				
41		37700	36.61	86500	0.85	TK 168	MY 315M4A	128	
61		25200	24.52	91700	1.25	TKH 168	MY 315M4A	129	
73		20900	20.32	92000	1.55				
86		17800	17.34	91600	1.80				
81		18900	18.37	39800	0.95	TK 158	MY 315M4A	124	
100		15400	14.92	42600	1.15	TKF 158	MY 315M4A	125	
117		13000	12.65	44100	1.30	TKA 158	MY 315M4A	126	
						TKAF 158	MY 315M4A	125	
<b>200</b>		33	58500	45.50*	100000	0.85	TK 188	MY 315M4B	130
		45	42700	33.23	107300	1.15	TKH 188	MY 315M4B	131
	53	35900	27.92	109000	1.40				
	61	31100	24.18	109500	1.55				
	74	25900	20.15	109100	1.70				
	86	22100	17.18	108100	1.85				
	61	31500	24.52	80100	1.00	TK 168	MY 315M4B	128	
	73	26100	20.32	82400	1.20	TKH 168	MY 315M4B	129	
	86	22300	17.34	83400	1.45				
	100	19200	14.92	34200	0.95	TK 158	MY 315M4B	124	
	117	16300	12.65	36900	1.05	TKF 158	MY 315M4B	125	
						TKA 158	MY 315M4B	126	
						TKAF 158	MY 315M4B	125	



## 6.3 TK../TRF..MY.. Performance parameter



$M_2 \text{ max}$ [Nm]	$n_2$ [r/min]	$i$	$F_{r2}$ [N]				Page	
200	0.20	6832	5640	TK	38 / TRF18	MY 63S4	132	
	0.23	5922	5640	TKF	38 / TRF18	MY 63S4	132	
	0.25	5491	5640	TKA	38 / TRF18	MY 63S4	132	
	0.29	4759	5640	TKAF	38 / TRF18	MY 63S4	132	
	0.33	4160	5640					
	0.38	3645	5640					
	0.43	3205	5640					
	0.49	2801	5640					
	0.56	2454	5640					
	0.64	2166	5640					
	0.73	1891	5640					
	0.83	1660	5640					
	0.94	1466	5640					
	1.1	1288	5640					
	1.2	1136	5640					
	1.4	996	5640		TK	38 / TRF18	MY 63S4	132
	1.6	876	5640		TKF	38 / TRF18	MY 63S4	132
	1.8	761	5640		TKA	38 / TRF18	MY 63S4	132
	2.1	671	5640		TKAF	38 / TRF18	MY 63S4	132
	2.4	585	5640					
	2.7	512	5640					
	3.1	451	5640					
	3.5	396	5640					
	4.0	346	5640					
	4.3	304	5640		TK	38 / TRF18	MY 63M4	132
	4.9	267	5640		TKF	38 / TRF18	MY 63M4	132
	5.7	234	5640		TKA	38 / TRF18	MY 63M4	132
	6.4	205	5640		TKAF	38 / TRF18	MY 63M4	132
	7.2	181	5640		TK	38 / TRF18	MY 63L4	132
	8.1	160	5640		TKF	38 / TRF18	MY 63L4	132
	9.5	136	5640		TKA	38 / TRF18	MY 63L4	132
	10	127	5640		TKAF	38 / TRF18	MY 63L4	132
	12	110	5640		TK	38 / TRF18	MY 71D4	132
	14	96	5640		TKF	38 / TRF18	MY 71D4	132
					TKA	38 / TRF18	MY 71D4	132
					TKAF	38 / TRF18	MY 71D4	132
	400	0.14	10138	5920	TK	48 / TRF38	MY 63S4	132
		0.16	8534	5920	TKF	48 / TRF38	MY 63S4	132
0.18		7662	5920	TKA	48 / TRF38	MY 63S4	132	
0.20		6826	5920	TKAF	48 / TRF38	MY 63S4	132	
0.23		5983	5920					
0.27		5159	5920					
0.30		4601	5920					
0.35		3940	5920					
0.40		3477	5920					
0.45		3043	5920					
0.51		2733	5920					
0.59		2354	5920					
0.67		2063	5920					
0.76		1819	5920					
0.87		1586	5920					
0.99		1388	5920					

$M_{2 \max}$ [Nm]	$n_2$ [r/min]	$i$	$F_{r2}$ [N]				Page
<b>400</b>	1.1	1222	5920	TK	48 / TRF38	MY 63S4	132
	1.3	1097	5920	TKF	48 / TRF38	MY 63S4	132
	1.5	945	5920	TKA	48 / TRF38	MY 63S4	132
	1.7	831	5920	TKAF	48 / TRF38	MY 63S4	132
	1.9	718	5920				
	2.2	639	5920				
	2.4	552	5920	TK	48 / TRF38	MY 63M4	132
	2.7	495	5920	TKF	48 / TRF38	MY 63M4	132
	3.1	426	5920	TKA	48 / TRF38	MY 63M4	132
				TKAF	48 / TRF38	MY 63M4	132
	3.5	375	5920	TK	48 / TRF38	MY 63L4	132
	4.0	327	5920	TKF	48 / TRF38	MY 63L4	132
	4.5	289	5920	TKA	48 / TRF38	MY 63L4	132
				TKAF	48 / TRF38	MY 63L4	132
	5.4	256	5920	TK	48 / TRF38	MY 71D4	132
	6.2	225	5920	TKF	48 / TRF38	MY 71D4	132
	7.0	198	5920	TKA	48 / TRF38	MY 71D4	132
				TKAF	48 / TRF38	MY 71D4	132
	8.0	171	5920	TK	48 / TRF38	MY 80K4	132
	8.9	153	5920	TKF	48 / TRF38	MY 80K4	132
10	131	5920	TKA	48 / TRF38	MY 80K4	132	
			TKAF	48 / TRF38	MY 80K4	132	
<b>600</b>	0.11	12169	7630	TK	58 / TRF38	MY 63S4	132
	0.12	11162	7630	TKF	58 / TRF38	MY 63S4	132
	0.15	9503	7630	TKA	58 / TRF38	MY 63S4	132
	0.16	8547	7630	TKAF	58 / TRF38	MY 63S4	132
	0.19	7277	7630				
	0.21	6478	7630				
	0.24	5662	7630				
	0.27	5033	7630				
	0.32	4340	7630				
	0.36	3854	7630				
	0.41	3390	7630				
	0.47	2924	7630				
	0.53	2593	7630				
	0.61	2249	7630				
	0.70	1986	7630				
	0.79	1743	7630	TK	58 / TRF38	MY 63S4	132
	0.90	1539	7630	TKF	58 / TRF38	MY 63S4	132
	1.0	1354	7630	TKA	58 / TRF38	MY 63S4	132
	1.2	1174	7630	TKAF	58 / TRF38	MY 63S4	132
	1.3	1036	7630				
	1.5	906	7630	TK	58 / TRF38	MY 63M4	132
	1.6	806	7630	TKF	58 / TRF38	MY 63M4	132
	1.9	699	7630	TKA	58 / TRF38	MY 63M4	132
	2.1	615	7630	TKAF	58 / TRF38	MY 63M4	132
	2.4	544	7630	TK	58 / TRF38	MY 63L4	132
	2.8	473	7630	TKF	58 / TRF38	MY 63L4	132
	3.1	421	7630	TKA	58 / TRF38	MY 63L4	132
				TKAF	58 / TRF38	MY 63L4	132
	3.8	362	7630	TK	58 / TRF38	MY 71D4	132
	4.3	319	7630	TKF	58 / TRF38	MY 71D4	132
4.9	280	7630	TKA	58 / TRF38	MY 71D4	132	
			TKAF	58 / TRF38	MY 71D4	132	









$M_{2\ max}$ [Nm]	$n_2$ [r/min]	$i$	$F_{r_2}$ [N]				Page	
<b>600</b>	5.5	246	7630	TK	58 / TRF38	MY 80K4	132	
	6.3	215	7630	TKF	58 / TRF38	MY 80K4	132	
	7.1	192	7630	TKA	58 / TRF38	MY 80K4	132	
				TKAF	58 / TRF38	MY 80K4	132	
	8.3	166	7630	TK	58 / TRF38	MY 80N4	132	
	9.6	145	7630	TKF	58 / TRF38	MY 80N4	132	
	11	129	7630	TKA	58 / TRF38	MY 80N4	132	
				TKAF	58 / TRF38	MY 80N4	132	
	13	111	7630	TK	58 / TRF38	MY 90S4	132	
	14	97	7630	TKF	58 / TRF38	MY 90S4	132	
				TKA	58 / TRF38	MY 90S4	132	
				TKAF	58 / TRF38	MY 90S4	132	
	<b>820</b>	0.11	12139	10300	TK	68 / TRF38	MY 63S4	132
		0.12	11134	10300	TKF	68 / TRF38	MY 63S4	132
0.15		9479	10300	TKA	68 / TRF38	MY 63S4	132	
0.17		8173	10300	TKAF	68 / TRF38	MY 63S4	132	
0.19		7259	10300					
0.21		6462	10300					
0.24		5648	10300					
0.28		4846	10300					
0.32		4329	10300					
0.37		3750	10300					
0.42		3315	10300					
0.47		2917	10300					
0.55		2532	10300					
0.62		2244	10300					
0.70		1981	10300					
0.79		1739	10300	TK	68 / TRF38	MY 63S4	132	
0.90		1535	10300	TKF	68 / TRF38	MY 63S4	132	
1.0		1351	10300	TKA	68 / TRF38	MY 63S4	132	
				TKAF	68 / TRF38	MY 63S4	132	
1.1		1171	10300	TK	68 / TRF38	MY 63M4	132	
1.3		1034	10300	TKF	68 / TRF38	MY 63M4	132	
1.5		903	10300	TKA	68 / TRF38	MY 63M4	132	
1.7		793	10300	TKAF	68 / TRF38	MY 63M4	132	
1.9		697	10300	TK	68 / TRF38	MY 63L4	132	
2.1		613	10300	TKF	68 / TRF38	MY 63L4	132	
2.4		542	10300	TKA	68 / TRF38	MY 63L4	132	
				TKAF	68 / TRF38	MY 63L4	132	
2.9		471	10300	TK	68 / TRF38	MY 71D4	132	
3.3		420	10300	TKF	68 / TRF38	MY 71D4	132	
				TKA	68 / TRF38	MY 71D4	132	
				TKAF	68 / TRF38	MY 71D4	132	
3.8		361	10300	TK	68 / TRF38	MY 80K4	132	
4.2		323	10300	TKF	68 / TRF38	MY 80K4	132	
4.9		279	10300	TKA	68 / TRF38	MY 80K4	132	
5.5	246	10300	TKAF	68 / TRF38	MY 80K4	132		
6.4	217	10300	TK	68 / TRF38	MY 80N4	132		
7.2	191	10300	TKF	68 / TRF38	MY 80N4	132		
			TKA	68 / TRF38	MY 80N4	132		
			TKAF	68 / TRF38	MY 80N4	132		
<b>1550</b>	0.09	15310	15400	TK	78 / TRF38	MY 63S4	132	
	0.10	14043	15400	TKF	78 / TRF38	MY 63S4	132	
	0.12	11955	15400	TKA	78 / TRF38	MY 63S4	132	
	0.14	10217	15400	TKAF	78 / TRF38	MY 63S4	132	
	0.16	8809	15400					

$M_{2 \max}$ [Nm]	$n_2$ [r/min]	$i$	$F_{r2}$ [N]				Page
<b>1550</b>	0.18	7528	15400	TK	78 / TRF38	MY 63S4	132
	0.21	6606	15400	TKF	78 / TRF38	MY 63S4	132
	0.24	5774	15400	TKA	78 / TRF38	MY 63S4	132
	0.27	5089	15400	TKAF	78 / TRF38	MY 63S4	132
	0.31	4489	15400				
	0.35	3961	15400				
	0.40	3485	15400				
	0.48	2901	15400				
	0.51	2717	15400				
	0.56	2370	15400	TK	78 / TRF38	MY 63M4	132
				TKF	78 / TRF38	MY 63M4	132
				TKA	78 / TRF38	MY 63M4	132
				TKAF	78 / TRF38	MY 63M4	132
	0.64	2050	15400	TK	78 / TRF38	MY 63M4	132
	0.75	1772	15400	TKF	78 / TRF38	MY 63M4	132
	0.87	1514	15400	TKA	78 / TRF38	MY 63M4	132
				TKAF	78 / TRF38	MY 63M4	132
	0.94	1388	15400	TK	78 / TRF38	MY 63L4	132
	1.1	1218	15400	TKF	78 / TRF38	MY 63L4	132
	1.2	1053	15400	TKA	78 / TRF38	MY 63L4	132
				TKAF	78 / TRF38	MY 63L4	132
	1.5	924	15400	TK	78 / TRF38	MY 71D4	132
	1.7	815	15400	TKF	78 / TRF38	MY 71D4	132
	1.9	709	15400	TKA	78 / TRF38	MY 71D4	132
				TKAF	78 / TRF38	MY 71D4	132
	2.2	622	15400	TK	78 / TRF38	MY 80K4	132
	2.5	552	15400	TKF	78 / TRF38	MY 80K4	132
	2.8	485	15400	TKA	78 / TRF38	MY 80K4	132
				TKAF	78 / TRF38	MY 80K4	132
	3.2	428	15400	TK	78 / TRF38	MY 80N4	132
	3.8	367	15400	TKF	78 / TRF38	MY 80N4	132
				TKA	78 / TRF38	MY 80N4	132
				TKAF	78 / TRF38	MY 80N4	132
4.3	328	15400	TK	78 / TRF38	MY 90S4	132	
4.8	290	15400	TKF	78 / TRF38	MY 90S4	132	
5.5	252	15400	TKA	78 / TRF38	MY 90S4	132	
			TKAF	78 / TRF38	MY 90S4	132	
<b>2700</b>	0.09	14829	27300	TK	88 / TRF58	MY 63S4	132
	0.10	13168	27300	TKF	88 / TRF58	MY 63S4	132
	0.12	11737	27300	TKA	88 / TRF58	MY 63S4	132
	0.14	10217	27300	TKAF	88 / TRF58	MY 63S4	132
	0.15	9073	27300				
	0.18	7854	27300				
	0.20	6832	27300				
	0.23	5930	27300				
	0.26	5240	27300				
	0.30	4562	27300				
	0.33	4037	27300	TK	88 / TRF58	MY 63M4	132
	0.37	3609	27300	TKF	88 / TRF58	MY 63M4	132
	0.42	3107	27300	TKA	88 / TRF58	MY 63M4	132
	0.48	2728	27300	TKAF	88 / TRF58	MY 63M4	132
	0.55	2371	27300	TK	88 / TRF58	MY 63L4	132
				TKF	88 / TRF58	MY 63L4	132
				TKA	88 / TRF58	MY 63L4	132
				TKAF	88 / TRF58	MY 63L4	132



$M_{2\ max}$ [Nm]	$n_2$ [r/min]	$i$	$F_{r_2}$ [N]				Page	
<b>2700</b>	0.62	2088	27300	TK	88 / TRF58	MY 63L4	132	
	0.70	1854	27300	TKF	88 / TRF58	MY 63L4	132	
				TKA	88 / TRF58	MY 63L4	132	
				TKAF	88 / TRF58	MY 63L4	132	
	0.83	1657	27300	TK	88 / TRF58	MY 71D4	132	
	0.97	1415	27300	TKF	88 / TRF58	MY 71D4	132	
	1.1	1229	27300	TKA	88 / TRF58	MY 71D4	132	
				TKAF	88 / TRF58	MY 71D4	132	
	1.3	1078	27300	TK	88 / TRF58	MY 80K4	132	
	1.4	951	27300	TKF	88 / TRF58	MY 80K4	132	
	1.6	837	27300	TKA	88 / TRF58	MY 80K4	132	
				TKAF	88 / TRF58	MY 80K4	132	
	1.9	726	27300	TK	88 / TRF58	MY 80N4	132	
	2.2	638	27300	TKF	88 / TRF58	MY 80N4	132	
				TKA	88 / TRF58	MY 80N4	132	
				TKAF	88 / TRF58	MY 80N4	132	
	2.5	562	27300	TK	88 / TRF58	MY 90S4	132	
	3.0	474	27300	TKF	88 / TRF58	MY 90S4	132	
	3.3	426	27300	TKA	88 / TRF58	MY 90S4	132	
				TKAF	88 / TRF58	MY 90S4	132	
	3.8	373	27300	TK	88 / TRF58	MY 90L4	132	
	4.3	330	27300	TKF	88 / TRF58	MY 90L4	132	
	4.8	294	27300	TKA	88 / TRF58	MY 90L4	132	
				TKAF	88 / TRF58	MY 90L4	132	
	5.6	250	27300	TK	88 / TRF58	MY 100M4	132	
	6.0	236	27300	TKF	88 / TRF58	MY 100M4	132	
	7.0	201	27300	TKA	88 / TRF58	MY 100M4	132	
				TKAF	88 / TRF58	MY 100M4	132	
	<b>4300</b>	0.08	18091	40000	TK	98 / TRF58	MY 63S4	132
		0.08	16666	40000	TKF	98 / TRF58	MY 63S4	132
		0.09	14897	40000	TKA	98 / TRF58	MY 63S4	132
		0.10	13182	40000	TKAF	98 / TRF58	MY 63S4	132
		0.12	11677	40000				
		0.13	10317	40000				
		0.15	9083	40000				
		0.17	8054	40000				
0.20		6970	40000					
0.22		6027	40000	TK	98 / TRF58	MY 63M4	132	
0.24		5391	40000	TKF	98 / TRF58	MY 63M4	132	
0.28		4669	40000	TKA	98 / TRF58	MY 63M4	132	
0.32		4082	40000	TKAF	98 / TRF58	MY 63M4	132	
0.36		3583	40000	TK	98 / TRF58	MY 63L4	132	
0.42		3108	40000	TKF	98 / TRF58	MY 63L4	132	
				TKA	98 / TRF58	MY 63L4	132	
				TKAF	98 / TRF58	MY 63L4	132	
0.50		2757	40000	TK	98 / TRF58	MY 71D4	132	
				TKF	98 / TRF58	MY 71D4	132	
				TKA	98 / TRF58	MY 71D4	132	
				TKAF	98 / TRF58	MY 71D4	132	
0.57		2419	40000	TK	98 / TRF58	MY 71D4	132	
0.65		2123	40000	TKF	98 / TRF58	MY 71D4	132	
				TKA	98 / TRF58	MY 71D4	132	
				TKAF	98 / TRF58	MY 71D4	132	
0.73		1856	40000	TK	98 / TRF58	MY 80K4	132	
0.84	1625	40000	TKF	98 / TRF58	MY 80K4	132		
0.95	1430	40000	TKA	98 / TRF58	MY 80K4	132		
1.1	1261	40000	TKAF	98 / TRF58	MY 80K4	132		





$M_2 \text{ max}$ [Nm]	$n_2$ [r/min]	$i$	$Fr_2$ [N]				Page
<b>4300</b>	1.2	1102	40000	TK	98 / TRF58	MY 80N4	132
	1.4	957	40000	TKF	98 / TRF58	MY 80N4	132
				TKA	98 / TRF58	MY 80N4	132
				TKAF	98 / TRF58	MY 80N4	132
	1.6	855	40000	TK	98 / TRF58	MY 90S4	132
	1.9	743	40000	TKF	98 / TRF58	MY 90S4	132
	2.1	652	40000	TKA	98 / TRF58	MY 90S4	132
				TKAF	98 / TRF58	MY 90S4	132
	2.5	573	40000	TK	98 / TRF58	MY 90L4	132
	2.8	504	40000	TKF	98 / TRF58	MY 90L4	132
				TKA	98 / TRF58	MY 90L4	132
				TKAF	98 / TRF58	MY 90L4	132
	3.2	437	40000	TK	98 / TRF58	MY 100M4	132
	3.7	382	40000	TKF	98 / TRF58	MY 100M4	132
	4.1	342	40000	TKA	98 / TRF58	MY 100M4	132
				TKAF	98 / TRF58	MY 100M4	132
	4.6	305	40000	TK	98 / TRF58	MY 100L4	132
	5.4	258	40000	TKF	98 / TRF58	MY 100L4	132
	6.0	232	40000	TKA	98 / TRF58	MY 100L4	132
				TKAF	98 / TRF58	MY 100L4	132
	7.1	199	40000	TK	98 / TRF58	MY 112M4	132
				TKF	98 / TRF58	MY 112M4	132
				TKA	98 / TRF58	MY 112M4	132
				TKAF	98 / TRF58	MY 112M4	132
<b>8000</b>	0.10	14311	65000	TK	108 / TRF78	MY 63S4	132
	0.11	12211	65000	TKF	108 / TRF78	MY 63S4	132
				TKA	108 / TRF78	MY 63S4	132
				TKAF	108 / TRF78	MY 63S4	132
	0.12	10677	65000	TK	108 / TRF78	MY 63M4	132
	0.14	9524	65000	TKF	108 / TRF78	MY 63M4	132
	0.16	8328	65000	TKA	108 / TRF78	MY 63M4	132
				TKAF	108 / TRF78	MY 63M4	132
	0.18	7270	65000	TK	108 / TRF78	MY 63L4	132
	0.21	6184	65000	TKF	108 / TRF78	MY 63L4	132
	0.23	5662	65000	TKA	108 / TRF78	MY 63L4	132
				TKAF	108 / TRF78	MY 63L4	132
	0.27	5138	65000	TK	108 / TRF78	MY 71D4	132
	0.32	4359	65000	TKF	108 / TRF78	MY 71D4	132
	0.36	3810	65000	TKA	108 / TRF78	MY 71D4	132
				TKAF	108 / TRF78	MY 71D4	132
	0.41	3358	65000	TK	108 / TRF78	MY 80K4	132
	0.46	2977	65000	TKF	108 / TRF78	MY 80K4	132
	0.52	2599	65000	TKA	108 / TRF78	MY 80K4	132
				TKAF	108 / TRF78	MY 80K4	132
0.60	2286	65000	TK	108 / TRF78	MY 80N4	132	
0.71	1939	65000	TKF	108 / TRF78	MY 80N4	132	
			TKA	108 / TRF78	MY 80N4	132	
			TKAF	108 / TRF78	MY 80N4	132	
0.82	1713	65000	TK	108 / TRF78	MY 90S4	132	
0.90	1554	65000	TKF	108 / TRF78	MY 90S4	132	
1.1	1336	65000	TKA	108 / TRF78	MY 90S4	132	
			TKAF	108 / TRF78	MY 90S4	132	
1.2	1166	65000	TK	108 / TRF78	MY 90L4	132	
1.4	1030	65000	TKF	108 / TRF78	MY 90L4	132	
1.6	904	65000	TKA	108 / TRF78	MY 90L4	132	
			TKAF	108 / TRF78	MY 90L4	132	



$M_{2\ max}$ [Nm]	$n_2$ [r/min]	$i$	$F_{r_2}$ [N]				Page	
<b>8000</b>	1.8	793	65000	TK	108 / TRF78	MY 100M4	132	
	2.0	696	65000	TKF	108 / TRF78	MY 100M4	132	
	2.3	615	65000	TKA	108 / TRF78	MY 100M4	132	
				TKAF	108 / TRF78	MY 100M4	132	
	2.7	522	65000	TK	108 / TRF78	MY 100L4	132	
	3.0	461	65000	TKF	108 / TRF78	MY 100L4	132	
				TKA	108 / TRF78	MY 100L4	132	
				TKAF	108 / TRF78	MY 100L4	132	
	3.5	408	65000	TK	108 / TRF78	MY 112M4	132	
	3.9	364	65000	TKF	108 / TRF78	MY 112M4	132	
				TKA	108 / TRF78	MY 112M4	132	
				TKAF	108 / TRF78	MY 112M4	132	
	4.5	318	65000	TK	108 / TRF78	MY 132S4	132	
	5.0	286	65000	TKF	108 / TRF78	MY 132S4	132	
	5.7	251	65000	TKA	108 / TRF78	MY 132S4	132	
				TKAF	108 / TRF78	MY 132S4	132	
	<b>13000</b>	0.08	17550	79200	TK	128 / TRF78	MY 63M4	132
		0.08	16006	79200	TKF	128 / TRF78	MY 63M4	132
0.09		14975	79200	TKA	128 / TRF78	MY 63M4	132	
0.11		12440	79200	TKAF	128 / TRF78	MY 63M4	132	
0.12		10915	79200	TK	128 / TRF78	MY 63L4	132	
0.13		9819	79200	TKF	128 / TRF78	MY 63L4	132	
				TKA	128 / TRF78	MY 63L4	132	
				TKAF	128 / TRF78	MY 63L4	132	
0.16		8443	79200	TK	128 / TRF78	MY 71D4	132	
0.18		7482	79200	TKF	128 / TRF78	MY 71D4	132	
0.21		6565	79200	TKA	128 / TRF78	MY 71D4	132	
				TKAF	128 / TRF78	MY 71D4	132	
0.23		5804	79200	TK	128 / TRF78	MY 80K4	132	
0.27		5027	79200	TKF	128 / TRF78	MY 80K4	132	
0.31		4423	79200	TKA	128 / TRF78	MY 80K4	132	
0.35		3889	79200	TKAF	128 / TRF78	MY 80K4	132	
0.42		3311	79200	TK	128 / TRF78	MY 80N4	132	
0.46		3009	79200	TKF	128 / TRF78	MY 80N4	132	
				TKA	128 / TRF78	MY 80N4	132	
				TKAF	128 / TRF78	MY 80N4	132	
0.54		2607	79200	TK	128 / TRF78	MY 90S4	132	
0.62		2268	79200	TKF	128 / TRF78	MY 90S4	132	
				TKA	128 / TRF78	MY 90S4	132	
				TKAF	128 / TRF78	MY 90S4	132	
0.73		1926	79200	TK	128 / TRF78	MY 90S4	132	
				TKF	128 / TRF78	MY 90S4	132	
				TKA	128 / TRF78	MY 90S4	132	
				TKAF	128 / TRF78	MY 90S4	132	
0.80		1757	79200	TK	128 / TRF78	MY 90L4	132	
0.91		1541	79200	TKF	128 / TRF78	MY 90L4	132	
			TKA	128 / TRF78	MY 90L4	132		
			TKAF	128 / TRF78	MY 90L4	132		
1.1	1342	79200	TK	128 / TRF78	MY 100M4	132		
1.2	1177	79200	TKF	128 / TRF78	MY 100M4	132		
1.4	1025	79200	TKA	128 / TRF78	MY 100M4	132		
			TKAF	128 / TRF78	MY 100M4	132		
1.6	899	79200	TK	128 / TRF78	MY 100L4	132		
1.8	790	79200	TKF	128 / TRF78	MY 100L4	132		
2.0	704	79200	TKA	128 / TRF78	MY 100L4	132		
			TKAF	128 / TRF78	MY 100L4	132		



$M_2 \text{ max}$ [Nm]	$n_2$ [r/min]	$i$	$F_{r2}$ [N]				Page
<b>13000</b>	2.3	610	79200	TK	128 / TRF78	MY 112M4	132
	2.6	549	79200	TKF	128 / TRF78	MY 112M4	132
				TKA	128 / TRF78	MY 112M4	132
				TKAF	128 / TRF78	MY 112M4	132
	3.0	477	79200	TK	128 / TRF78	MY 132S4	132
	3.4	418	79200	TKF	128 / TRF78	MY 132S4	132
				TKA	128 / TRF78	MY 132S4	132
				TKAF	128 / TRF78	MY 132S4	132
	2.6	536	79200	TK	128 / TRF88	MY 112M4	132
				TKF	128 / TRF88	MY 112M4	132
				TKA	128 / TRF88	MY 112M4	132
				TKAF	128 / TRF88	MY 112M4	132
	3.0	473	79200	TK	128 / TRF88	MY 132S4	132
	3.4	418	79200	TKF	128 / TRF88	MY 132S4	132
				TKA	128 / TRF88	MY 132S4	132
				TKAF	128 / TRF88	MY 132S4	132
	3.9	367	79200	TK	128 / TRF88	MY 132M4	132
	4.3	330	79200	TKF	128 / TRF88	MY 132M4	132
	5.0	287	79200	TKA	128 / TRF88	MY 132M4	132
				TKAF	128 / TRF88	MY 132M4	132
	5.7	253	79200	TK	128 / TRF88	MY 132ML4	132
				TKF	128 / TRF88	MY 132ML4	132
				TKA	128 / TRF88	MY 132ML4	132
				TKAF	128 / TRF88	MY 132ML4	132
<b>18000</b>	0.08	17679	112200	TK	158 / TRF98	MY 80K4	132
	0.09	15729	112200	TKF	158 / TRF98	MY 80K4	132
	0.09	14721	112200	TKA	158 / TRF98	MY 80K4	132
	0.10	13097	112200	TKAF	158 / TRF98	MY 80K4	132
	0.12	11368	112200				
	0.13	10114	112200				
	0.16	8718	112200				
	0.18	7734	112200				
	0.28	5074	112200	TK	158 / TRF98	MY 90S4	132
	0.31	4514	112200	TKF	158 / TRF98	MY 90S4	132
	0.35	3979	112200	TKA	158 / TRF98	MY 90S4	132
	0.40	3516	112200	TKAF	158 / TRF98	MY 90S4	132
	0.46	3051	112200				
	0.54	2610	112200	TK	158 / TRF98	MY 90L4	132
	0.61	2322	112200	TKF	158 / TRF98	MY 90L4	132
				TKA	158 / TRF98	MY 90L4	132
				TKAF	158 / TRF98	MY 90L4	132
	0.70	2029	112200	TK	158 / TRF98	MY 100M4	132
	0.78	1805	112200	TKF	158 / TRF98	MY 100M4	132
				TKA	158 / TRF98	MY 100M4	132
				TKAF	158 / TRF98	MY 100M4	132
	0.85	1659	112200	TK	158 / TRF98	MY 100M4	132
	1.0	1365	112200	TKF	158 / TRF98	MY 100M4	132
				TKA	158 / TRF98	MY 100M4	132
			TKAF	158 / TRF98	MY 100M4	132	
1.1	1229	112200	TK	158 / TRF98	MY 100L4	132	
1.3	1093	112200	TKF	158 / TRF98	MY 100L4	132	
			TKA	158 / TRF98	MY 100L4	132	
			TKAF	158 / TRF98	MY 100L4	132	
1.5	942	112200	TK	158 / TRF98	MY 112M4	132	
1.7	854	112200	TKF	158 / TRF98	MY 112M4	132	
1.9	756	112200	TKA	158 / TRF98	MY 112M4	132	
			TKAF	158 / TRF98	MY 112M4	132	



$M_{2\ max}$ [Nm]	$n_2$ [r/min]	$i$	$F_{r_2}$ [N]	 		Page
<b>18000</b>	2.2	661	112200	TK 158 / TRF98	MY 132S4	132
	2.5	567	112200	TKF 158 / TRF98	MY 132S4	132
				TKA 158 / TRF98	MY 132S4	132
				TKAF 158 / TRF98	MY 132S4	132
	2.8	504	112200	TK 158 / TRF98	MY 132M4	132
	3.3	434	112200	TKF 158 / TRF98	MY 132M4	132
				TKA 158 / TRF98	MY 132M4	132
				TKAF 158 / TRF98	MY 132M4	132
	3.8	379	112200	TK 158 / TRF98	MY 132ML4	132
	4.3	333	112200	TKF 158 / TRF98	MY 132ML4	132
				TKA 158 / TRF98	MY 132ML4	132
				TKAF 158 / TRF98	MY 132ML4	132
	5.0	291	112200	TK 158 / TRF98	MY 160M4	132
				TKF 158 / TRF98	MY 160M4	132
				TKA 158 / TRF98	MY 160M4	132
				TKAF 158 / TRF98	MY 160M4	132
	3.7	385	112200	TK 158 / TRF108	MY 132ML4	132
	4.4	325	112200	TKF 158 / TRF108	MY 132ML4	132
				TKA 158 / TRF108	MY 132ML4	132
				TKAF 158 / TRF108	MY 132ML4	132
	4.8	299	112200	TK 158 / TRF108	MY 160M4	132
				TKF 158 / TRF108	MY 160M4	132
				TKA 158 / TRF108	MY 160M4	132
				TKAF 158 / TRF108	MY 160M4	132
5.8	253	112200	TK 158 / TRF108	MY 160L4	132	
6.3	230	112200	TKF 158 / TRF108	MY 160L4	132	
6.9	213	112200	TKA 158 / TRF108	MY 160L4	132	
			TKAF 158 / TRF108	MY 160L4	132	
<b>32000</b>	0.07	19723	150000	TK 168 / TRF98	MY 80K4	132
	0.08	17406	150000	TKH 168 / TRF98	MY 80K4	132
	0.09	15000	150000			
	0.10	13238	150000			
	0.12	11573	150000			
	0.13	10264	150000			
	0.16	8628	150000	TK 168 / TRF98	MY 80N4	132
				TKH 168 / TRF98	MY 80N4	132
	0.21	6562	150000	TK 168 / TRF98	MY 90S4	132
	0.26	5355	150000	TKH 168 / TRF98	MY 90S4	132
	0.29	4788	150000	TK 168 / TRF98	MY 90L4	132
	0.35	4079	150000	TKH 168 / TRF98	MY 90L4	132
	0.42	3376	150000	TK 168 / TRF98	MY 100M4	132
	0.51	2755	150000	TKH 168 / TRF98	MY 100M4	132
	0.62	2263	150000	TK 168 / TRF98	MY 100L4	132
				TKH 168 / TRF98	MY 100L4	132
	0.64	2182	150000	TK 168 / TRF98	MY 100L4	132
				TKH 168 / TRF98	MY 100L4	132
	0.83	1704	150000	TK 168 / TRF98	MY 112M4	132
	1.0	1408	150000	TKH 168 / TRF98	MY 112M4	132
	1.1	1296	150000	TK 168 / TRF98	MY 132S4	132
	1.3	1101	150000	TKH 168 / TRF98	MY 132S4	132
	1.5	944	150000	TK 168 / TRF98	MY 132M4	132
	1.7	843	150000	TKH 168 / TRF98	MY 132M4	132
1.9	757	150000				
2.3	632	150000	TK 168 / TRF98	MY 132ML4	132	
			TKH 168 / TRF98	MY 132ML4	132	
2.6	561	150000	TK 168 / TRF98	MY 160M4	132	
3.0	481	150000	TKH 168 / TRF98	MY 160M4	132	

$M_{2 \max}$ [Nm]	$n_2$ [r/min]	$i$	$F_{r2}$ [N]				Page
<b>32000</b>	3.5	423	150000	TK	168 / TRF98	MY 160L4	132
	4.0	369	150000	TKH	168 / TRF98	MY 160L4	132
	4.6	318	150000	TK	168 / TRF108	MY 180M4	132
				TKH	168 / TRF108	MY 180M4	132
	5.3	278	150000	TK	168 / TRF108	MY 180L4	132
				TKH	168 / TRF108	MY 180L4	132
	6.0	244	150000	TK	168 / TRF108	MY 200L4	132
				TKH	168 / TRF108	MY 200L4	132
	6.9	213	150000	TK	168 / TRF108	MY 200L4	132
				TKH	168 / TRF108	MY 200L4	132
	7.1	206	150000	TK	168 / TRF108	MY 225S4	132
				TKH	168 / TRF108	MY 225S4	132
	8.2	180	150000	TK	168 / TRF108	MY 225M4	132
				TKH	168 / TRF108	MY 225M4	132
9.2	160	150000	TK	168 / TRF108	MY 225M4	132	
			TKH	168 / TRF108	MY 225M4	132	
<b>50000</b>	0.04	32625	189900	TK	188 / TRF98	MY 80K4	132
	0.05	27165	189900	TKH	188 / TRF98	MY 80K4	132
	0.06	24353	189900				
	0.07	19144	189900				
	0.08	16978	189900				
	0.10	14272	189900	TK	188 / TRF98	MY 80N4	132
				TKH	188 / TRF98	MY 80N4	132
	0.11	13116	189900	TK	188 / TRF98	MY 90S4	132
				TKH	188 / TRF98	MY 90S4	132
	0.12	11647	189900	TK	188 / TRF98	MY 90S4	132
				TKH	188 / TRF98	MY 90S4	132
	0.13	10413	189900	TK	188 / TRF98	MY 90L4	132
				TKH	188 / TRF98	MY 90L4	132
	0.15	9363	189900	TK	188 / TRF98	MY 100M4	132
TKH				188 / TRF98	MY 100M4	132	
0.17	8126	189900	TK	188 / TRF98	MY 100L4	132	
			TKH	188 / TRF98	MY 100L4	132	
0.19	7343	189900	TK	188 / TRF98	MY 112M4	132	
			TKH	188 / TRF98	MY 112M4	132	
0.21	6747	189900	TK	188 / TRF98	MY 132S4	132	
			TKH	188 / TRF98	MY 132S4	132	
0.24	5991	189900	TK	188 / TRF98	MY 132M4	132	
			TKH	188 / TRF98	MY 132M4	132	
0.26	5358	189900	TK	188 / TRF98	MY 132ML4	132	
			TKH	188 / TRF98	MY 132ML4	132	
0.29	4817	189900	TK	188 / TRF98	MY 160L4	132	
			TKH	188 / TRF98	MY 160L4	132	
0.32	4370	189900	TK	188 / TRF98	MY 180M4	132	
			TKH	188 / TRF98	MY 180M4	132	
0.39	3609	189900	TK	188 / TRF98	MY 180M4	132	
			TKH	188 / TRF98	MY 180M4	132	
0.46	3062	189900	TK	188 / TRF98	MY 200L4	132	
			TKH	188 / TRF98	MY 200L4	132	
0.56	2519	189900	TK	188 / TRF98	MY 225S4	132	
			TKH	188 / TRF98	MY 225S4	132	
0.63	2268	189900	TK	188 / TRF98	MY 225M4	132	
			TKH	188 / TRF98	MY 225M4	132	
0.69	2054	189900	TK	188 / TRF98	MY 225M4	132	
			TKH	188 / TRF98	MY 225M4	132	
0.79	1821	189900	TK	188 / TRF98	MY 160M4	132	
			TKH	188 / TRF98	MY 160M4	132	
0.89	1605	189900	TK	188 / TRF98	MY 160M4	132	
			TKH	188 / TRF98	MY 160M4	132	
1.0	1395	189900	TK	188 / TRF98	MY 160L4	132	
			TKH	188 / TRF98	MY 160L4	132	
1.2	1196	189900	TK	188 / TRF98	MY 180M4	132	
			TKH	188 / TRF98	MY 180M4	132	
1.4	1046	189900	TK	188 / TRF98	MY 200L4	132	
			TKH	188 / TRF98	MY 200L4	132	
1.5	945	189900	TK	188 / TRF98	MY 225S4	132	
			TKH	188 / TRF98	MY 225S4	132	
2.0	738	189900	TK	188 / TRF98	MY 225M4	132	
			TKH	188 / TRF98	MY 225M4	132	
2.4	621	189900	TK	188 / TRF98	MY 225M4	132	
			TKH	188 / TRF98	MY 225M4	132	
2.8	527	189900	TK	188 / TRF98	MY 160M4	132	
			TKH	188 / TRF98	MY 160M4	132	
1.7	835	189900	TK	188 / TRF108	MY 160M4	132	
			TKH	188 / TRF108	MY 160M4	132	
2.0	729	189900	TK	188 / TRF108	MY 160L4	132	
			TKH	188 / TRF108	MY 160L4	132	
2.4	622	189900	TK	188 / TRF108	MY 180M4	132	
			TKH	188 / TRF108	MY 180M4	132	
2.8	520	189900	TK	188 / TRF108	MY 180M4	132	
			TKH	188 / TRF108	MY 180M4	132	
3.2	454	189900	TK	188 / TRF108	MY 200L4	132	
			TKH	188 / TRF108	MY 200L4	132	
4.1	355	189900	TK	188 / TRF108	MY 200L4	132	
			TKH	188 / TRF108	MY 200L4	132	
5.6	261	189900	TK	188 / TRF108	MY 225S4	132	
			TKH	188 / TRF108	MY 225S4	132	
6.6	221	189900	TK	188 / TRF108	MY 225M4	132	
			TKH	188 / TRF108	MY 225M4	132	
7.6	193	189900	TK	188 / TRF108	MY 225M4	132	
			TKH	188 / TRF108	MY 225M4	132	
9.0	163	189900	TK	188 / TRF108	MY 225M4	132	
			TKH	188 / TRF108	MY 225M4	132	





**TKF38..**

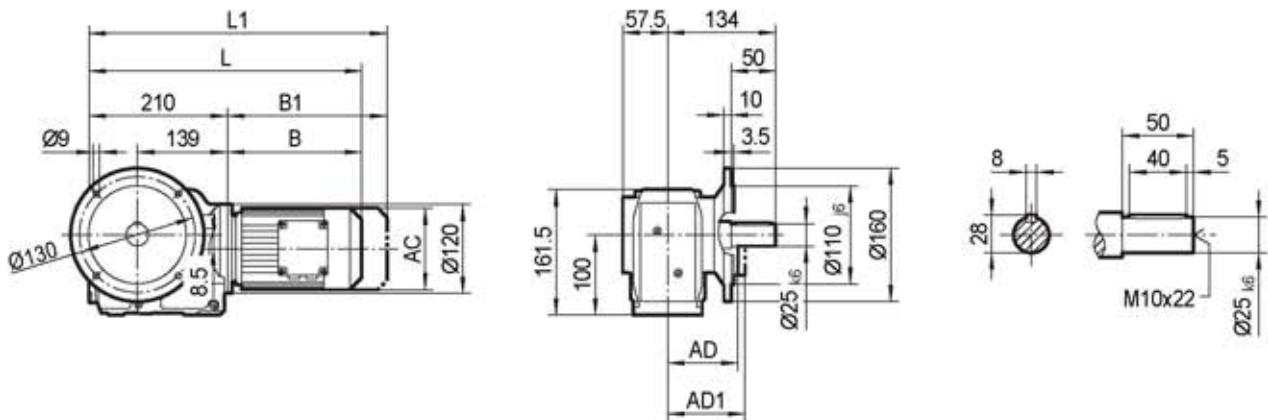

**TKAF38..**

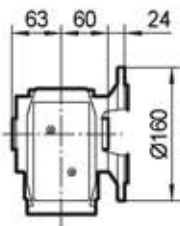

**TKHF38..**

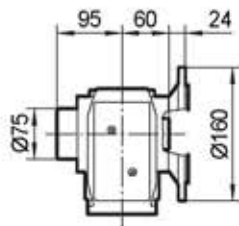

**TKVF38..**

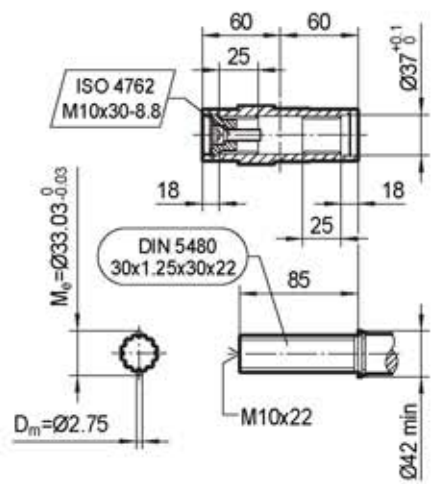
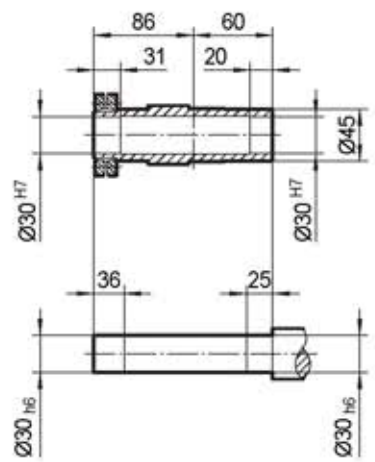
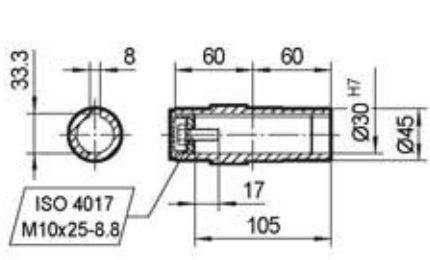
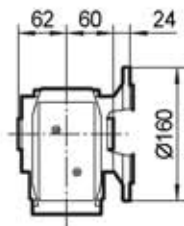

	MY63..	MY71D	MY80..	MY90..	MY100M	MY100L				
AC	132	145	145	197	197	197				
AD	105	122	122	154	166	166				
AD1	105	127	127	161	166	166				
B	191	206	256	276	328	358				
B1	246	269	319	361	413	443				
L	401	416	466	486	538	568				
L1	456	479	529	571	623	653				

**TKA38..**

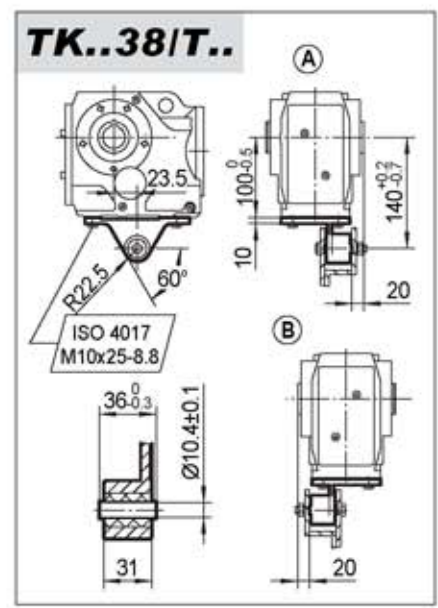
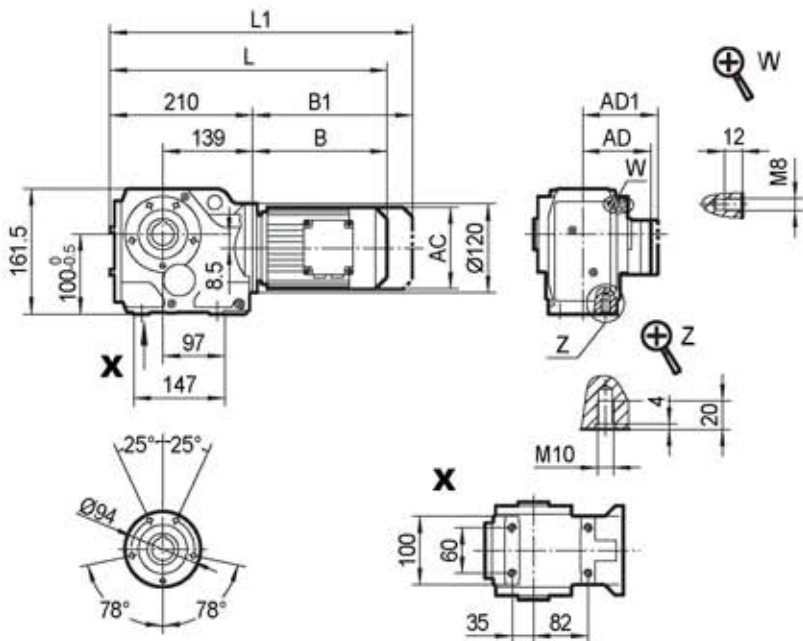

**TKA38..**

**TKH38..**

**TKV38..**

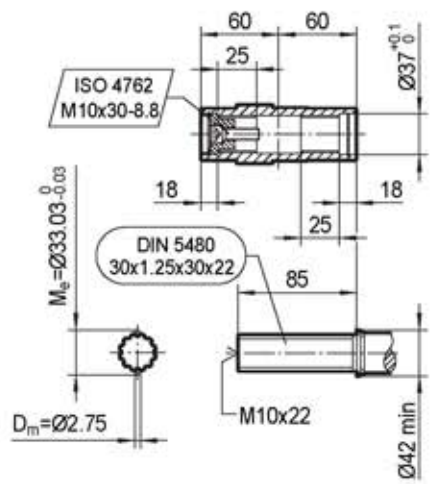
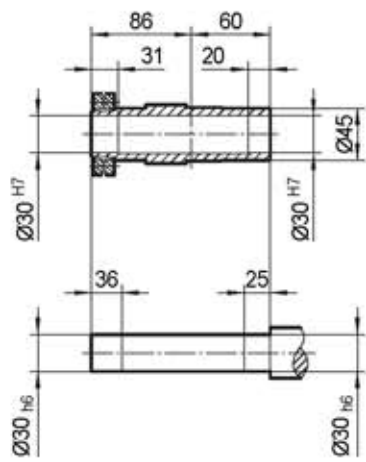
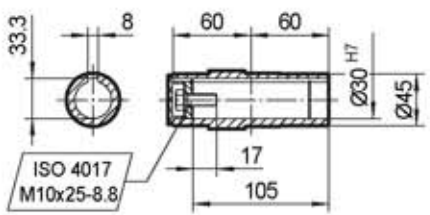
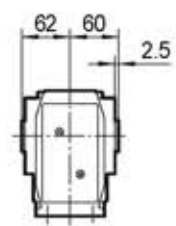
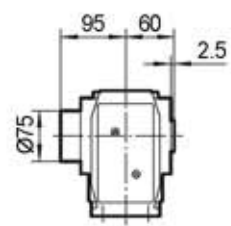
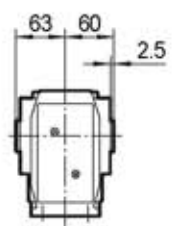

	MY63..	MY71D	MY80..	MY90..	MY100M	MY100L			
AC	132	145	145	197	197	197			
AD	105	122	122	154	166	166			
AD1	105	127	127	161	166	166			
B	191	206	256	276	328	358			
B1	246	269	319	361	413	443			
L	401	416	466	486	538	568			
L1	456	479	529	571	623	653			

**TKAZ38..**

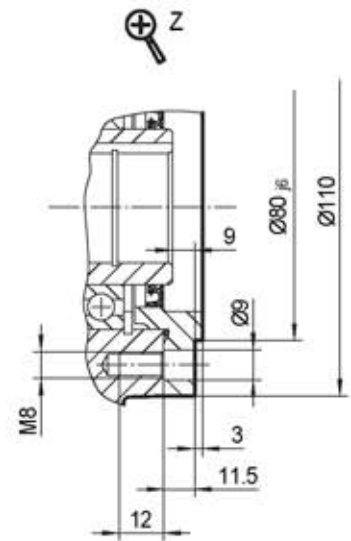
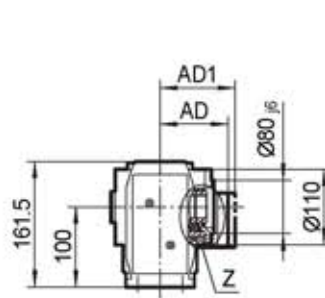
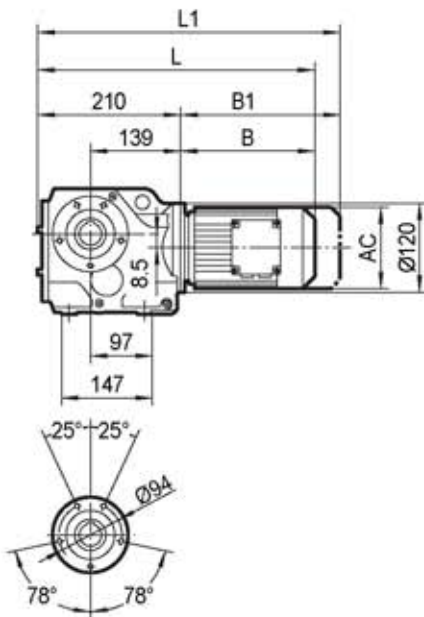

**TKAZ38..**

**TKHZ38..**

**TKVZ38..**

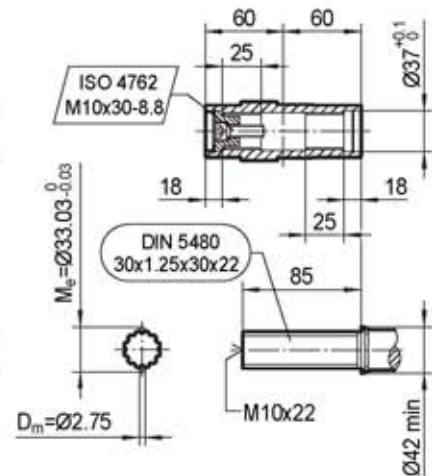
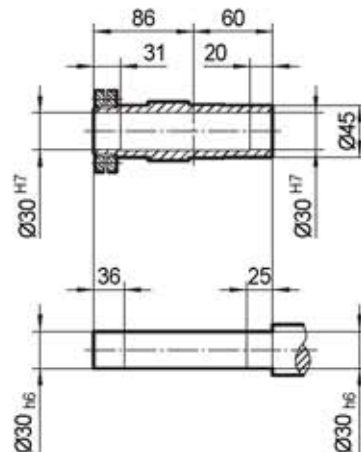
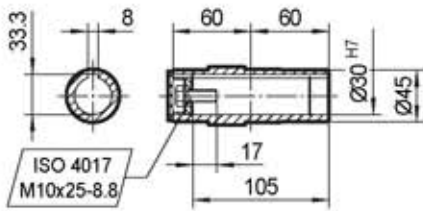
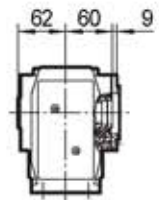
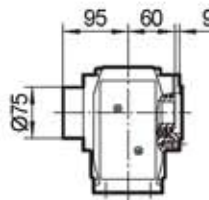
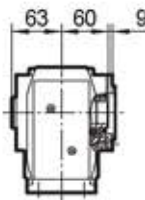

	MY63..	MY71D	MY80..	MY90..	MY100M	MY100L				
AC	132	145	145	197	197	197				
AD	105	122	122	154	166	166				
AD1	105	127	127	161	166	166				
B	191	206	256	276	328	358				
B1	246	269	319	361	413	443				
L	401	416	466	486	538	568				
L1	456	479	529	571	623	653				



**TK48..**

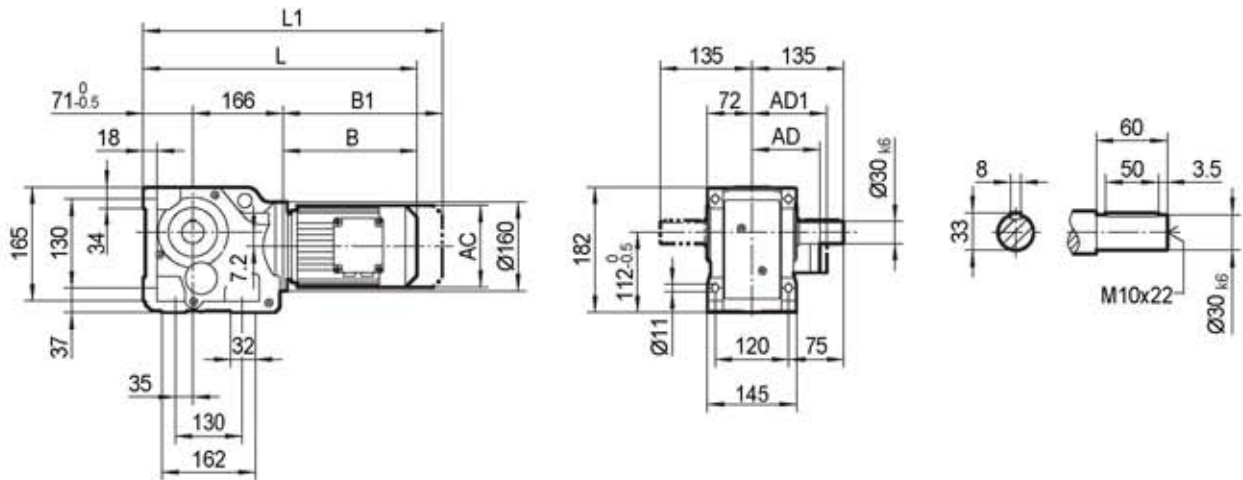

**TKA48B..**

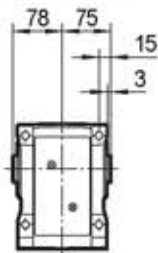

**TKH48B..**

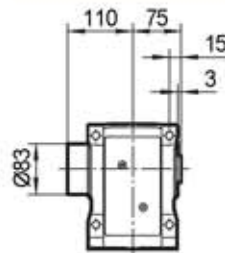

**TKV48B..**

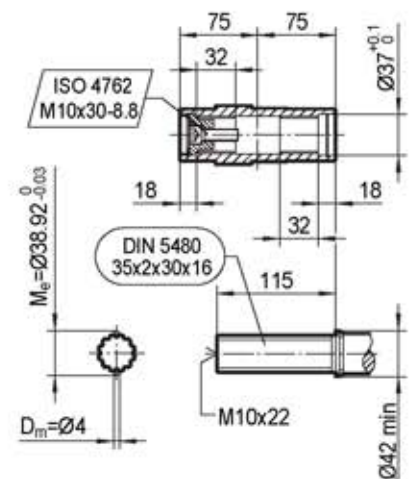
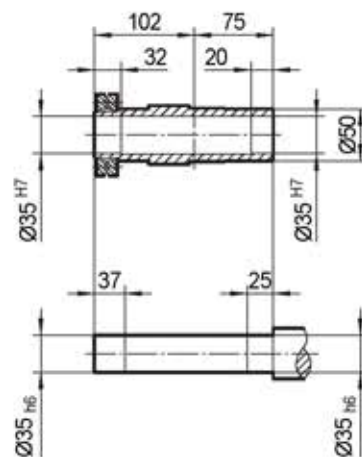
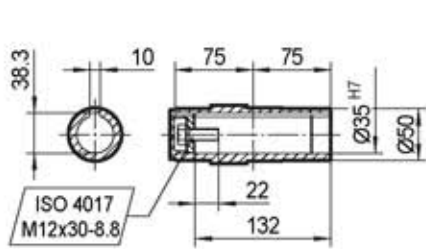
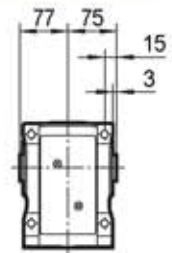

	MY63..	MY71D	MY80..	MY90..	MY100M	MY100L				
AC	132	145	145	197	197	197				
AD	105	122	122	154	166	166				
AD1	105	127	127	161	166	166				
B	185	199	249	269	319	349				
B1	240	263	313	354	404	434				
L	422	436	486	506	556	586				
L1	477	500	550	591	641	671				

**TKF48..**

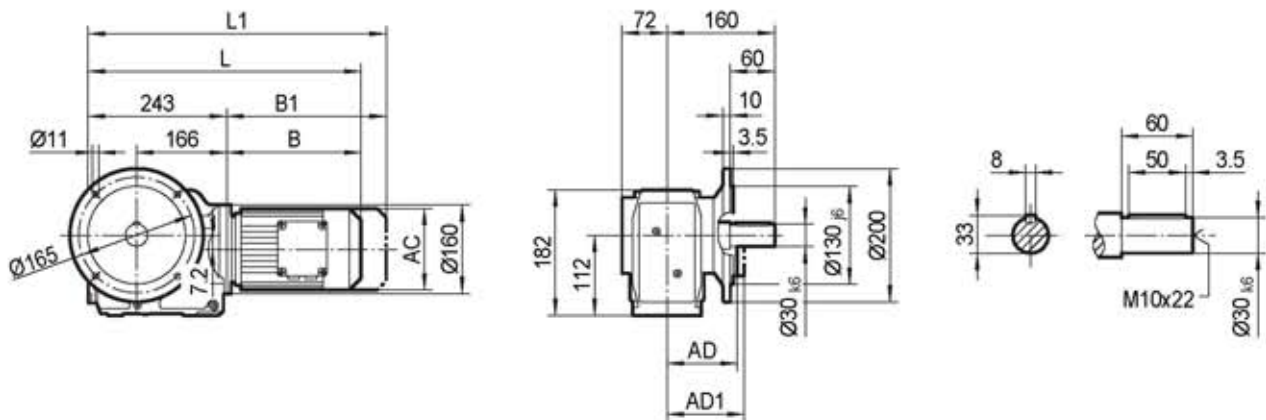

**TKAF48..**

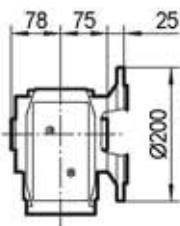

**TKHF48..**

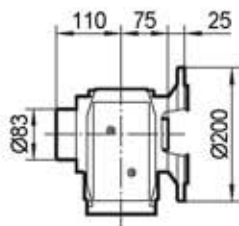

**TKVF48..**

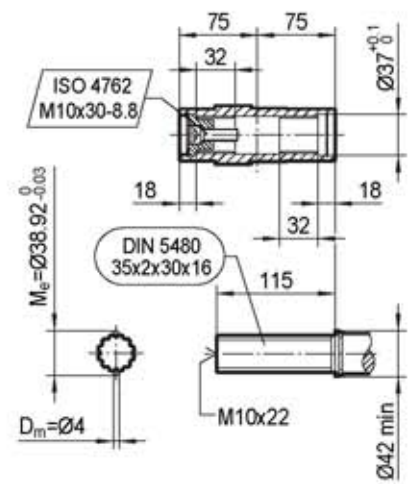
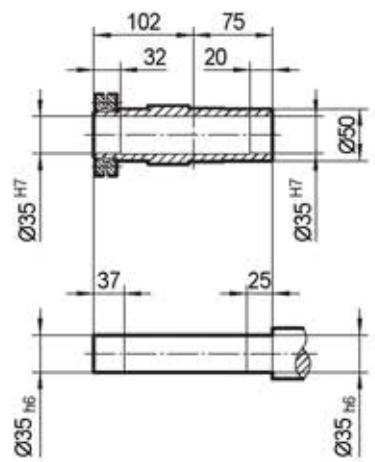
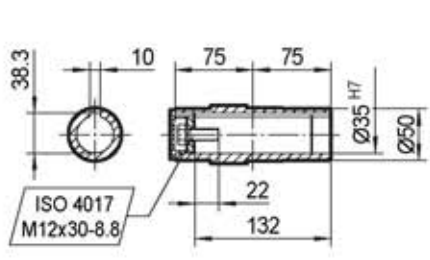
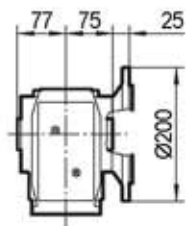

	MY63..	MY71D	MY80..	MY90..	MY100M	MY100L				
AC	132	145	145	197	197	197				
AD	105	122	122	154	166	166				
AD1	105	127	127	161	166	166				
B	185	199	249	269	319	349				
B1	240	263	313	354	404	434				
L	428	442	492	512	562	592				
L1	483	506	556	597	647	677				

**TKA48..**

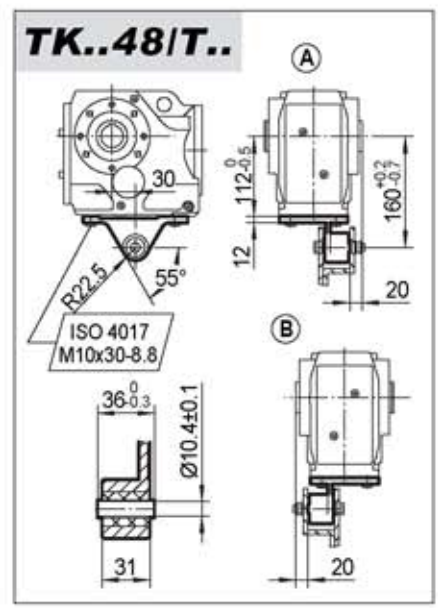
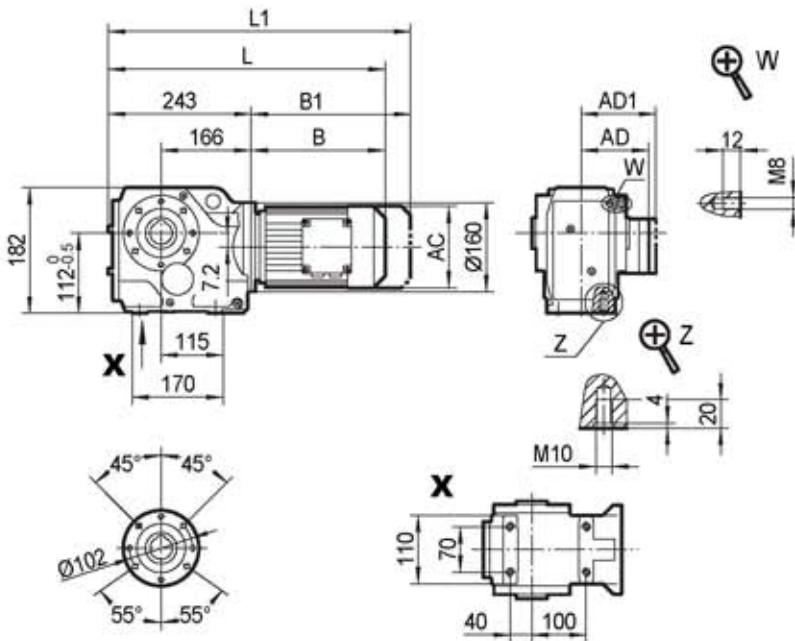

**TKA48..**

**TKH48..**

**TKV48..**

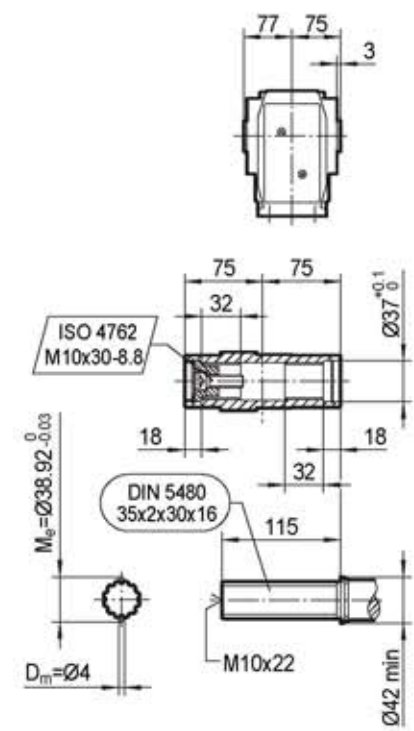
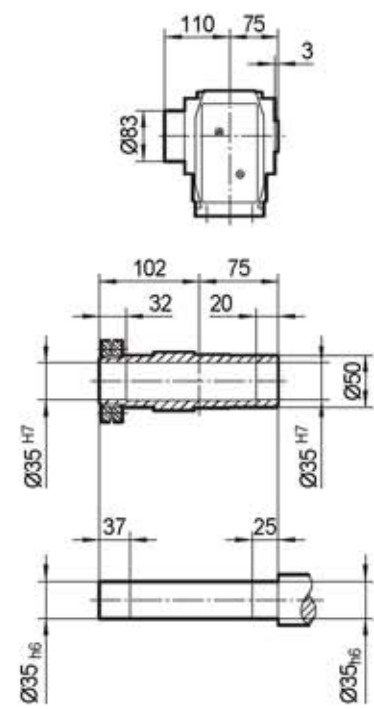
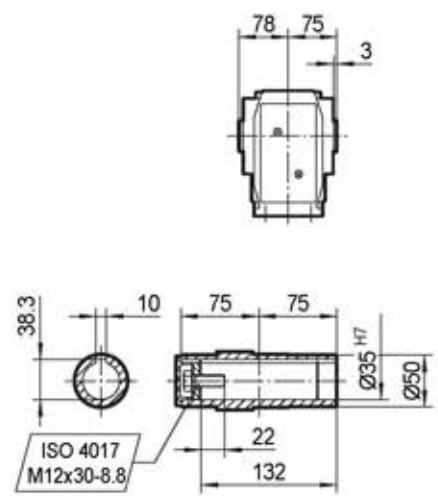

	MY63..	MY71D	MY80..	MY90..	MY100M	MY100L				
AC	132	145	145	197	197	197				
AD	105	122	122	154	166	166				
AD1	105	127	127	161	166	166				
B	185	199	249	269	319	349				
B1	240	263	313	354	404	434				
L	428	442	492	512	562	592				
L1	483	506	556	597	647	677				



**TKAZ48..**

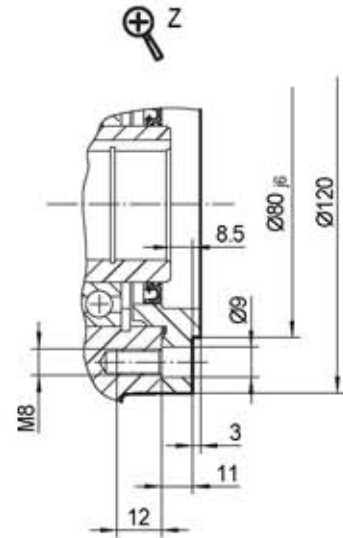
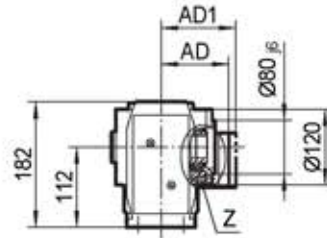
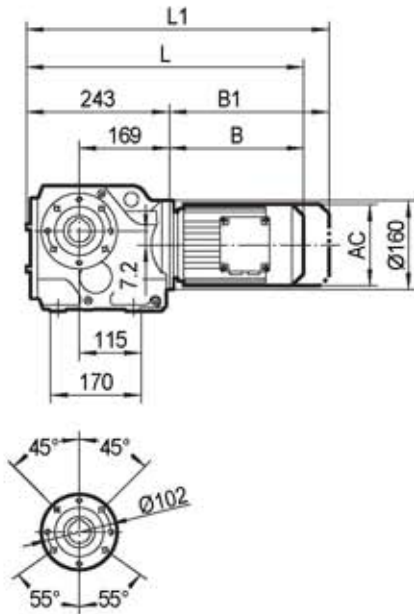

**TKAZ48..**

**TKHZ48..**

**TKVZ48..**

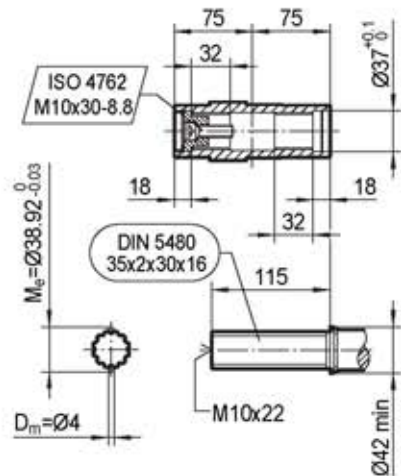
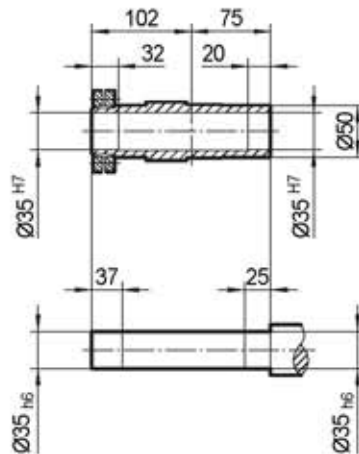
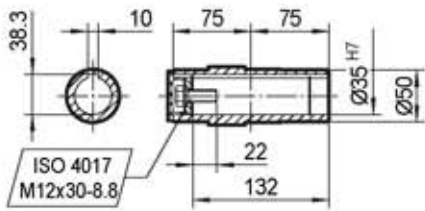
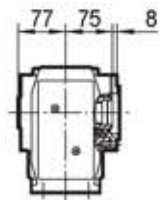
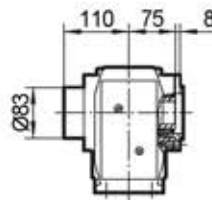
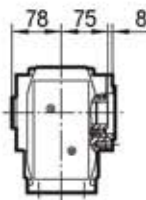

	MY63..	MY71D	MY80..	MY90..	MY100M	MY100L				
AC	132	145	145	197	197	197				
AD	105	122	122	154	166	166				
AD1	105	127	127	161	166	166				
B	185	199	249	269	319	349				
B1	240	263	313	354	404	434				
L	428	442	492	512	562	592				
L1	483	506	556	597	647	677				

**TK58..**

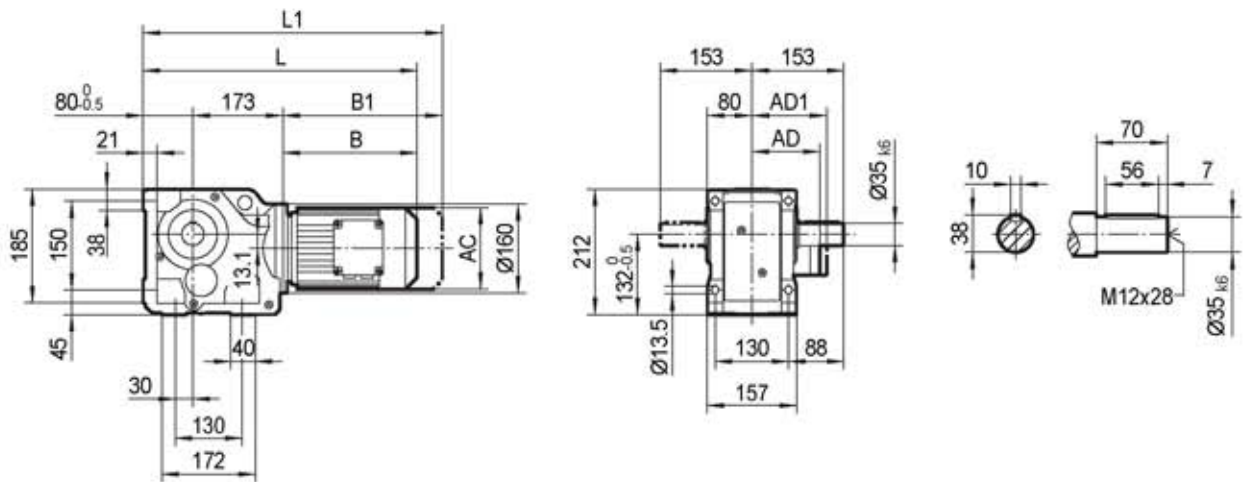

**TKA58B..**

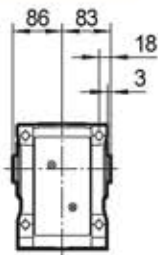

**TKH58B..**

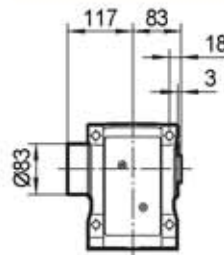

**TKV58B..**

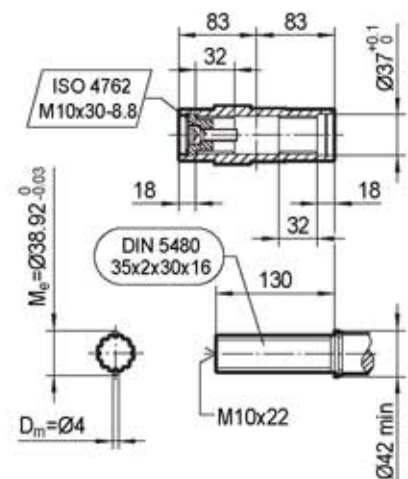
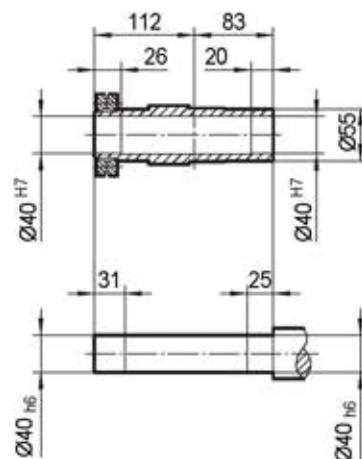
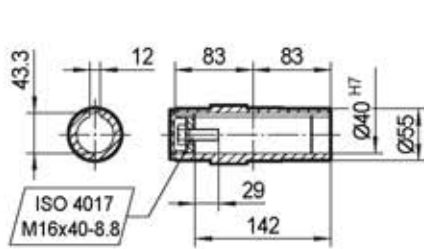
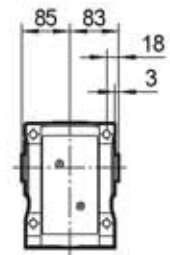

	MY63..	MY71D	MY80..	MY90..	MY100M	MY100L	MY112M			
<b>AC</b>	132	145	145	197	197	197	221			
<b>AD</b>	105	122	122	154	166	166	179			
<b>AD1</b>	105	127	127	161	166	166	182			
<b>B</b>	185	199	249	269	319	349	354			
<b>B1</b>	240	263	313	354	404	434	434			
<b>L</b>	438	452	502	522	572	602	607			
<b>L1</b>	493	516	566	607	657	687	687			

**TKF58..**

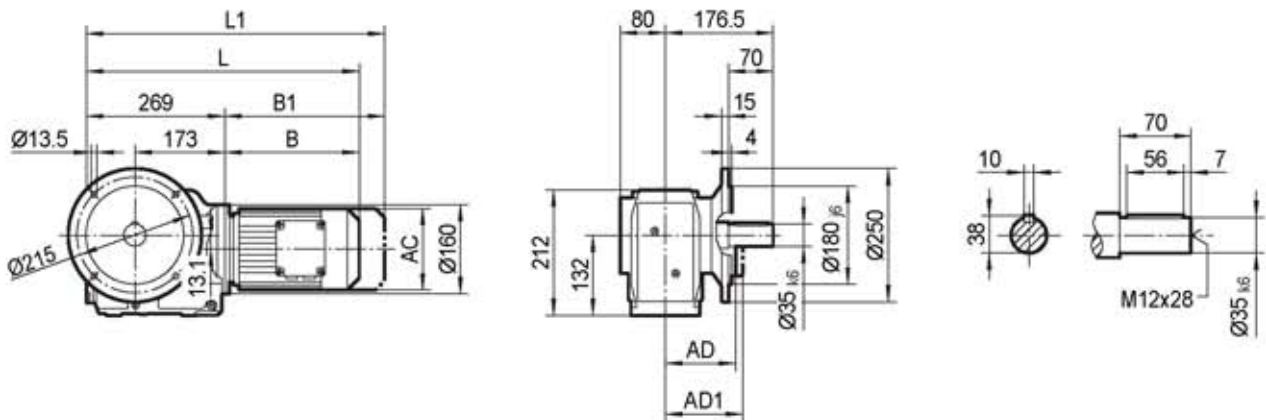

**TKAF58..**

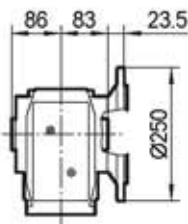

**TKHF58..**

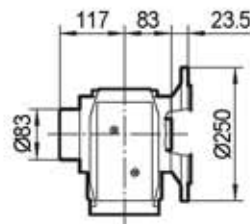

**TKVF58..**

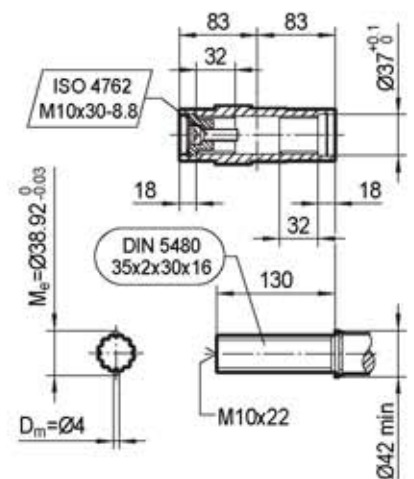
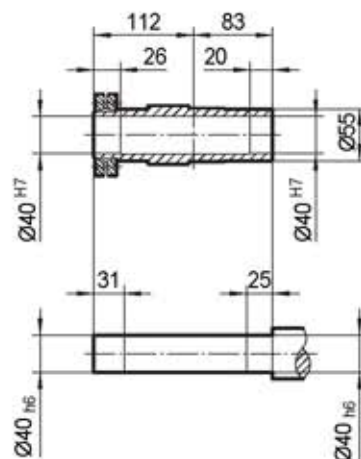
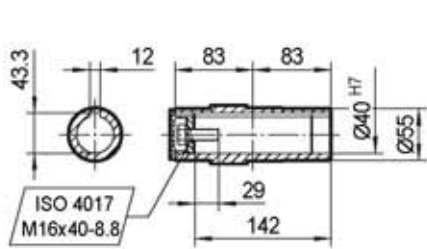
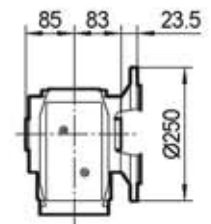

	MY63..	MY71D	MY80..	MY90..	MY100M	MY100L	MY112M				
AC	132	145	145	197	197	197	221				
AD	105	122	122	154	166	166	179				
AD1	105	127	127	161	166	166	182				
B	185	199	249	269	319	349	354				
B1	240	263	313	354	404	434	434				
L	454	468	518	538	588	618	623				
L1	509	532	582	623	673	703	703				



**TKA58..**

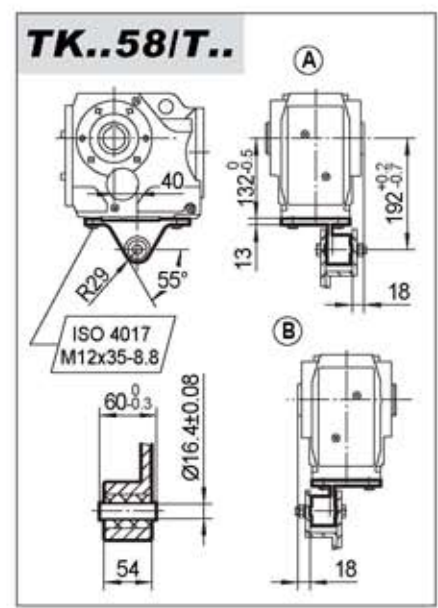
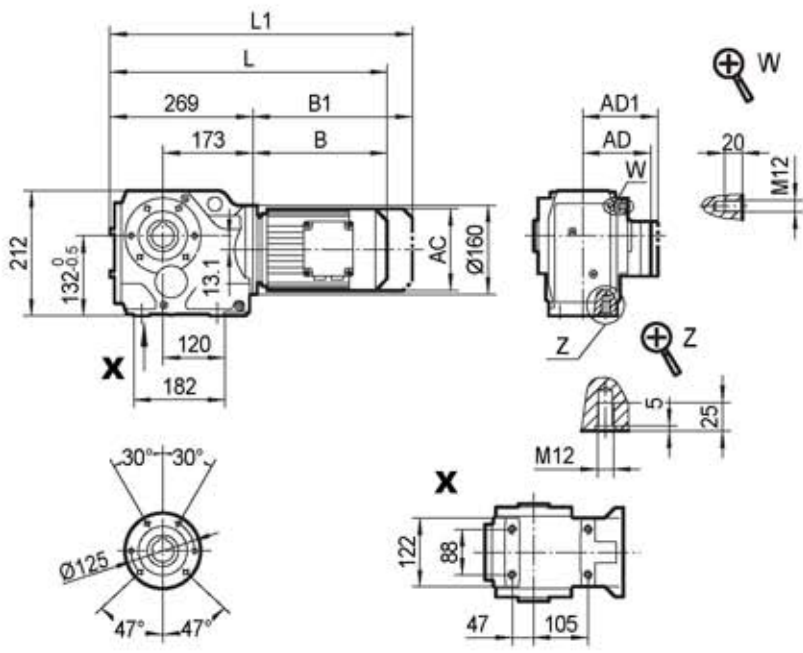

**TKA58..**

**TKH58..**

**TKV58..**

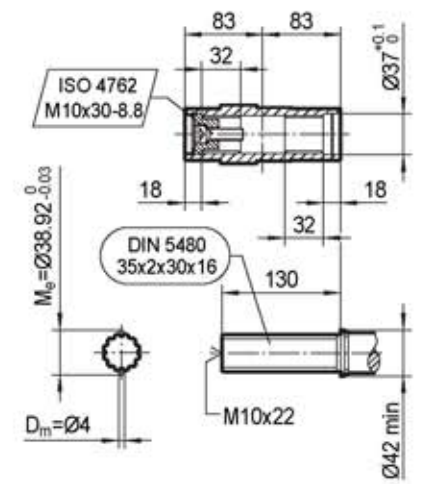
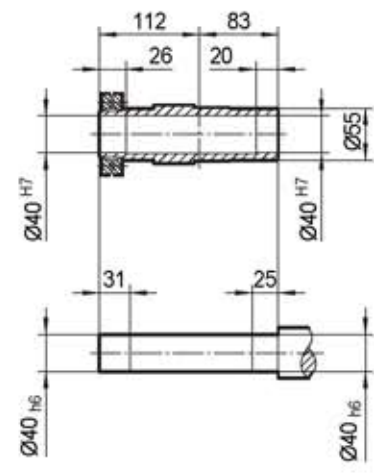
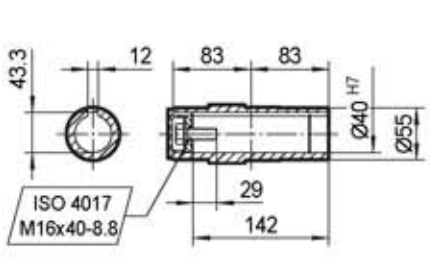
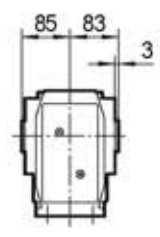
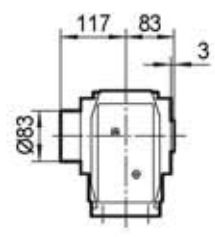
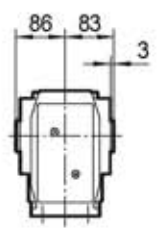

	MY63..	MY71D	MY80..	MY90..	MY100M	MY100L	MY112M			
<b>AC</b>	132	145	145	197	197	197	221			
<b>AD</b>	105	122	122	154	166	166	179			
<b>AD1</b>	105	127	127	161	166	166	182			
<b>B</b>	185	199	249	269	319	349	354			
<b>B1</b>	240	263	313	354	404	434	434			
<b>L</b>	454	468	518	538	588	618	623			
<b>L1</b>	509	532	582	623	673	703	703			

**TKAZ58..**

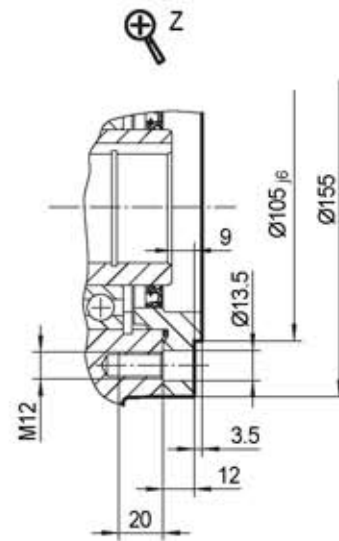
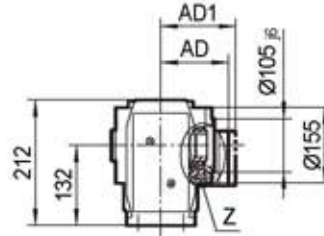
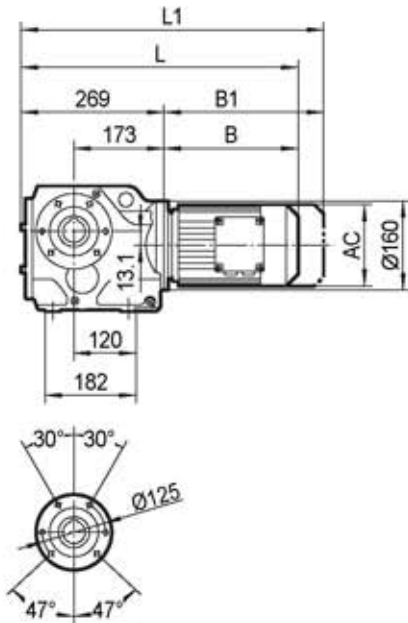

**TKAZ58..**

**TKHZ58..**

**TKVZ58..**

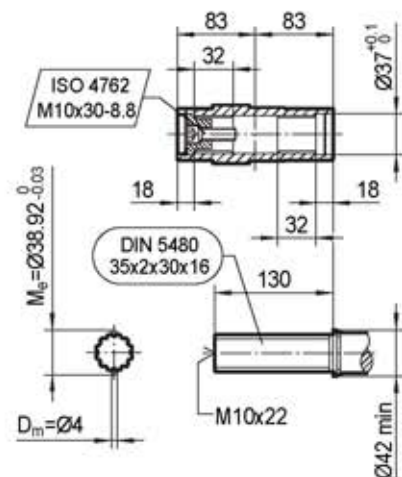
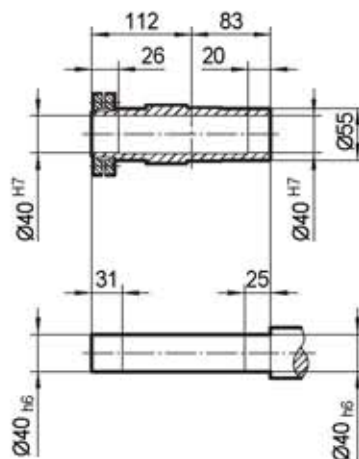
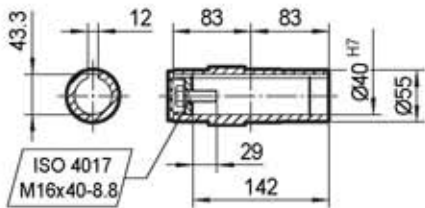
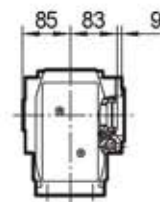
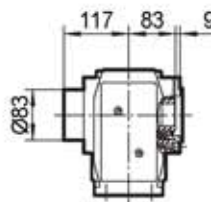
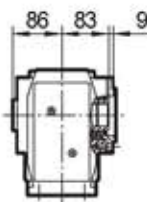

	MY63..	MY71D	MY80..	MY90..	MY100M	MY100L	MY112M			
AC	132	145	145	197	197	197	221			
AD	105	122	122	154	166	166	179			
AD1	105	127	127	161	166	166	182			
B	185	199	249	269	319	349	354			
B1	240	263	313	354	404	434	434			
L	454	468	518	538	588	618	623			
L1	509	532	582	623	673	703	703			

**TK68..**

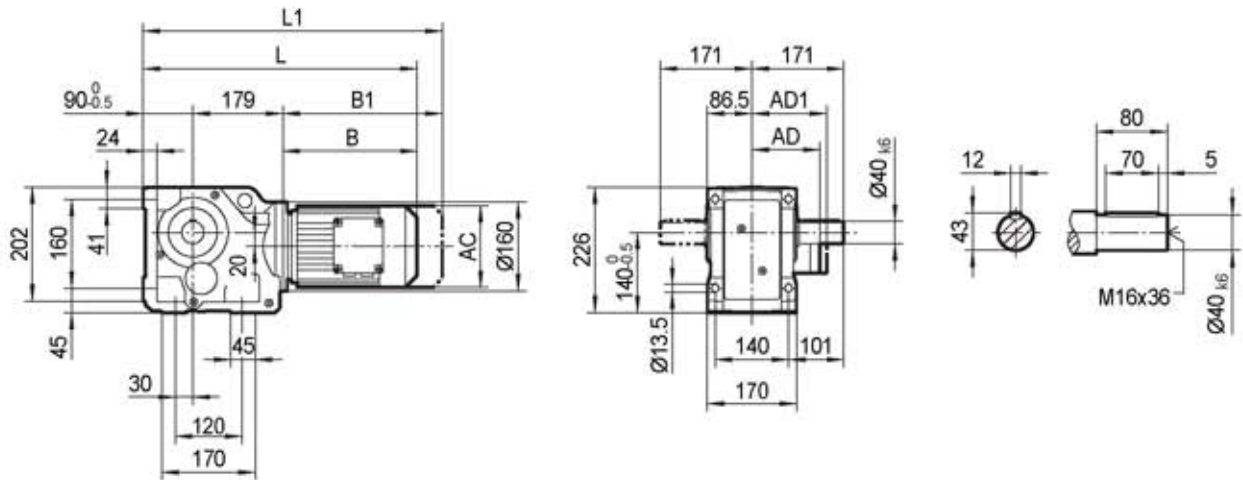

**TKA68B..**

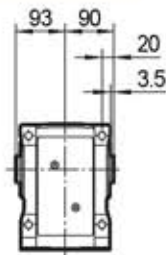

**TKH68B..**

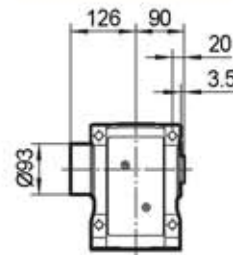

**TKV68B..**

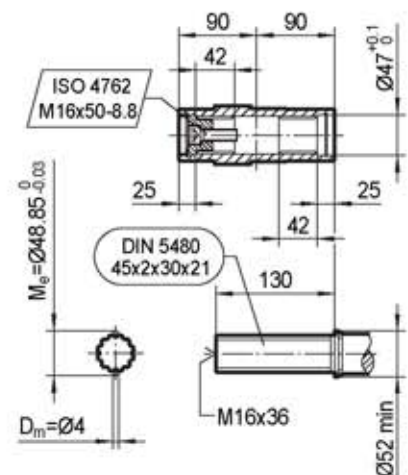
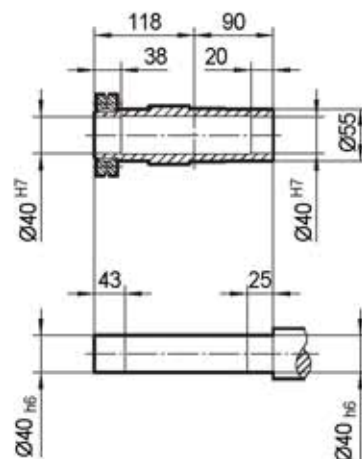
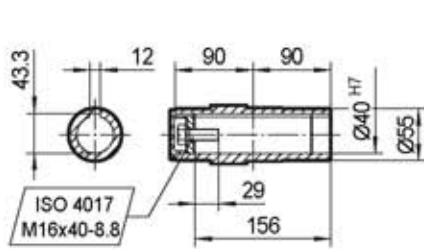
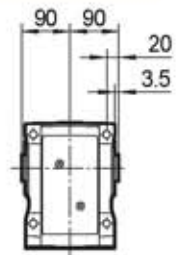

	MY63..	MY71D	MY80..	MY90..	MY100M	MY100L	MY112M	MY132S		
<b>AC</b>	132	145	145	197	197	197	221	221		
<b>AD</b>	105	122	122	154	166	166	179	179		
<b>AD1</b>	105	127	127	161	166	166	182	182		
<b>B</b>	185	199	249	269	319	349	354	402		
<b>B1</b>	240	263	313	354	404	434	434	482		
<b>L</b>	454	468	518	538	588	618	623	671		
<b>L1</b>	509	532	582	623	673	703	703	751		



**TKF68..**

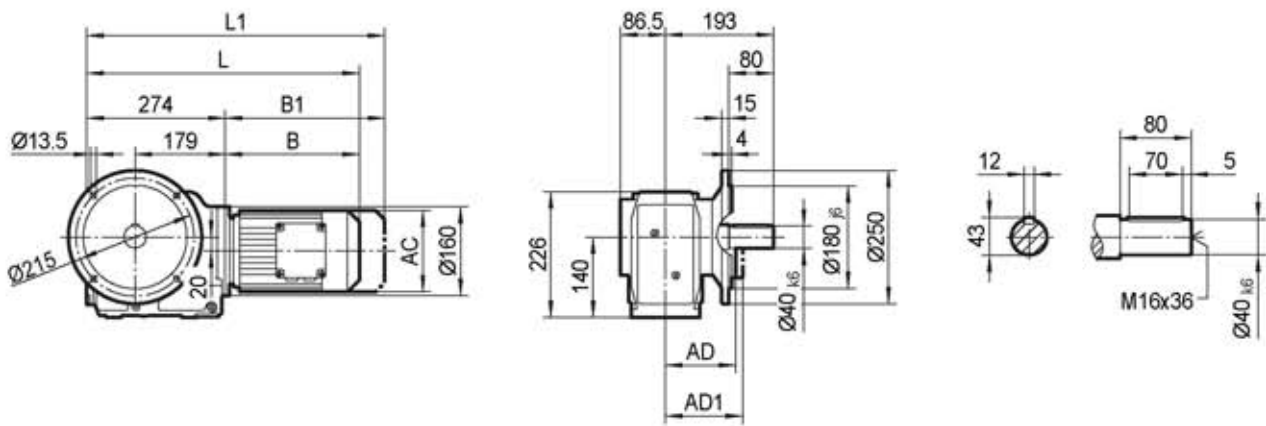

**TKAF68..**

**TKHF68..**

**TKVF68..**

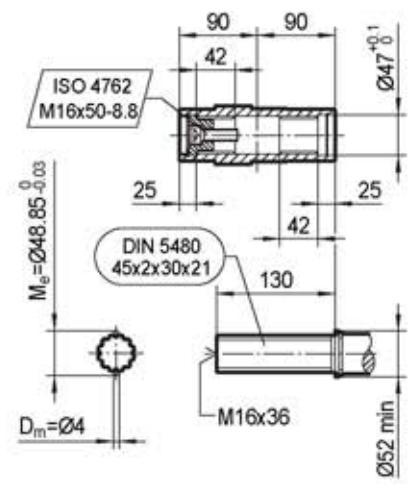
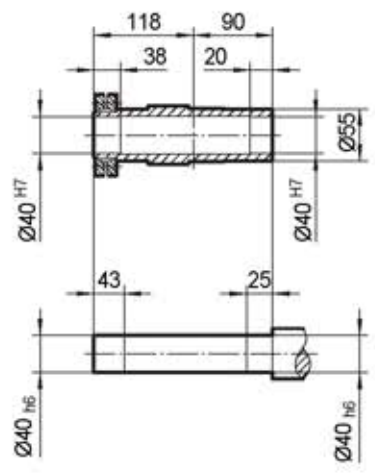
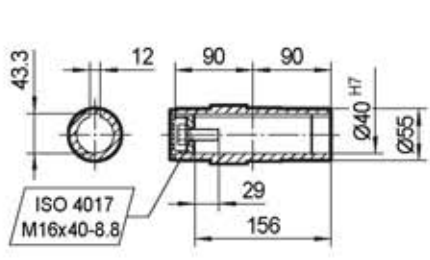
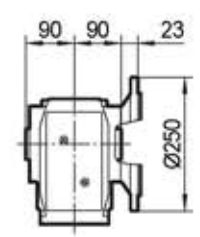
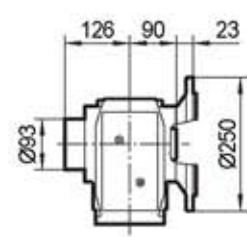
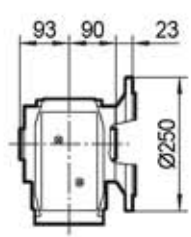

	MY63..	MY71D	MY80..	MY90..	MY100M	MY100L	MY112M	MY132S		
AC	132	145	145	197	197	197	221	221		
AD	105	122	122	154	166	166	179	179		
AD1	105	127	127	161	166	166	182	182		
B	185	199	249	269	319	349	354	402		
B1	240	263	313	354	404	434	434	482		
L	459	473	523	543	593	623	628	676		
L1	514	537	587	628	678	708	708	756		

**TKA68..**

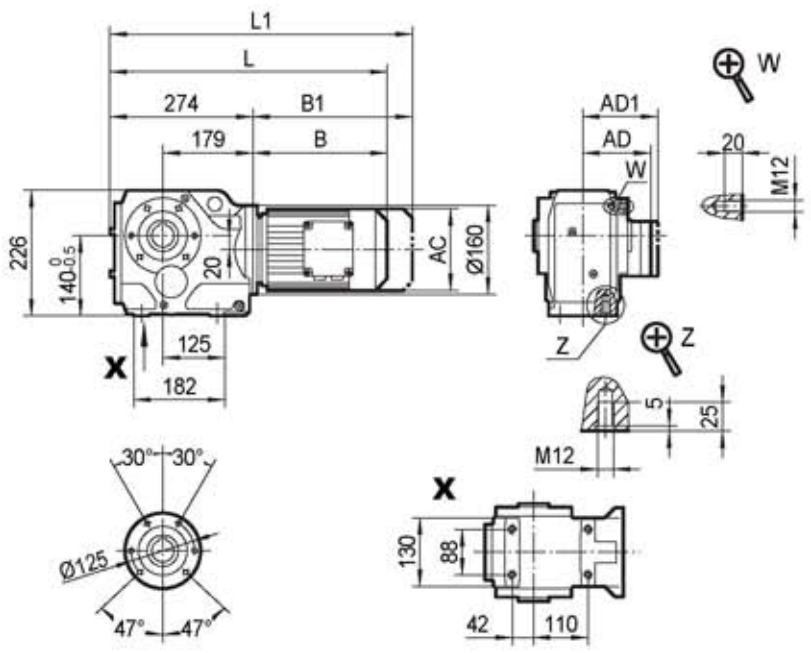

**TK..68/T..**

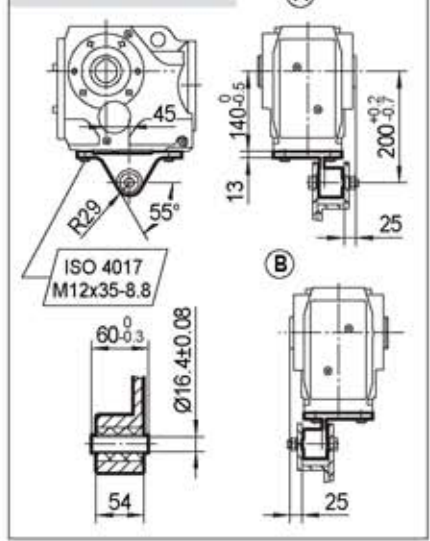

**TKA68..**

**TKH68..**

**TKV68..**

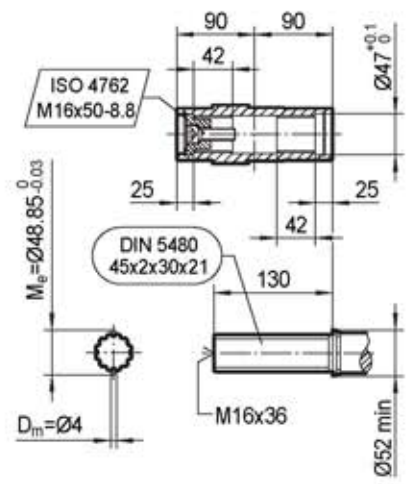
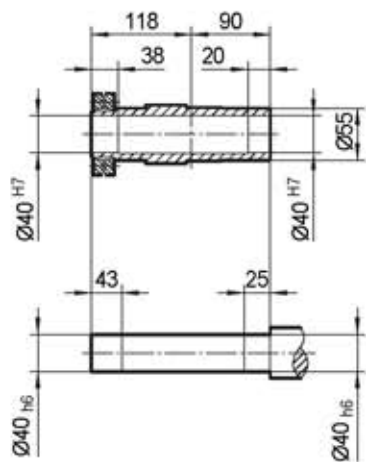
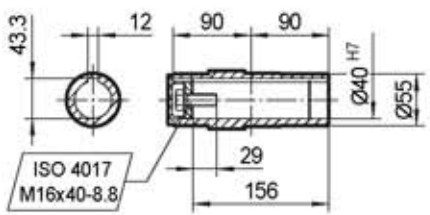
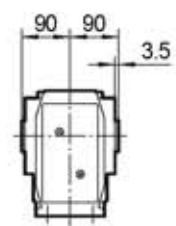
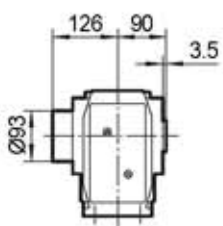
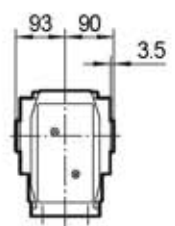

	MY63..	MY71D	MY80..	MY90..	MY100M	MY100L	MY112M	MY132S		
<b>AC</b>	132	145	145	197	197	197	221	221		
<b>AD</b>	105	122	122	154	166	166	179	179		
<b>AD1</b>	105	127	127	161	166	166	182	182		
<b>B</b>	185	199	249	269	319	349	354	402		
<b>B1</b>	240	263	313	354	404	434	434	482		
<b>L</b>	459	473	523	543	593	623	628	676		
<b>L1</b>	514	537	587	628	678	708	708	756		

**TKAZ68..**

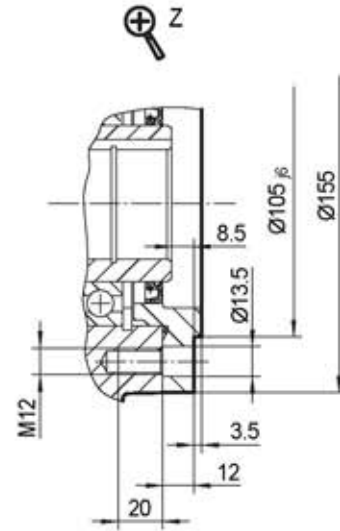
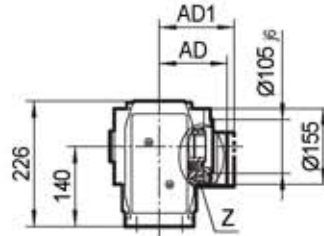
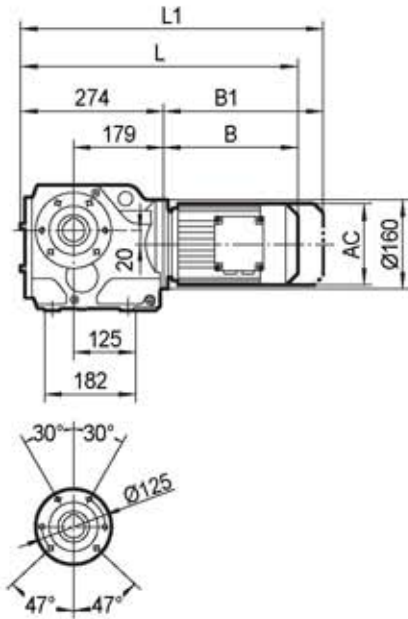

**TKAZ68..**

**TKHZ68..**

**TKVZ68..**

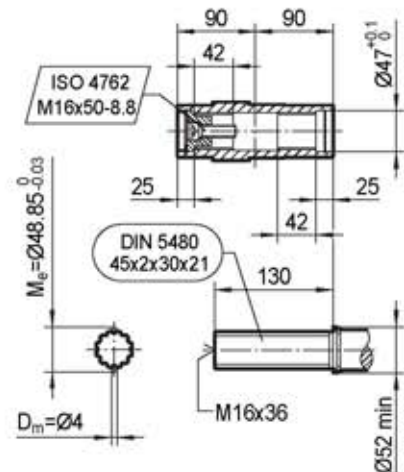
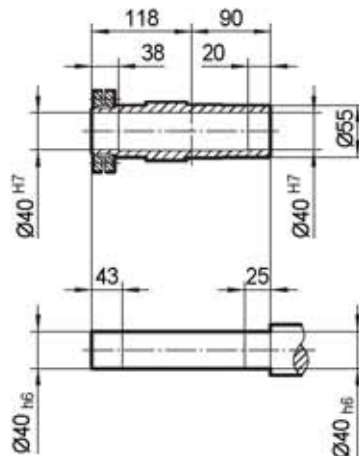
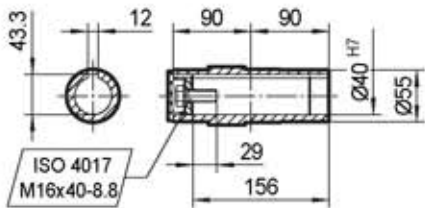
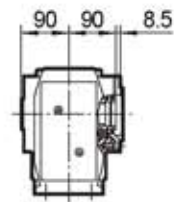
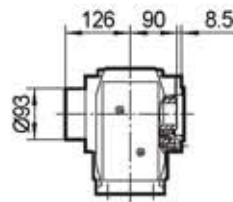
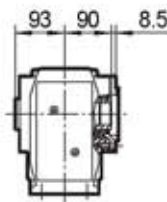

	MY63..	MY71D	MY80..	MY90..	MY100M	MY100L	MY112M	MY132S		
AC	132	145	145	197	197	197	221	221		
AD	105	122	122	154	166	166	179	179		
AD1	105	127	127	161	166	166	182	182		
B	185	199	249	269	319	349	354	402		
B1	240	263	313	354	404	434	434	482		
L	459	473	523	543	593	623	628	676		
L1	514	537	587	628	678	708	708	756		



**TK78..**

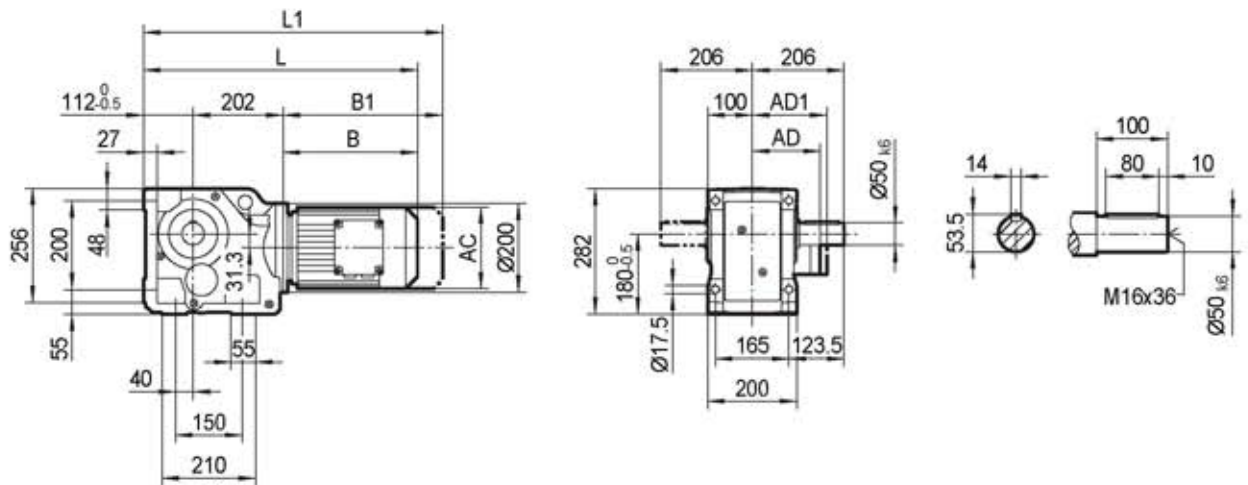

**TKA78B..**

**TKH78B..**

**TKV78B..**

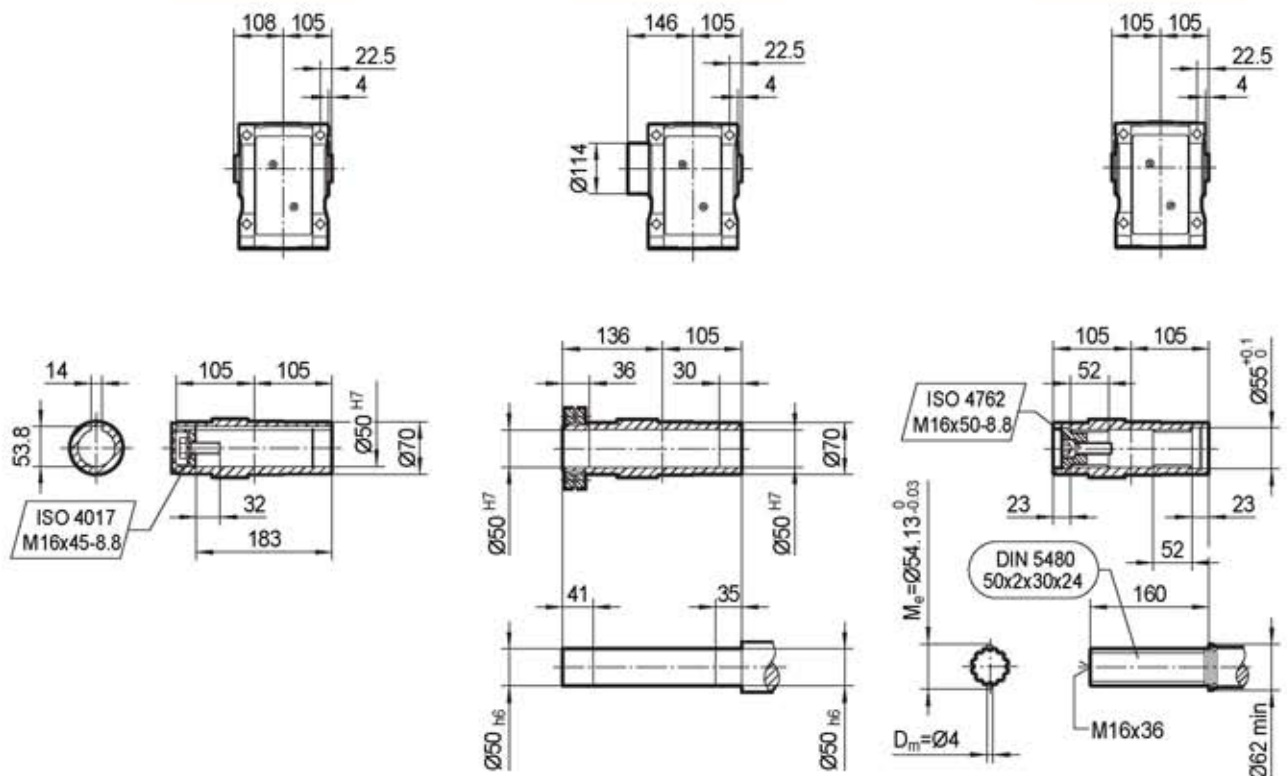

	MY71D	MY80..	MY90..	MY100M	MY100L	MY112M	MY132S	MY132M	MY132ML	MY160M
<b>AC</b>	145	145	197	197	197	221	221	275	275	275
<b>AD</b>	122	122	154	166	166	179	179	230	230	230
<b>AD1</b>	127	127	161	166	166	182	182	230	230	230
<b>B</b>	193	243	261	311	341	345	390	412	472	472
<b>B1</b>	257	307	346	396	426	425	470	524	584	584
<b>L</b>	507	557	575	625	655	659	704	726	786	786
<b>L1</b>	571	621	660	710	740	739	784	838	898	898

**TKF78..**

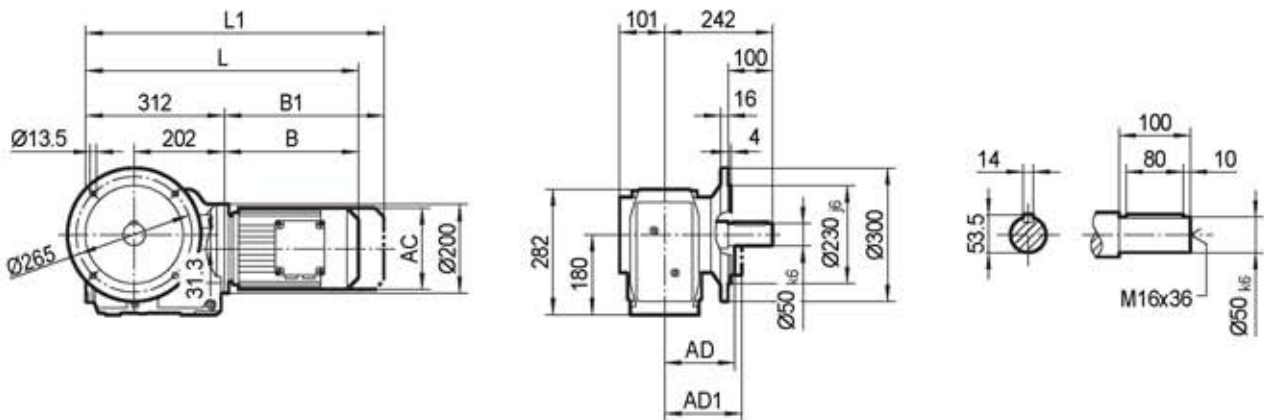

**TKAF78..**

**TKHF78..**

**TKVF78..**

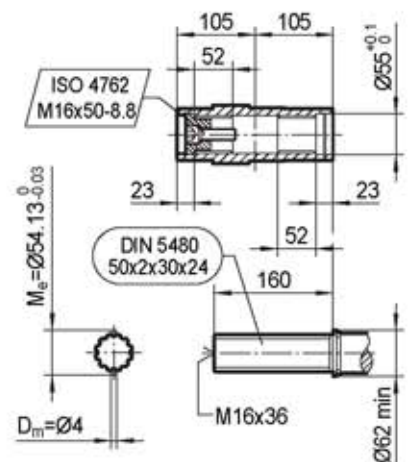
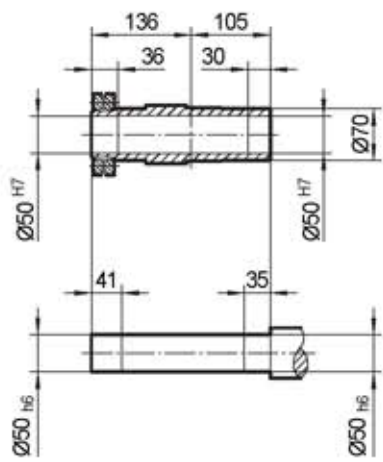
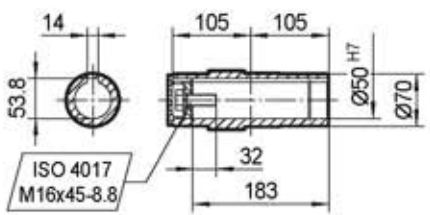
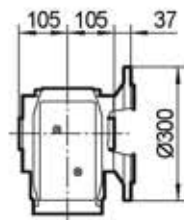
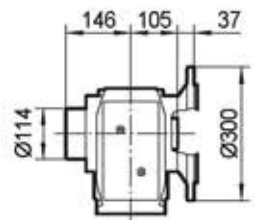
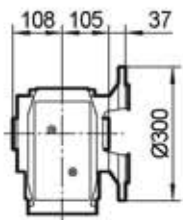

	MY71D	MY80..	MY90..	MY100M	MY100L	MY112M	MY132S	MY132M	MY132ML	MY160M
AC	145	145	197	197	197	221	221	275	275	275
AD	122	122	154	166	166	179	179	230	230	230
AD1	127	127	161	166	166	182	182	230	230	230
B	193	243	261	311	341	345	390	412	472	472
B1	257	307	346	396	426	425	470	524	584	584
L	505	555	573	623	653	657	702	724	784	784
L1	569	619	658	708	738	737	782	836	896	896

**TKA78..**

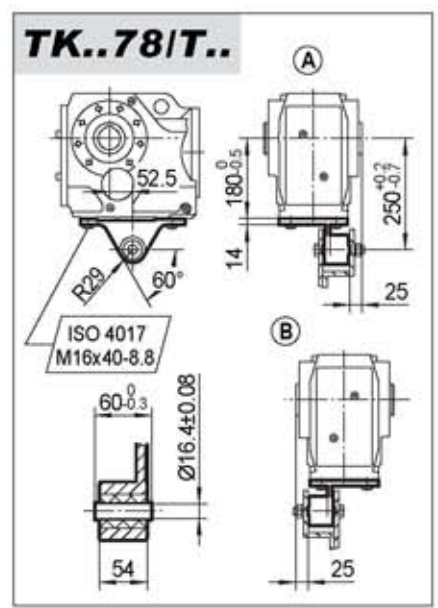
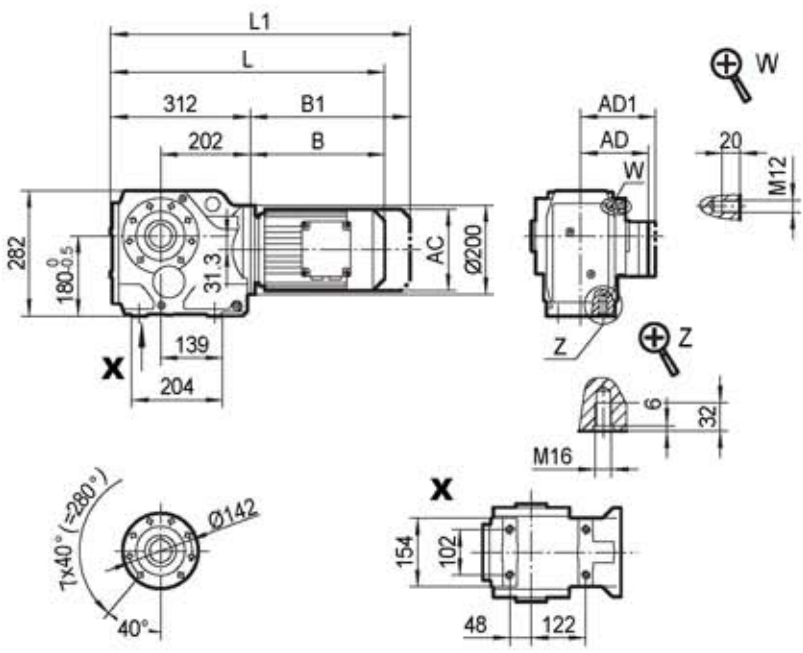

**TKA78..**

**TKH78..**

**TKV78..**

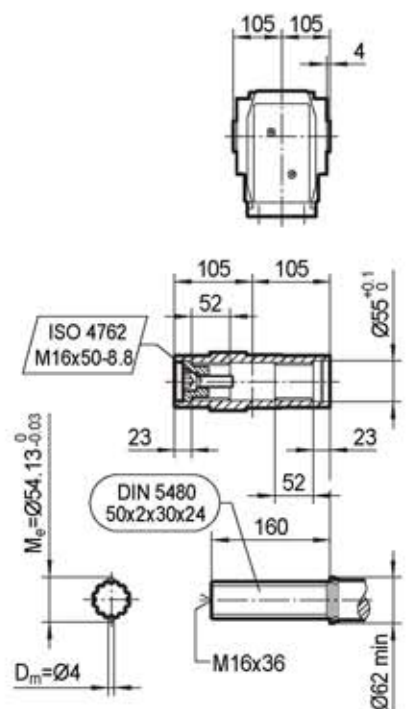
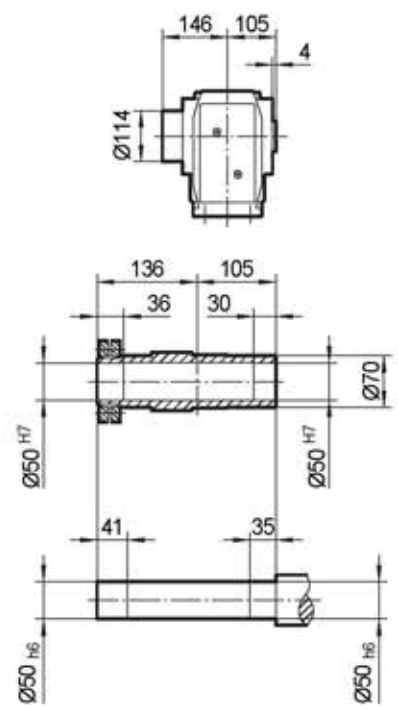
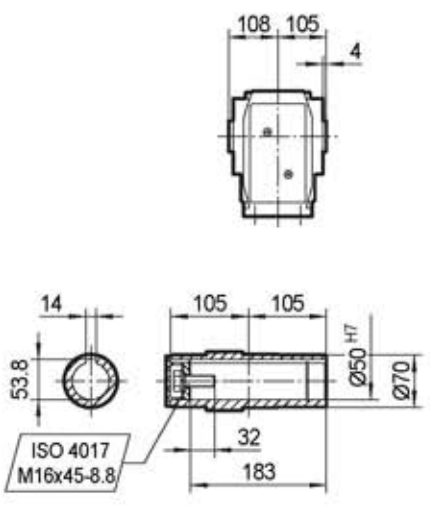

	MY71D	MY80..	MY90..	MY100M	MY100L	MY112M	MY132S	MY132M	MY132ML	MY160M
<b>AC</b>	145	145	197	197	197	221	221	275	275	275
<b>AD</b>	122	122	154	166	166	179	179	230	230	230
<b>AD1</b>	127	127	161	166	166	182	182	230	230	230
<b>B</b>	193	243	261	311	341	345	390	412	472	472
<b>B1</b>	257	307	346	396	426	425	470	524	584	584
<b>L</b>	505	555	573	623	653	657	702	724	784	784
<b>L1</b>	569	619	658	708	738	737	782	836	896	896



**TKAZ78..**

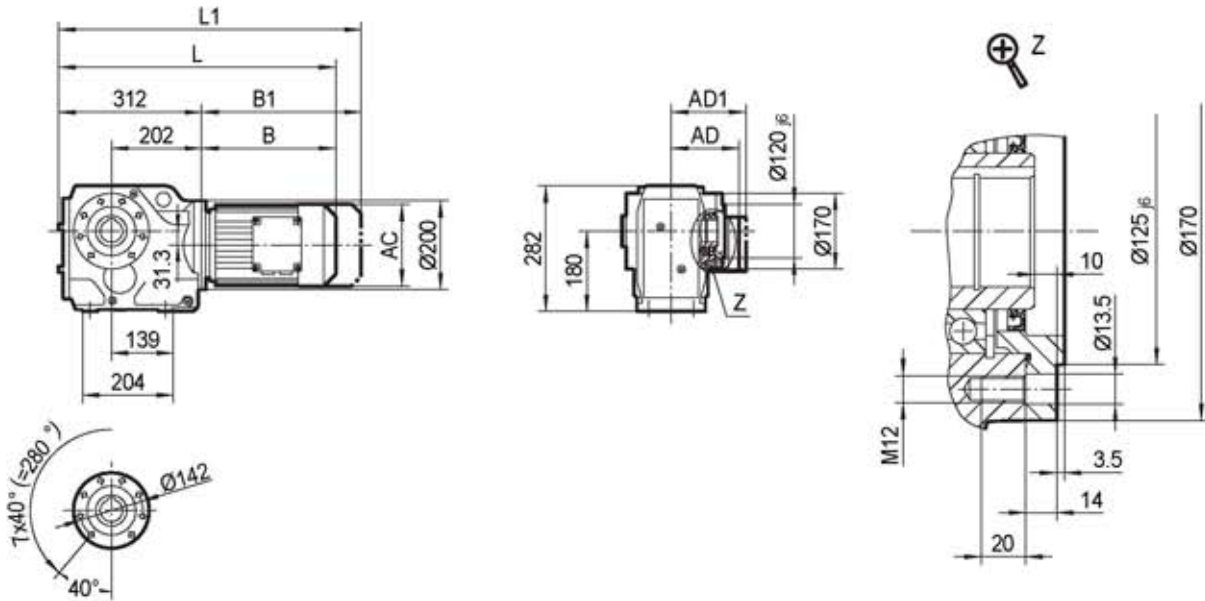

**TKAZ78..**

**TKHZ78..**

**TKVZ78..**

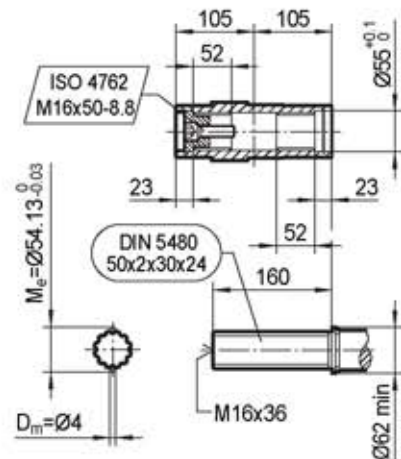
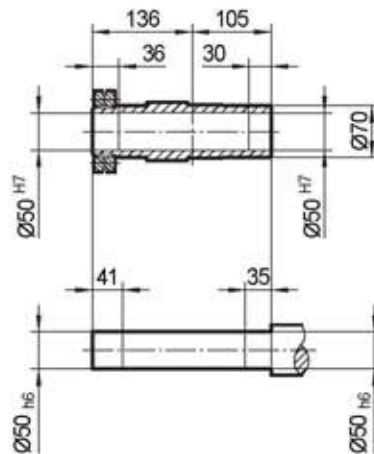
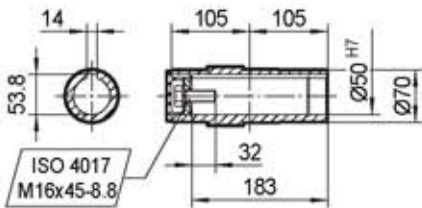
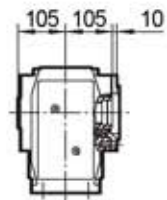
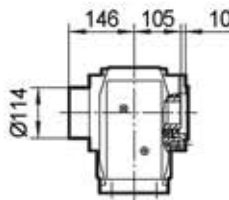
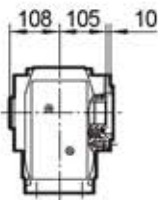

	MY71D	MY80..	MY90..	MY100M	MY100L	MY112M	MY132S	MY132M	MY132ML	MY160M
AC	145	145	197	197	197	221	221	275	275	275
AD	122	122	154	166	166	179	179	230	230	230
AD1	127	127	161	166	166	182	182	230	230	230
B	193	243	261	311	341	345	390	412	472	472
B1	257	307	346	396	426	425	470	524	584	584
L	505	555	573	623	653	657	702	724	784	784
L1	569	619	658	708	738	737	782	836	896	896

**TK88..**

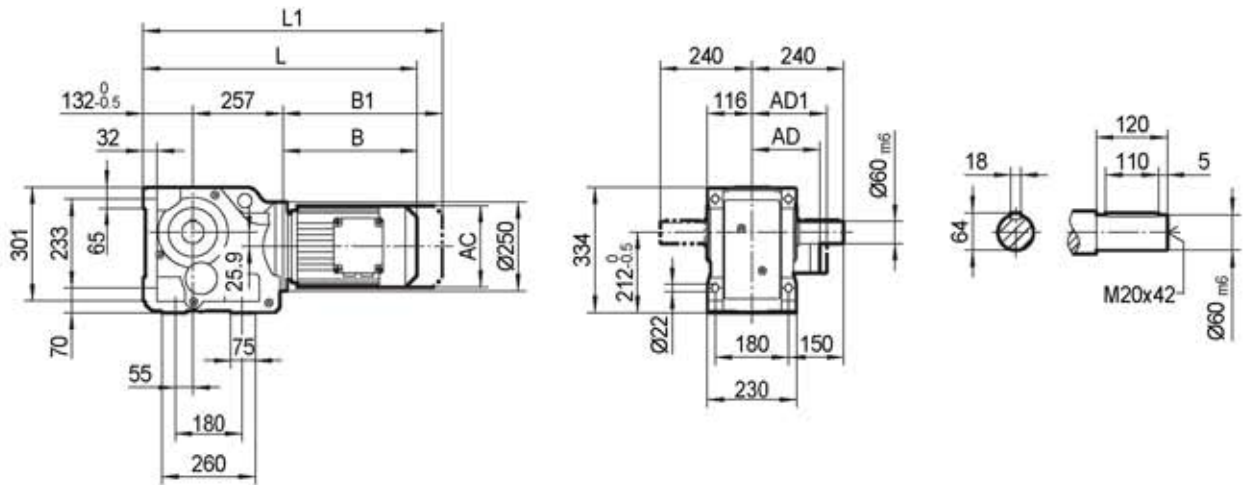

**TKA88B..**

**TKH88B..**

**TKV88B..**

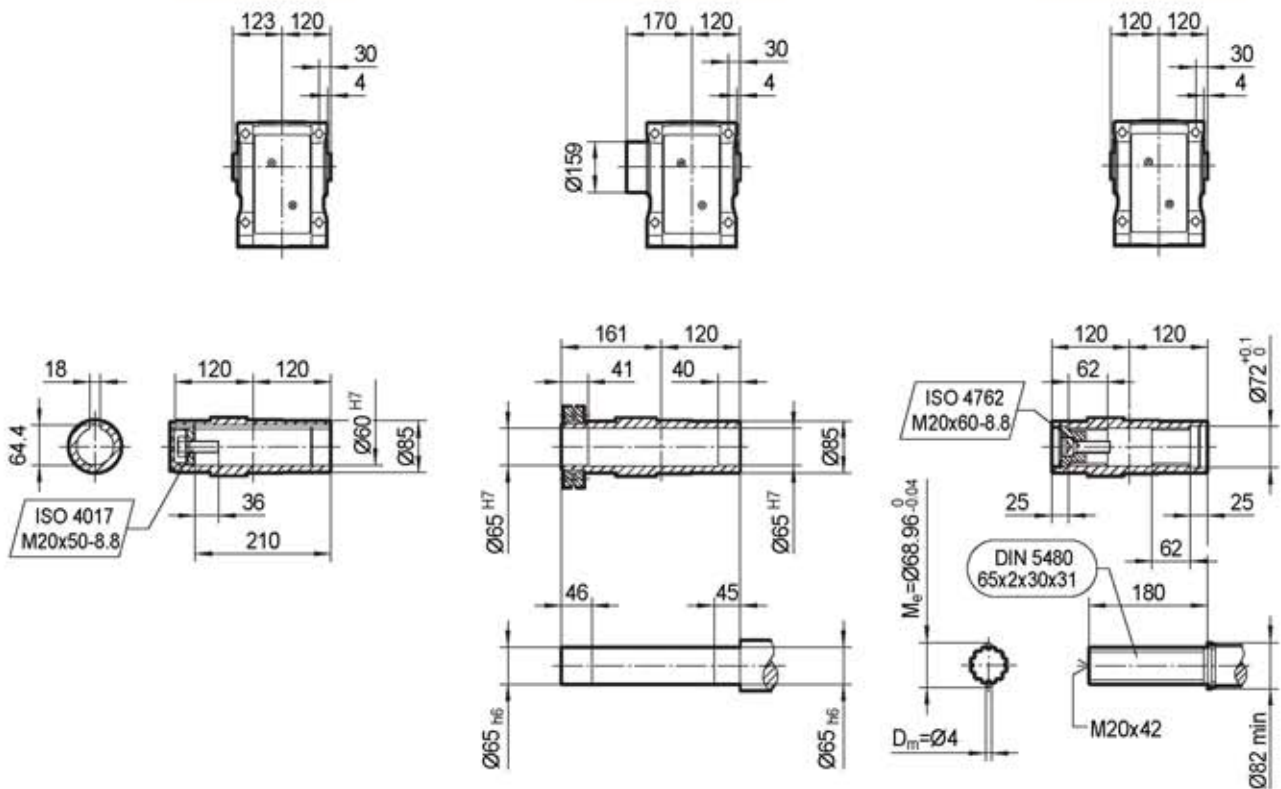

	MY80..	MY90..	MY100M	MY100L	MY112M	MY132S	MY132M	MY132ML	MY160M	MY160L	MY180..
<b>AC</b>	145	197	197	197	221	221	275	275	275	331	331
<b>AD</b>	122	154	166	166	179	179	230	230	230	258	258
<b>AD1</b>	127	161	166	166	182	182	230	230	230	258	258
<b>B</b>	238	257	307	337	340	385	407	467	467	514	586
<b>B1</b>	302	342	392	422	420	465	519	579	579	670	742
<b>L</b>	627	646	696	726	729	774	796	856	856	903	975
<b>L1</b>	691	731	781	811	809	854	908	968	968	1059	1131

**TKF88..**

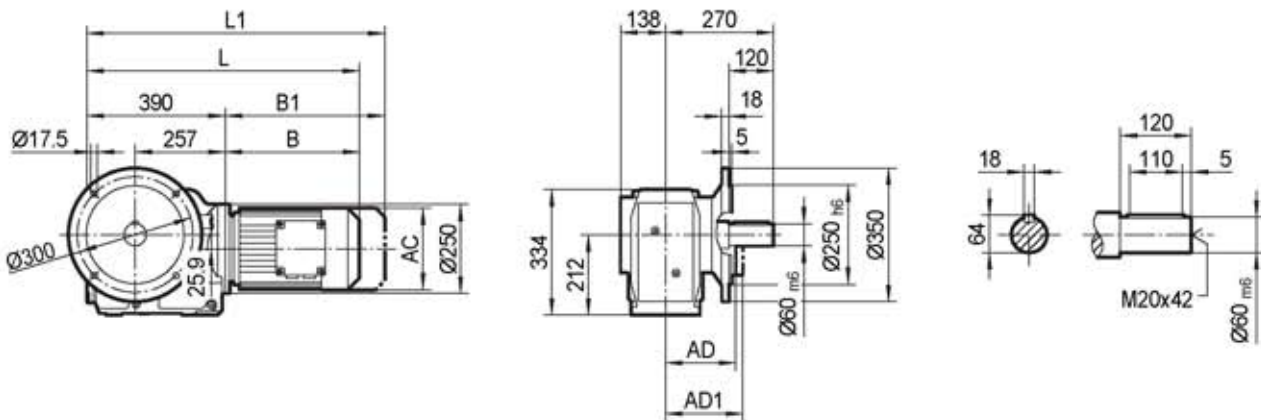

**TKAF88..**

**TKHF88..**

**TKVF88..**

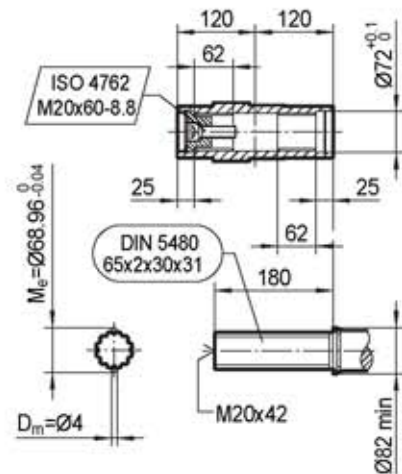
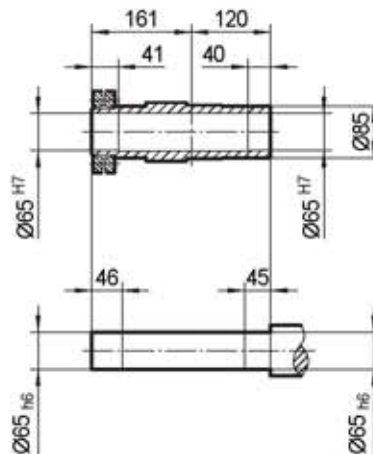
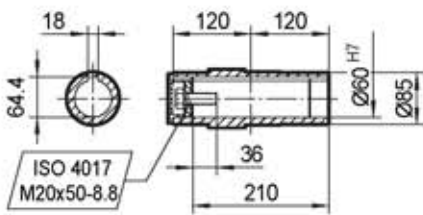
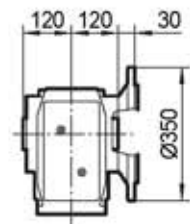
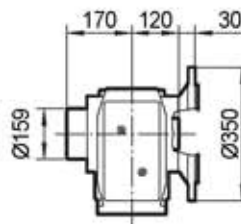
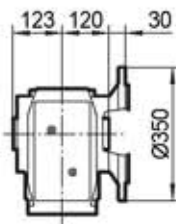

	MY80..	MY90..	MY100M	MY100L	MY112M	MY132S	MY132M	MY132ML	MY160M	MY160L	MY180..
AC	145	197	197	197	221	221	275	275	275	331	331
AD	122	154	166	166	179	179	230	230	230	258	258
AD1	127	161	166	166	182	182	230	230	230	258	258
B	238	257	307	337	340	385	407	467	467	514	586
B1	302	342	392	422	420	465	519	579	579	670	742
L	628	647	697	727	730	775	797	857	857	904	976
L1	692	732	782	812	810	855	909	969	969	1060	1132



**TKA88..**

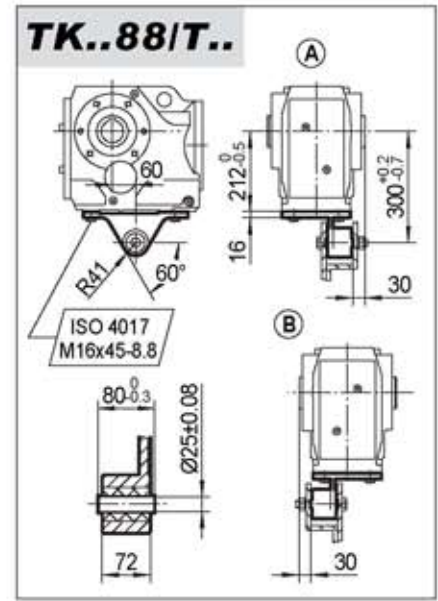
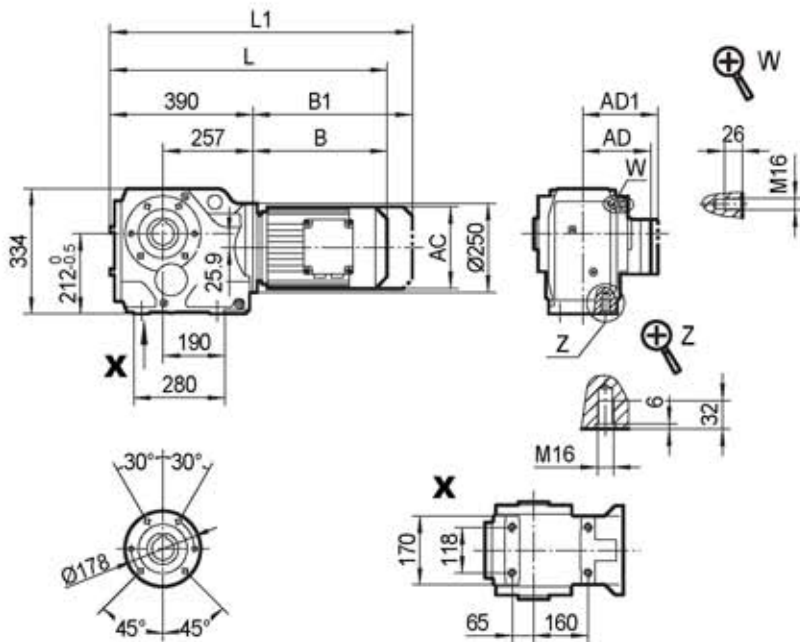

**TKA88..**

**TKH88..**

**TKV88..**

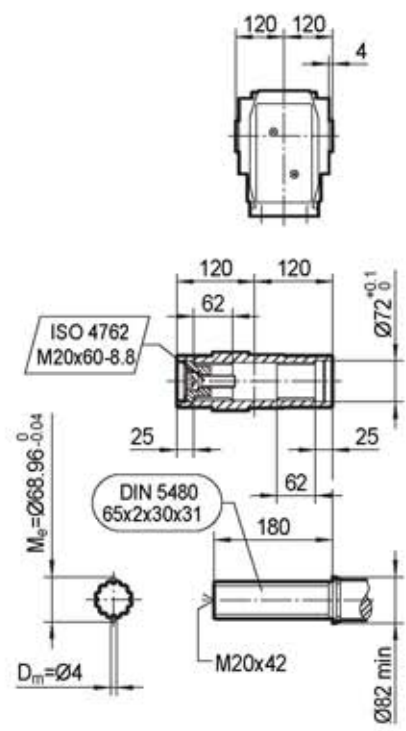
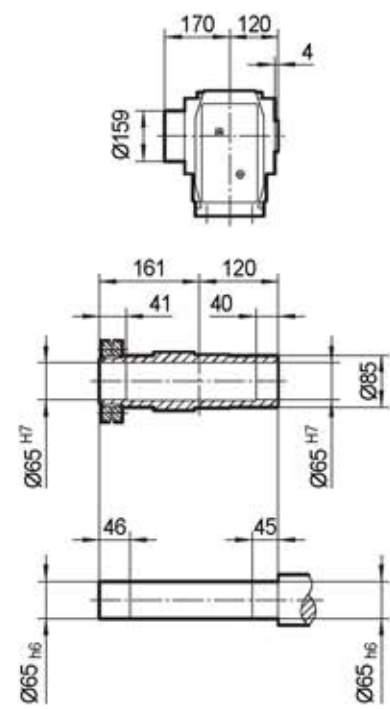
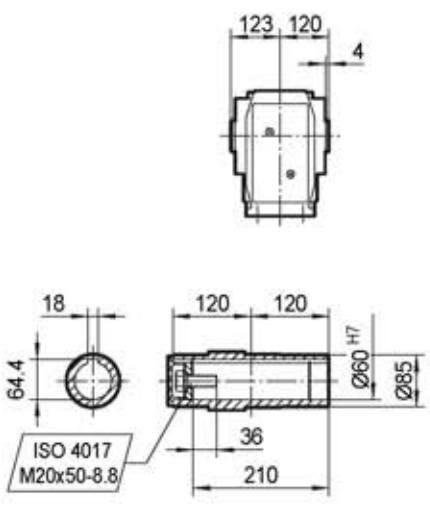

	MY80..	MY90..	MY100M	MY100L	MY112M	MY132S	MY132M	MY132ML	MY160M	MY160L	MY180..
<b>AC</b>	145	197	197	197	221	221	275	275	275	331	331
<b>AD</b>	122	154	166	166	179	179	230	230	230	258	258
<b>AD1</b>	127	161	166	166	182	182	230	230	230	258	258
<b>B</b>	238	257	307	337	340	385	407	467	467	514	586
<b>B1</b>	302	342	392	422	420	465	519	579	579	670	742
<b>L</b>	628	647	697	727	730	775	797	857	857	904	976
<b>L1</b>	692	732	782	812	810	855	909	969	969	1060	1132

**TKAZ88..**

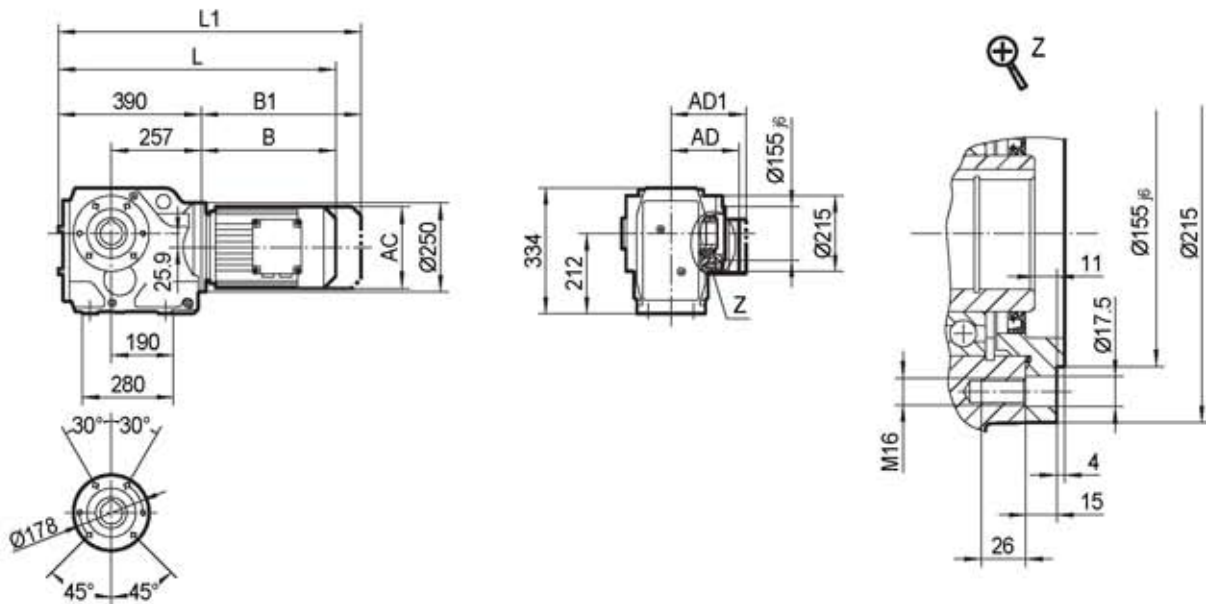

**TKAZ88..**

**TKHZ88..**

**TKVZ88..**

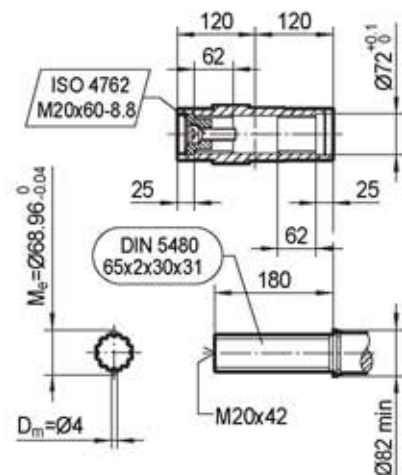
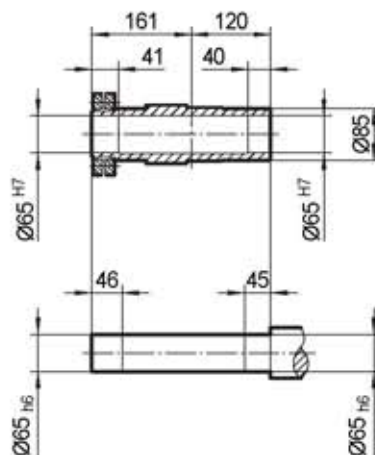
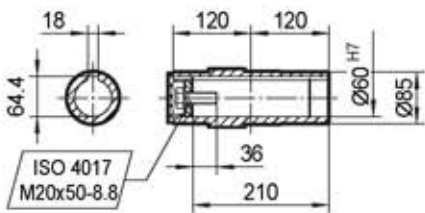
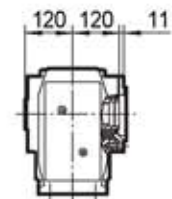
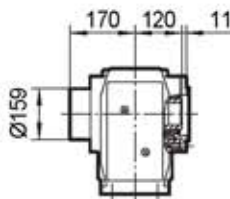
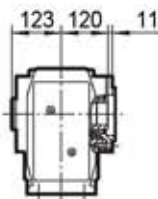

	MY80..	MY90..	MY100M	MY100L	MY112M	MY132S	MY132M	MY132ML	MY160M	MY160L	MY180..
AC	145	197	197	197	221	221	275	275	275	331	331
AD	122	154	166	166	179	179	230	230	230	258	258
AD1	127	161	166	166	182	182	230	230	230	258	258
B	238	257	307	337	340	385	407	467	467	514	586
B1	302	342	392	422	420	465	519	579	579	670	742
L	628	647	697	727	730	775	797	857	857	904	976
L1	692	732	782	812	810	855	909	969	969	1060	1132

**TK98..**

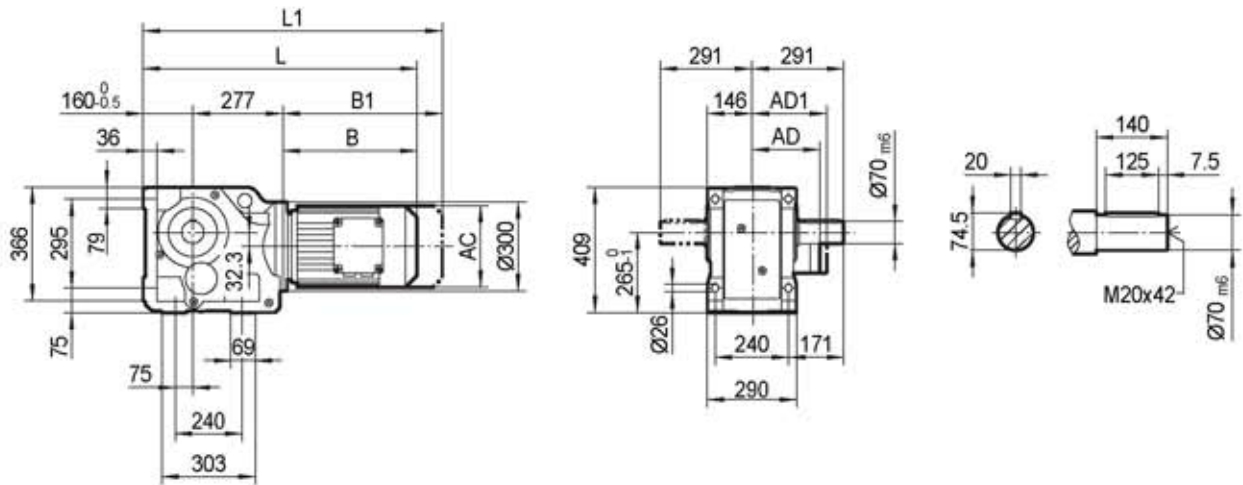

**TKA98B..**

**TKH98B..**

**TKV98B..**

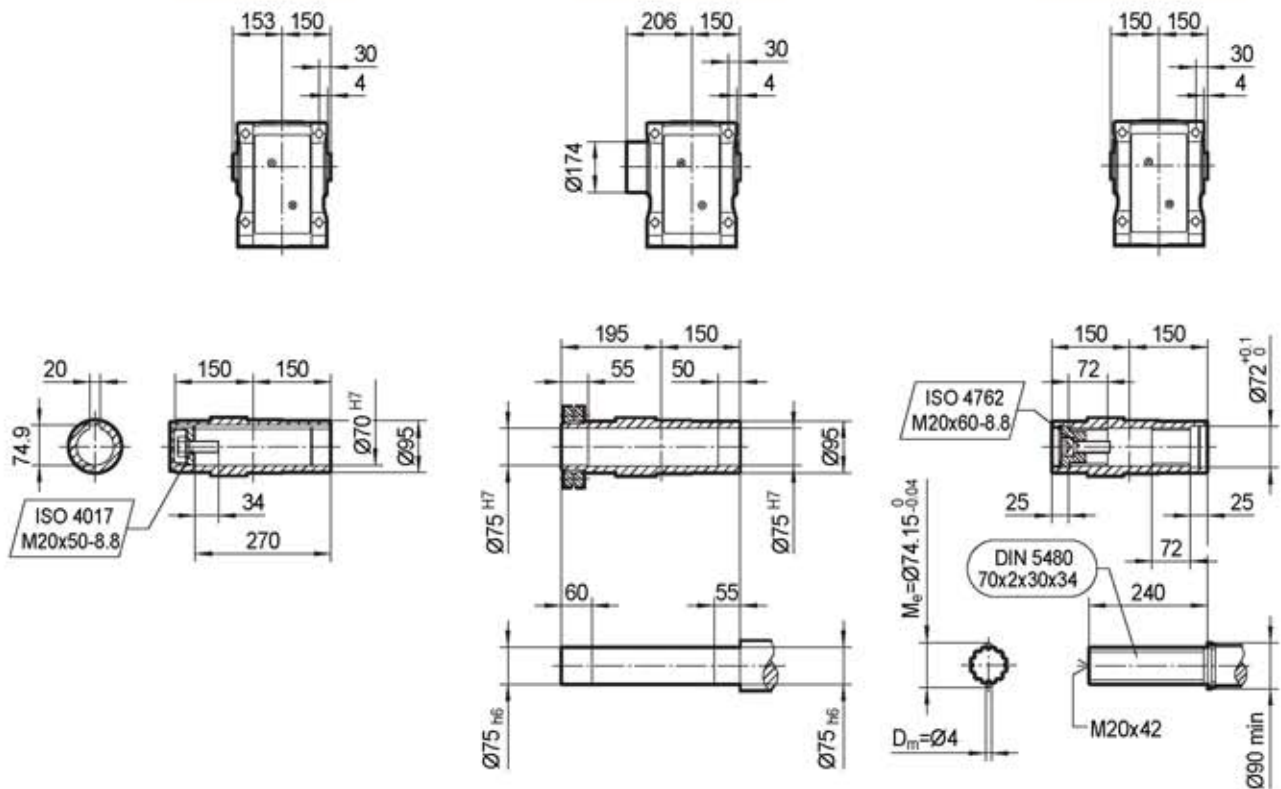

	MY90..	MY100M	MY100L	MY112M	MY132S	MY132M	MY132ML	MY160M	MY160L	MY180..	MY200..
AC	197	197	197	221	221	275	275	275	331	331	394
AD	154	166	166	179	179	230	230	230	258	258	285
AD1	161	166	166	182	182	230	230	230	258	258	285
B	251	301	331	335	380	402	462	462	509	581	629
B1	336	386	416	415	460	514	574	574	665	737	785
L	688	738	768	772	817	839	899	899	946	1018	1066
L1	773	823	853	852	897	951	1011	1011	1102	1174	1222



**TKF98..**

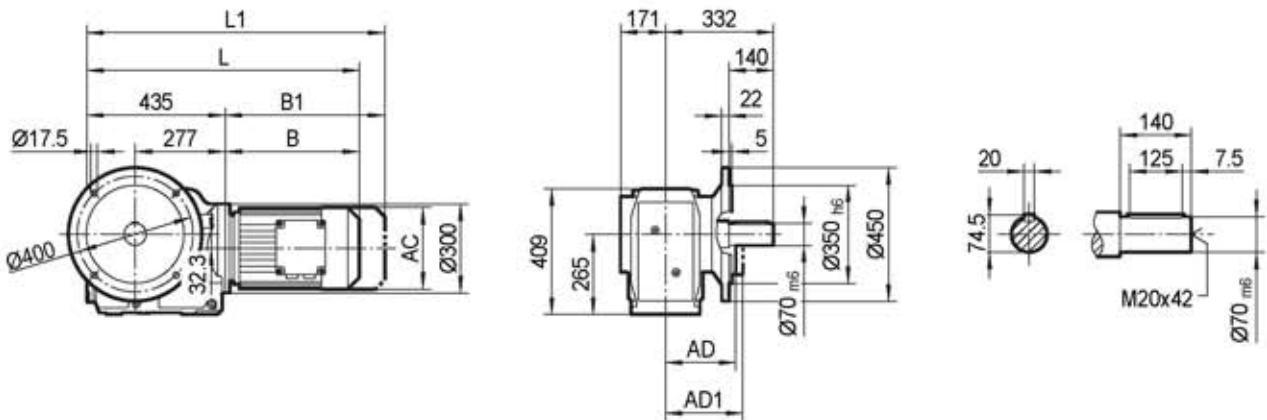

**TKAF98..**

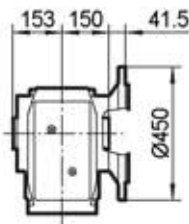

**TKHF98..**

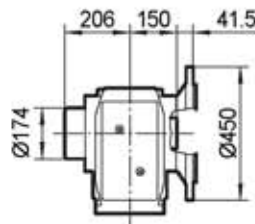

**TKVF98..**

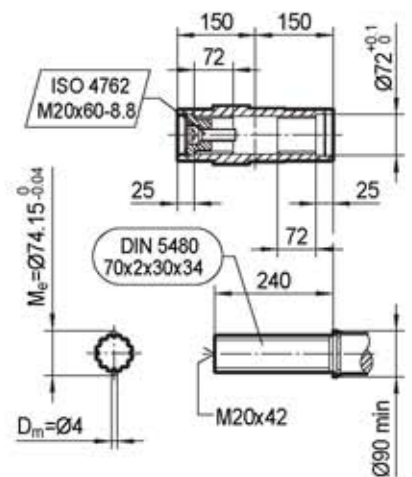
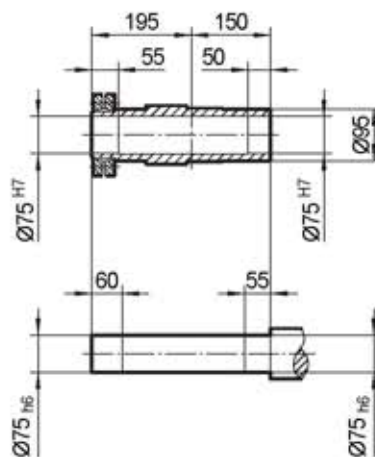
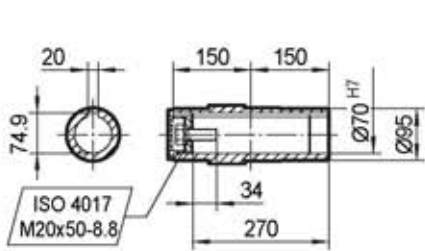
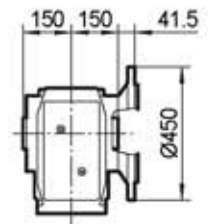

	MY90..	MY100M	MY100L	MY112M	MY132S	MY132M	MY132ML	MY160M	MY160L	MY180..	MY200..
AC	197	197	197	221	221	275	275	275	331	331	394
AD	154	166	166	179	179	230	230	230	258	258	285
AD1	161	166	166	182	182	230	230	230	258	258	285
B	251	301	331	335	380	402	462	462	509	581	629
B1	336	386	416	415	460	514	574	574	665	737	785
L	686	736	766	770	815	837	897	897	944	1016	1064
L1	771	821	851	850	895	949	1009	1009	1100	1172	1220

**TKA98..**

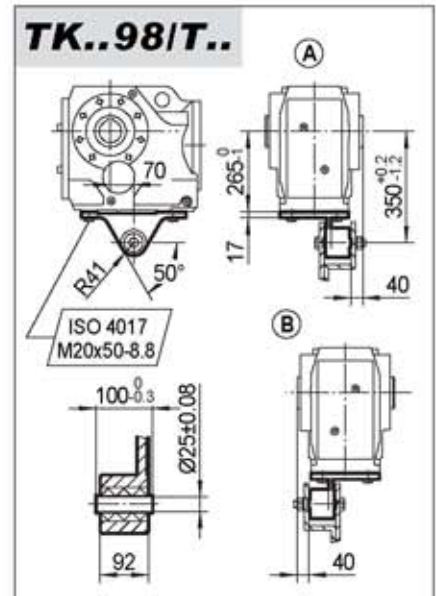
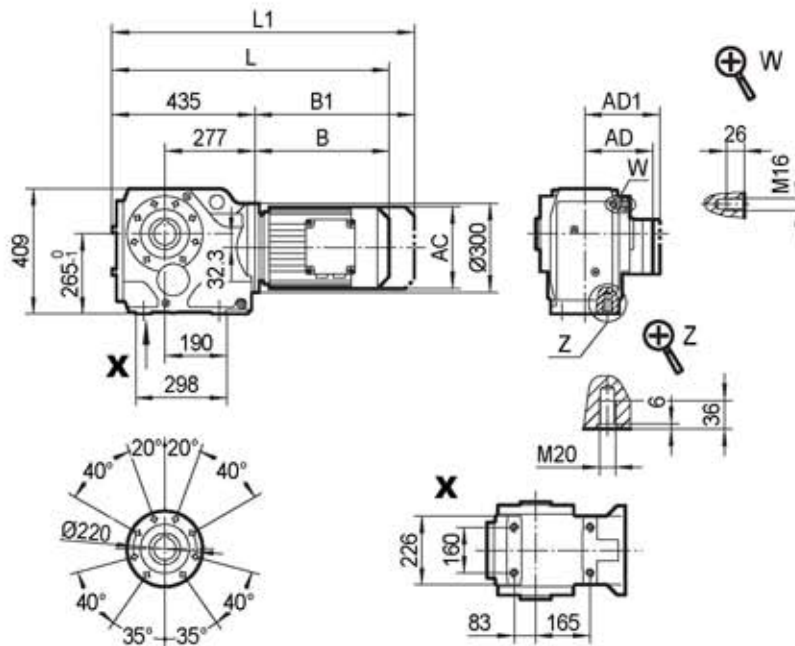

**TKA98..**

**TKH98..**

**TKV98..**

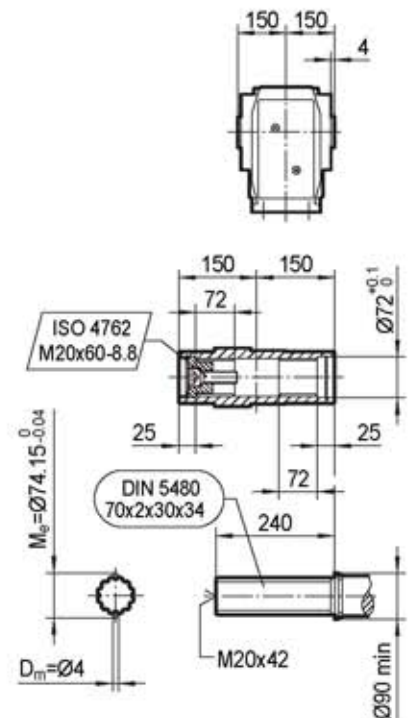
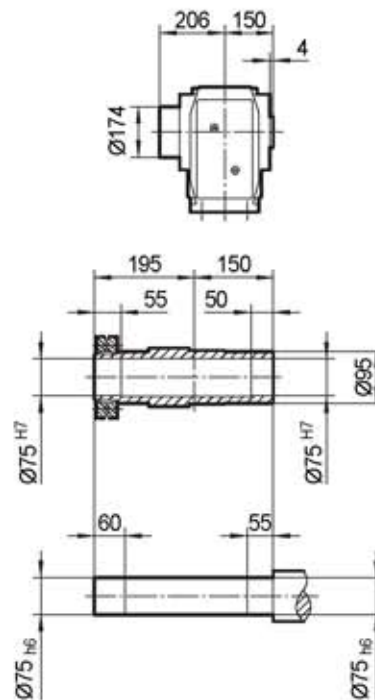
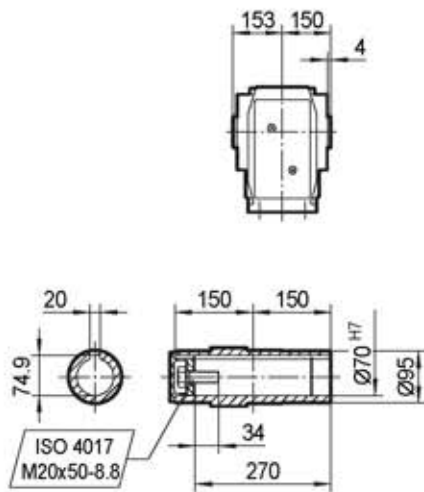

	MY90..	MY100M	MY100L	MY112M	MY132S	MY132M	MY132ML	MY160M	MY160L	MY180..	MY200..
<b>AC</b>	197	197	197	221	221	275	275	275	331	331	394
<b>AD</b>	154	166	166	179	179	230	230	230	258	258	285
<b>AD1</b>	161	166	166	182	182	230	230	230	258	258	285
<b>B</b>	251	301	331	335	380	402	462	462	509	581	629
<b>B1</b>	336	386	416	415	460	514	574	574	665	737	785
<b>L</b>	686	736	766	770	815	837	897	897	944	1016	1064
<b>L1</b>	771	821	851	850	895	949	1009	1009	1100	1172	1220

**TKAZ98..**

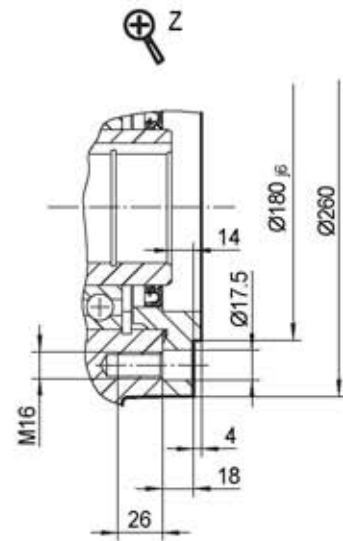
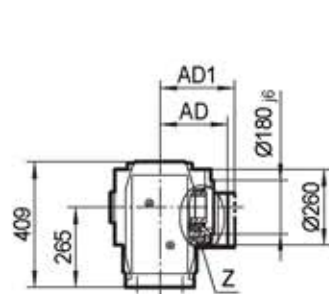
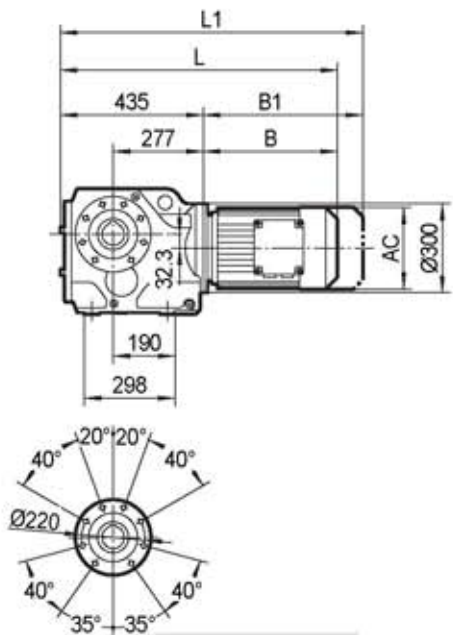

**TKAZ98..**

**TKHZ98..**

**TKVZ98..**

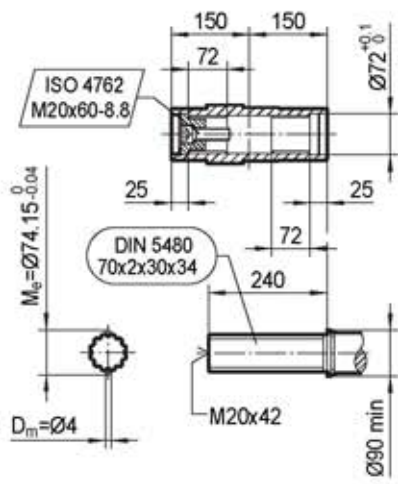
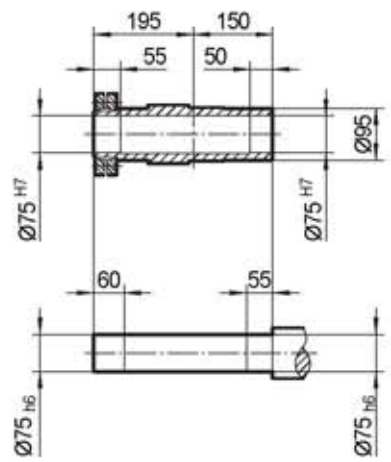
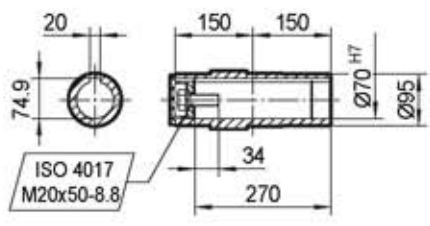
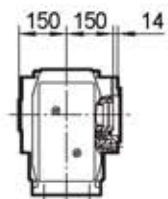
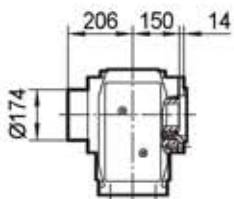
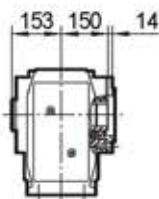

	MY90..	MY100M	MY100L	MY112M	MY132S	MY132M	MY132ML	MY160M	MY160L	MY180..	MY200..
<b>AC</b>	197	197	197	221	221	275	275	275	331	331	394
<b>AD</b>	154	166	166	179	179	230	230	230	258	258	285
<b>AD1</b>	161	166	166	182	182	230	230	230	258	258	285
<b>B</b>	251	301	331	335	380	402	462	462	509	581	629
<b>B1</b>	336	386	416	415	460	514	574	574	665	737	785
<b>L</b>	686	736	766	770	815	837	897	897	944	1016	1064
<b>L1</b>	771	821	851	850	895	949	1009	1009	1100	1172	1220



**TK108..**

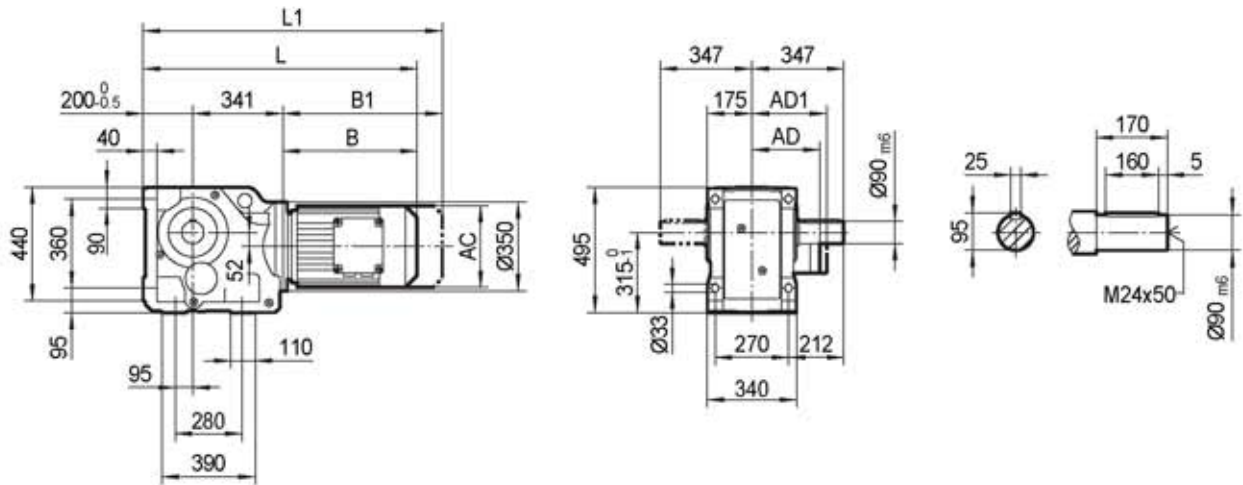

**TKA108B..**

**TKH108B..**

**TKV108B..**

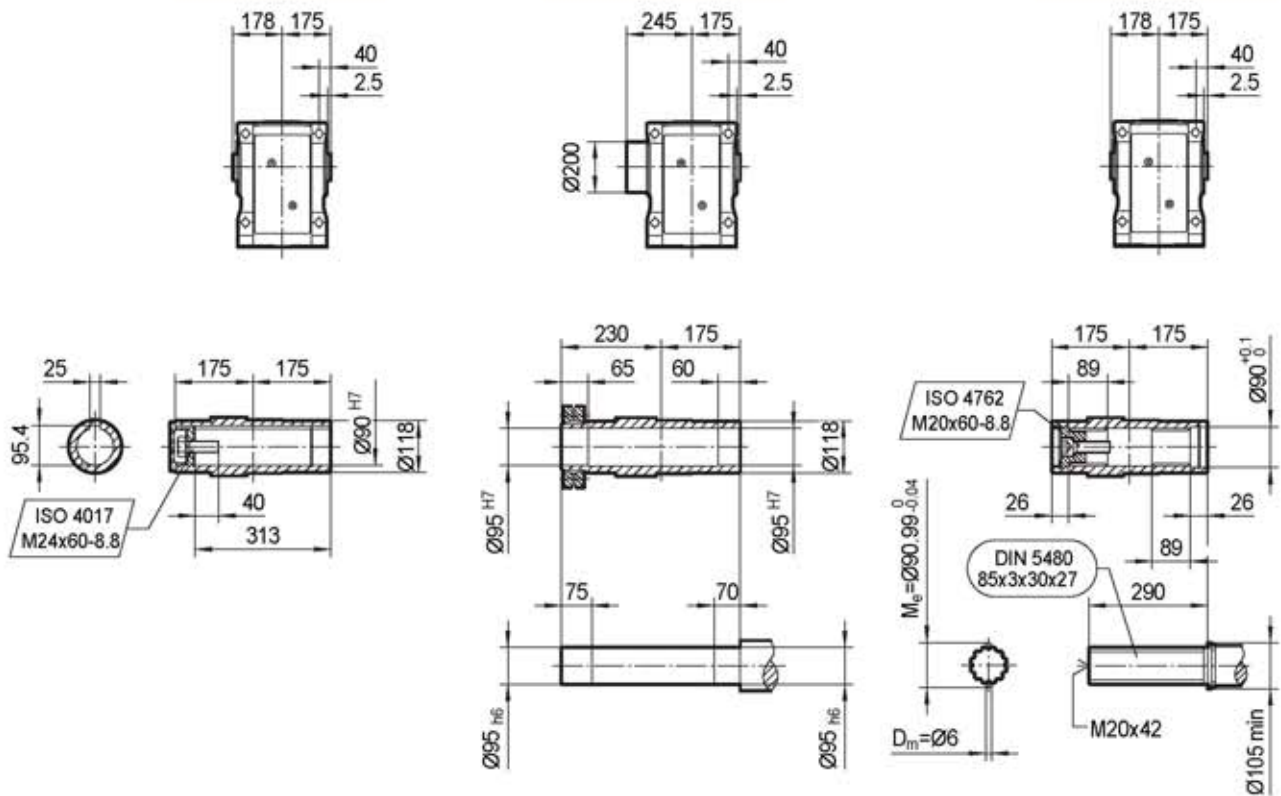

	MY100L	MY112M	MY132S	MY132M	MY132ML	MY160M	MY160L	MY180..	MY200..	MY225..
<b>AC</b>	197	221	221	275	275	275	331	331	394	394
<b>AD</b>	166	179	179	230	230	230	258	258	285	289
<b>AD1</b>	166	182	182	230	230	230	258	258	285	289
<b>B</b>	325	329	374	396	456	456	503	575	623	705
<b>B1</b>	410	409	454	508	568	568	659	731	779	861
<b>L</b>	866	870	915	937	997	997	1044	1116	1164	1246
<b>L1</b>	951	950	995	1049	1109	1109	1200	1272	1320	1402

**TKF108..**

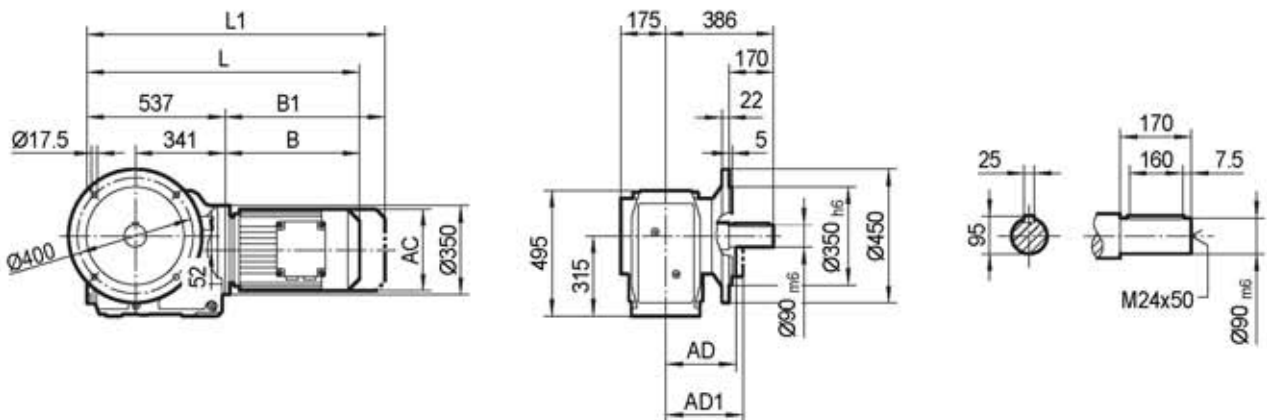

**TKAF108..**

**TKHF108..**

**TKVF108..**

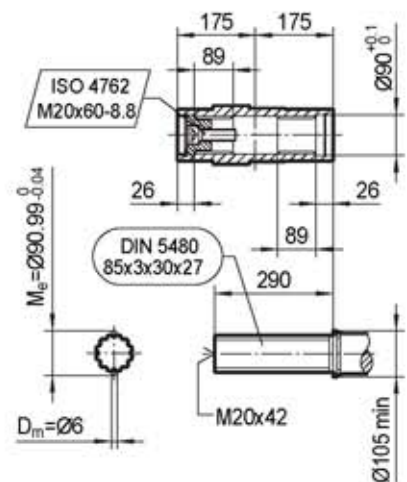
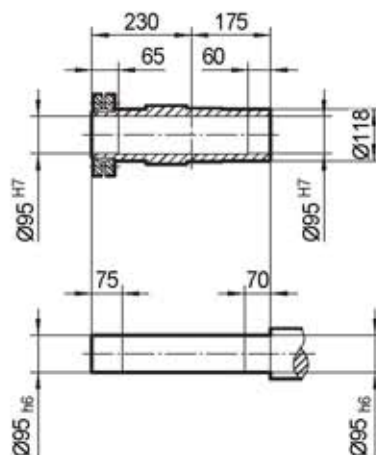
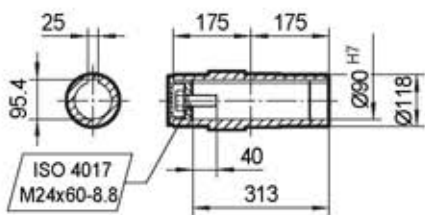
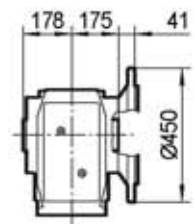
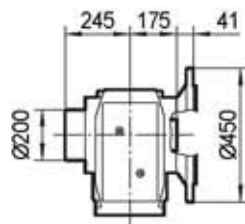
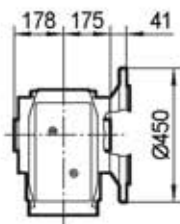

	MY100L	MY112M	MY132S	MY132M	MY132ML	MY160M	MY160L	MY180..	MY200..	MY225..
AC	197	221	221	275	275	275	331	331	394	394
AD	166	179	179	230	230	230	258	258	285	289
AD1	166	182	182	230	230	230	258	258	285	289
B	325	329	374	396	456	456	503	575	623	705
B1	410	409	454	508	568	568	659	731	779	861
L	862	866	911	933	993	993	1040	1112	1160	1242
L1	947	946	991	1045	1105	1105	1196	1268	1316	1398

**TKA108..**

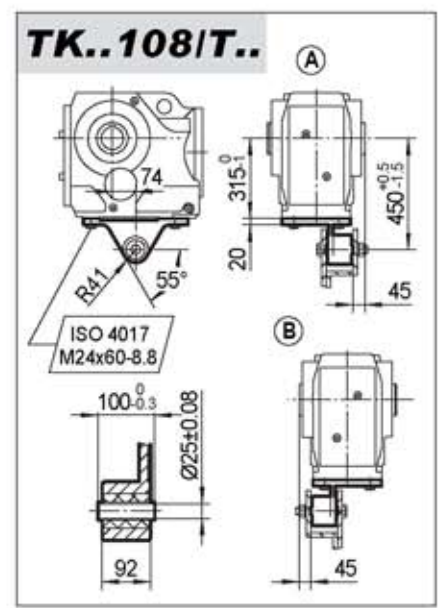
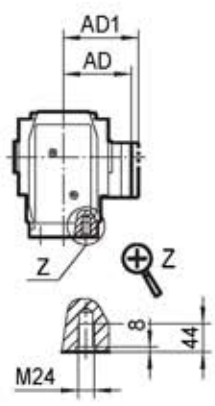
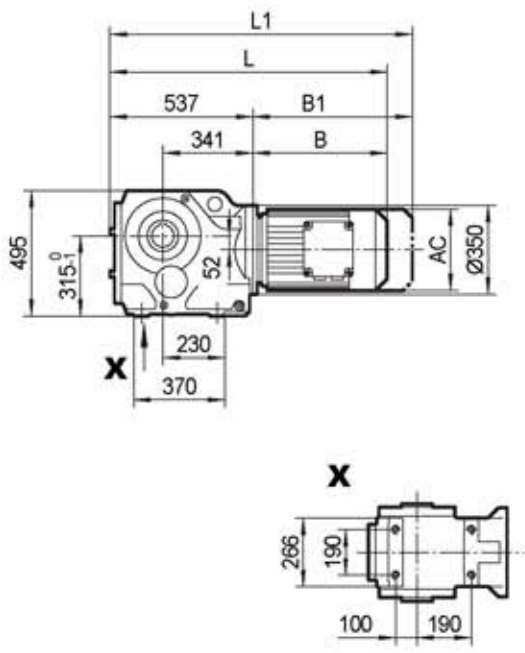

**TKA108..**

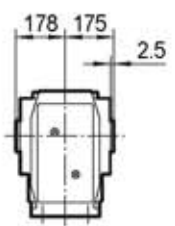

**TKH108..**

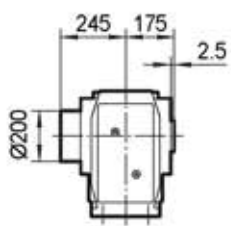

**TKV108..**

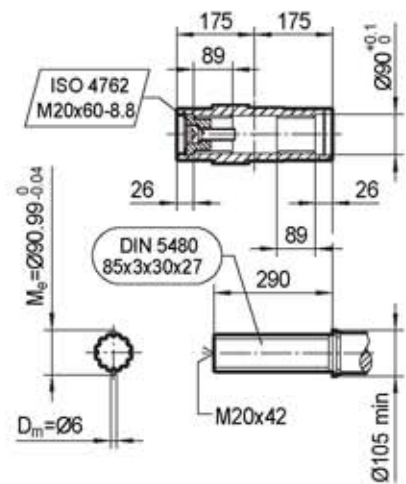
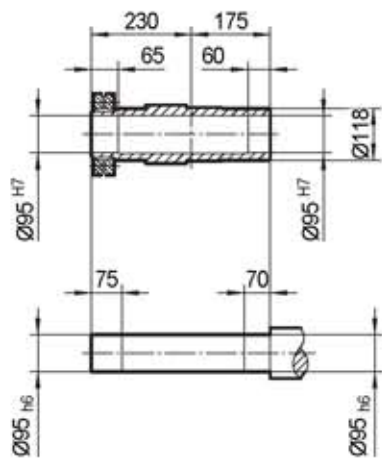
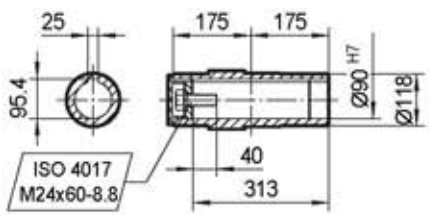
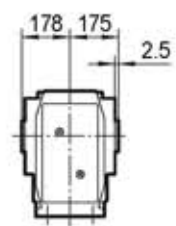

	MY100L	MY112M	MY132S	MY132M	MY132ML	MY160M	MY160L	MY180..	MY200..	MY225..
<b>AC</b>	197	221	221	275	275	275	331	331	394	394
<b>AD</b>	166	179	179	230	230	230	258	258	285	289
<b>AD1</b>	166	182	182	230	230	230	258	258	285	289
<b>B</b>	325	329	374	396	456	456	503	575	623	705
<b>B1</b>	410	409	454	508	568	568	659	731	779	861
<b>L</b>	862	866	911	933	993	993	1040	1112	1160	1242
<b>L1</b>	947	946	991	1045	1105	1105	1196	1268	1316	1398



**TKAZ108..**

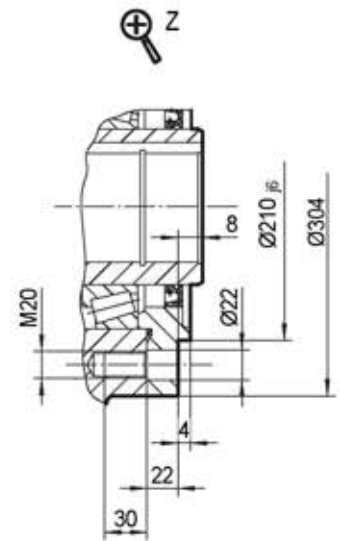
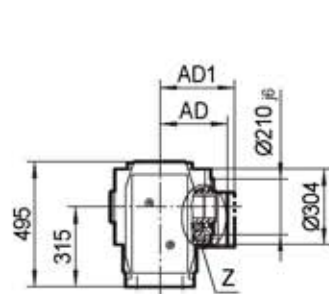
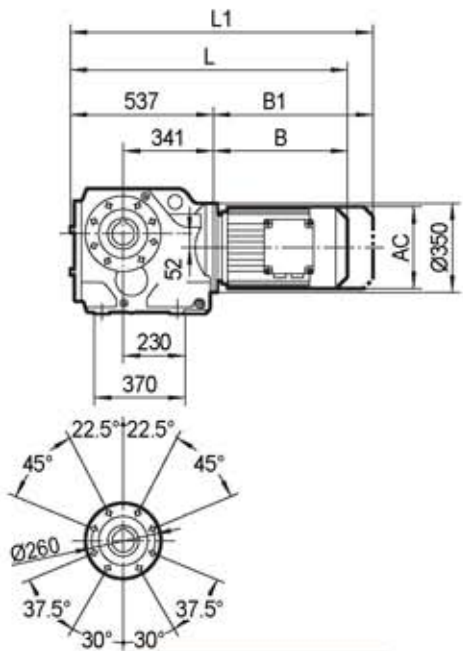

**TKAZ108..**

**TKHZ108..**

**TKVZ108..**

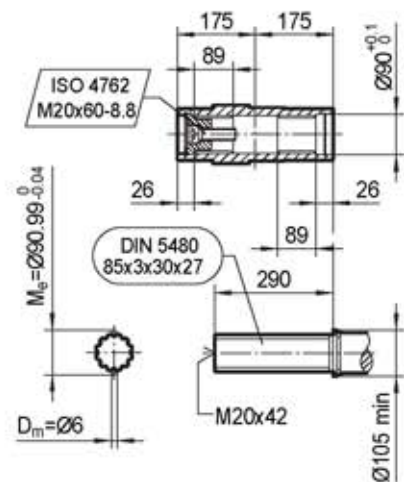
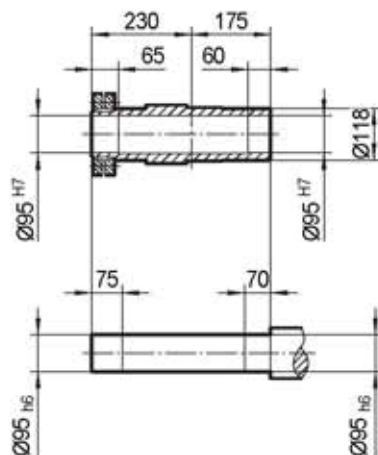
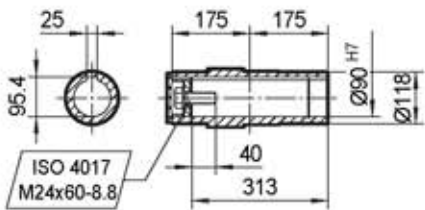
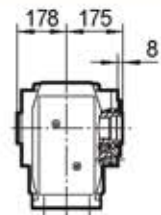
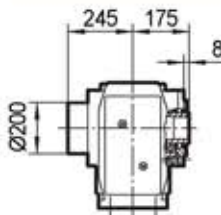
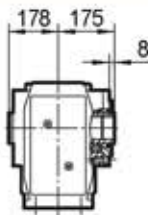

	MY100L	MY112M	MY132S	MY132M	MY132ML	MY160M	MY160L	MY180..	MY200..	MY225..	
<b>AC</b>	197	221	221	275	275	275	331	331	394	394	
<b>AD</b>	166	179	179	230	230	230	258	258	285	289	
<b>AD1</b>	166	182	182	230	230	230	258	258	285	289	
<b>B</b>	325	329	374	396	456	456	503	575	623	705	
<b>B1</b>	410	409	454	508	568	568	659	731	779	861	
<b>L</b>	862	866	911	933	993	993	1040	1112	1160	1242	
<b>L1</b>	947	946	991	1045	1105	1105	1196	1268	1316	1398	

**TK128..**

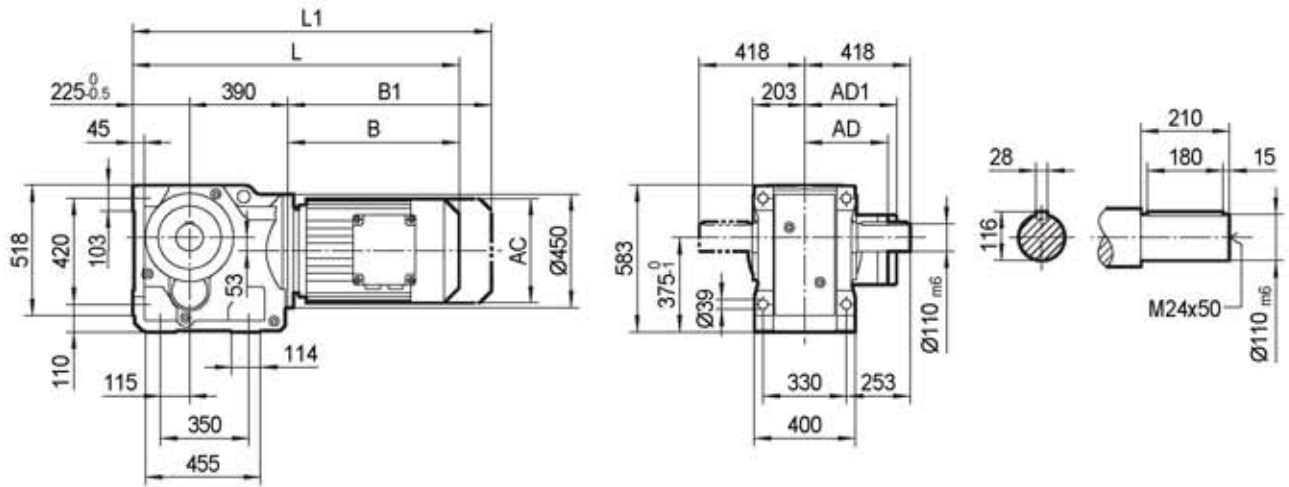

**TKA128B..**

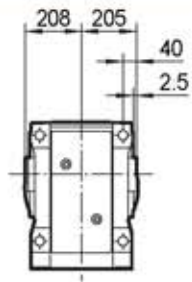

**TKH128B..**

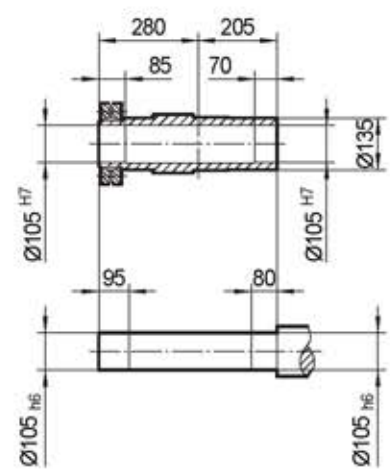
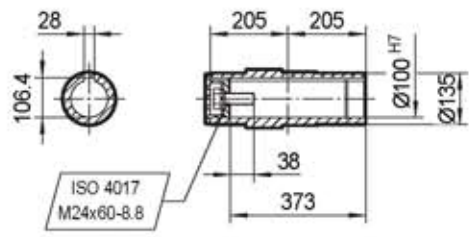
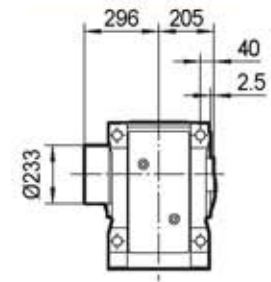

	MY132M	MY132ML	MY160M	MY160L	MY180..	MY200..	MY225..	MY250M	MY280..		
<b>AC</b>	275	275	275	331	331	394	394	510	510		
<b>AD</b>	230	230	230	258	258	285	289	397	397		
<b>AD1</b>	230	230	230	258	258	285	289	397	397		
<b>B</b>	381	441	441	488	560	608	690	780	780		
<b>B1</b>	493	553	553	644	716	764	846	965	965		
<b>L</b>	996	1056	1056	1103	1175	1223	1305	1395	1395		
<b>L1</b>	1108	1168	1168	1259	1331	1379	1461	1580	1580		

**TKF128..**

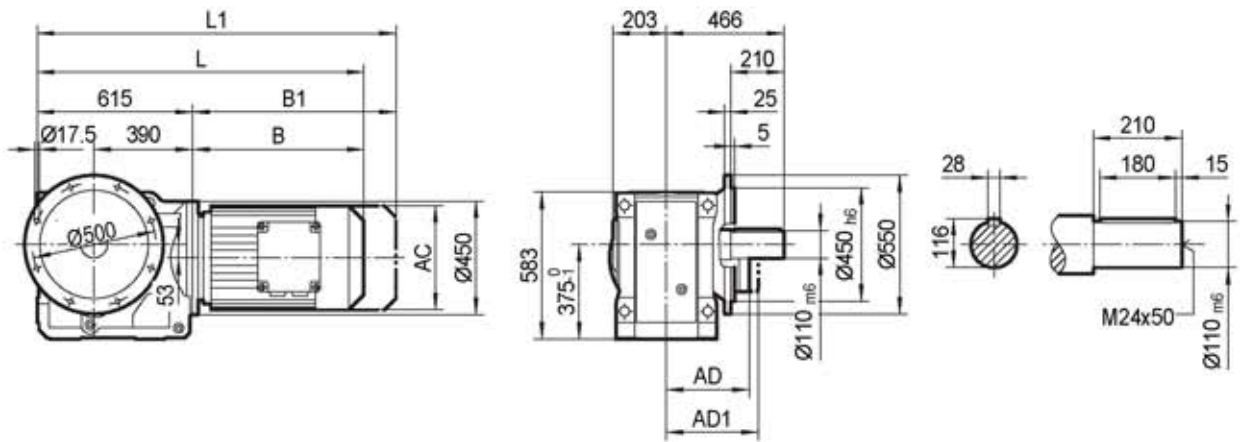

**TKAF128..**

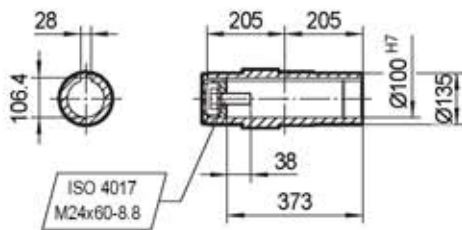
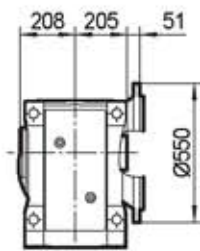

**TKHF128..**

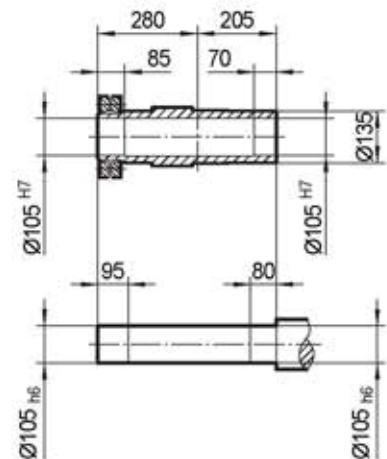
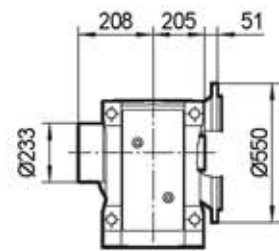

	MY132M	MY132ML	MY160M	MY160L	MY180..	MY200..	MY225..	MY250M	MY280..		
AC	275	275	275	331	331	394	394	510	510		
AD	230	230	230	258	258	285	289	397	397		
AD1	230	230	230	258	258	285	289	397	397		
B	381	441	441	488	560	608	690	780	780		
B1	493	553	553	644	716	764	846	965	965		
L	996	1056	1056	1103	1175	1223	1305	1395	1395		
L1	1108	1168	1168	1259	1331	1379	1461	1580	1580		



**TKA128..**

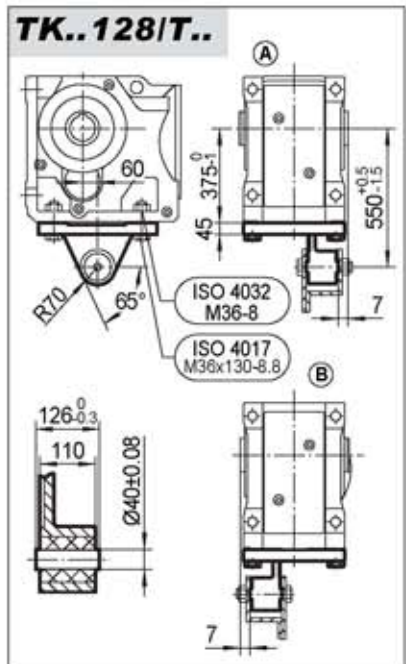
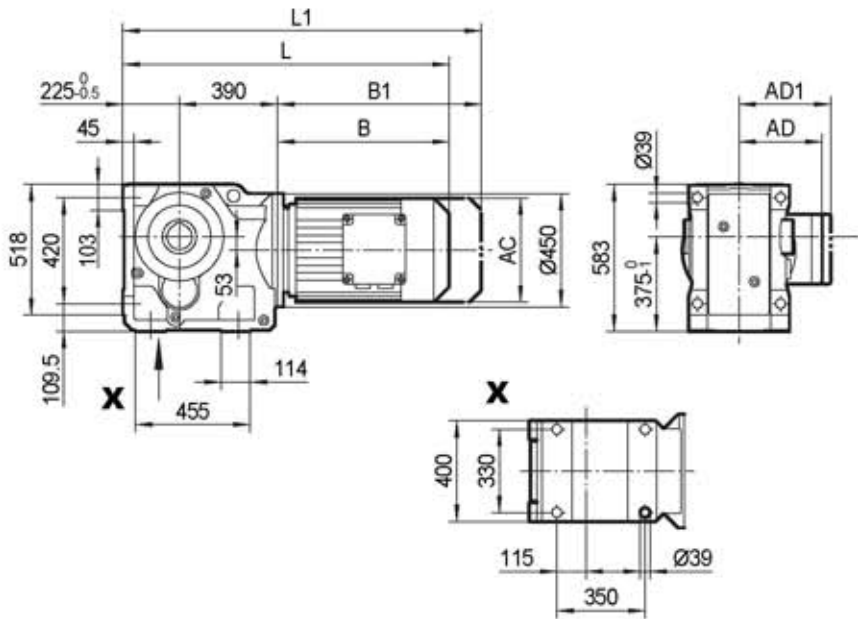

**TKA128..**

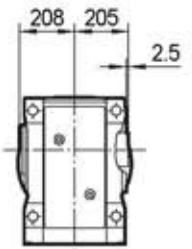

**TKH128..**

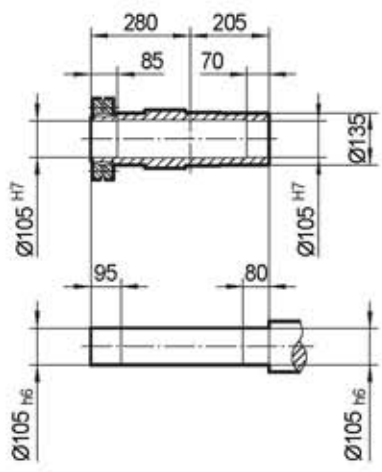
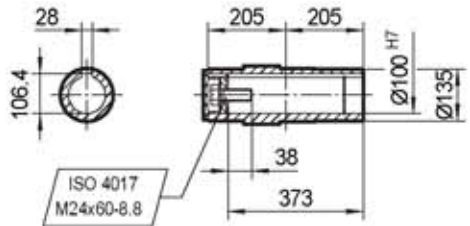
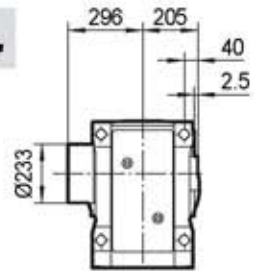

	MY132M	MY132ML	MY160M	MY160L	MY180..	MY200..	MY225..	MY250M	MY280..		
<b>AC</b>	275	275	275	331	331	394	394	510	510		
<b>AD</b>	230	230	230	258	258	285	289	397	397		
<b>AD1</b>	230	230	230	258	258	285	289	397	397		
<b>B</b>	381	441	441	488	560	608	690	780	780		
<b>B1</b>	493	553	553	644	716	764	846	965	965		
<b>L</b>	996	1056	1056	1103	1175	1223	1305	1395	1395		
<b>L1</b>	1108	1168	1168	1259	1331	1379	1461	1580	1580		

**TKAZ128..**

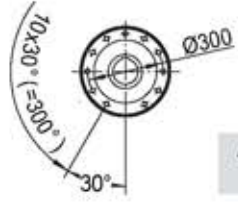
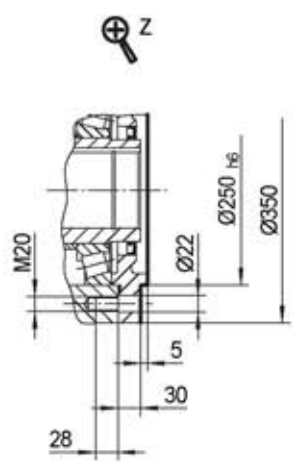
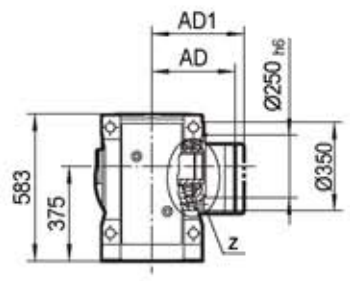
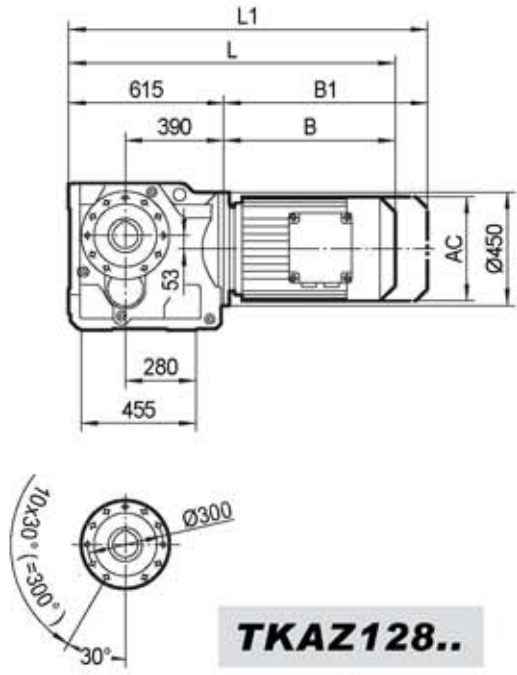

**TKAZ128..**

**TKHZ128..**

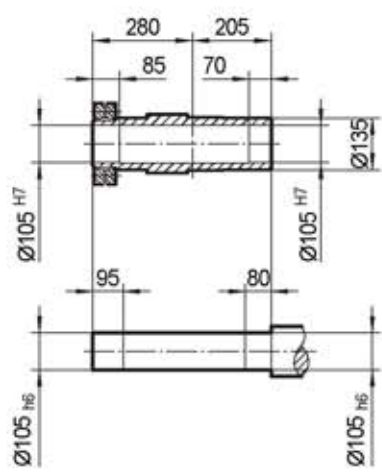
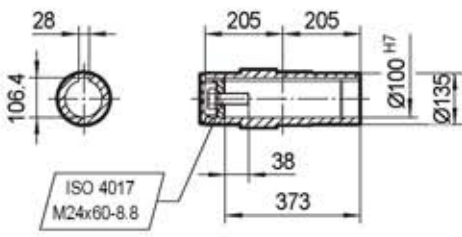
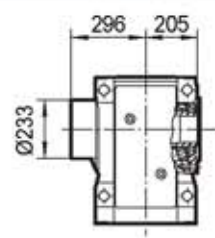
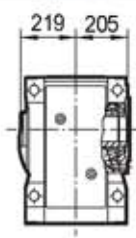

	MY132M	MY132ML	MY160M	MY160L	MY180..	MY200..	MY225..	MY250M	MY280..		
<b>AC</b>	275	275	275	331	331	394	394	510	510		
<b>AD</b>	230	230	230	258	258	285	289	397	397		
<b>AD1</b>	230	230	230	258	258	285	289	397	397		
<b>B</b>	381	441	441	488	560	608	690	780	780		
<b>B1</b>	493	553	553	644	716	764	846	965	965		
<b>L</b>	996	1056	1056	1103	1175	1223	1305	1395	1395		
<b>L1</b>	1108	1168	1168	1259	1331	1379	1461	1580	1580		

**TK158..**

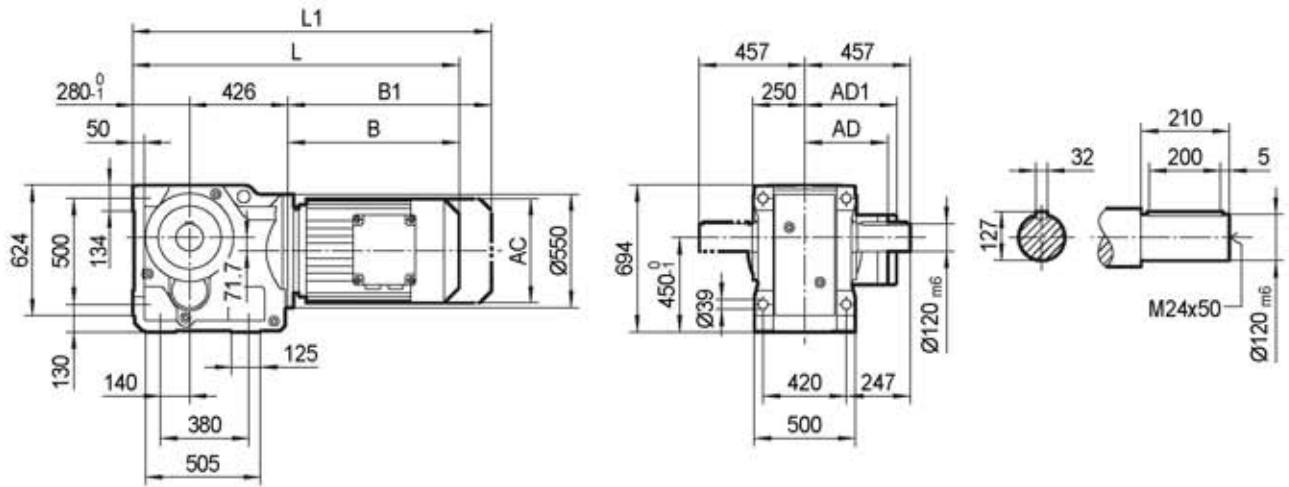

**TKA158B..**

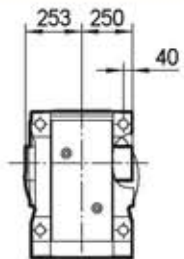

**TKH158B..**

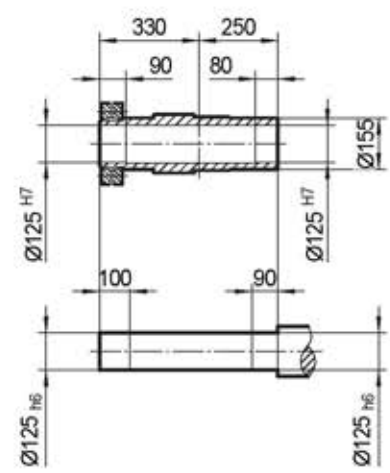
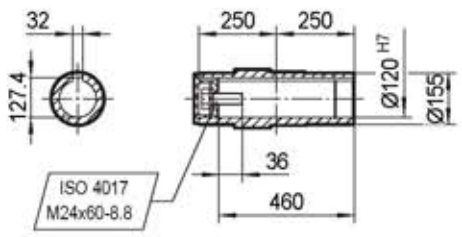
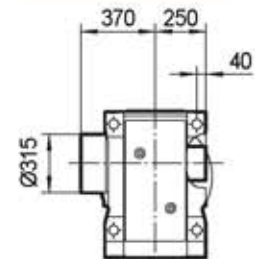

	MY160M	MY160L	MY180..	MY200..	MY225..	MY250M	MY280..	MY315S	MY315M		
<b>AC</b>	275	331	331	394	394	510	510	612	612		
<b>AD</b>	230	258	258	285	289	397	397	430	430		
<b>AD1</b>	230	258	258	285	289	397	397	430	430		
<b>B</b>	433	480	552	600	682	771	771	999	1050		
<b>B1</b>	545	636	708	756	838	956	956	1210	1261		
<b>L</b>	1139	1186	1258	1306	1388	1477	1477	1705	1756		
<b>L1</b>	1251	1342	1414	1462	1544	1662	1662	1916	1967		



**TKF158..**

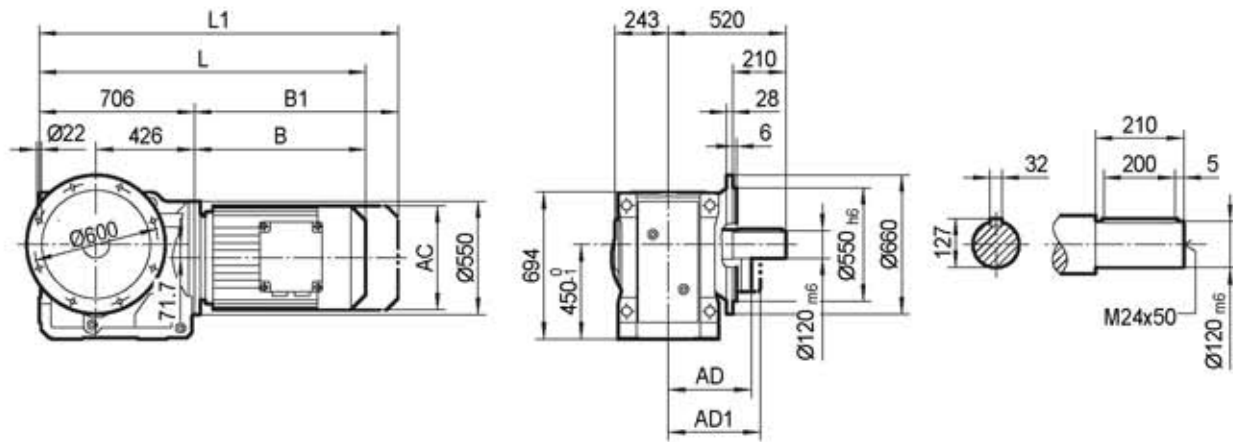

**TKAF158..**

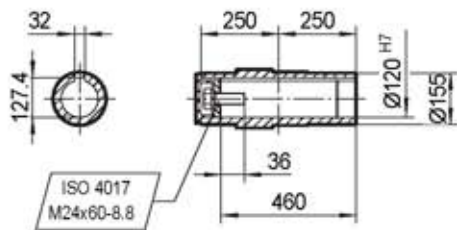
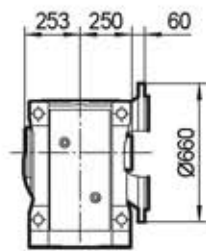

**TKHF158..**

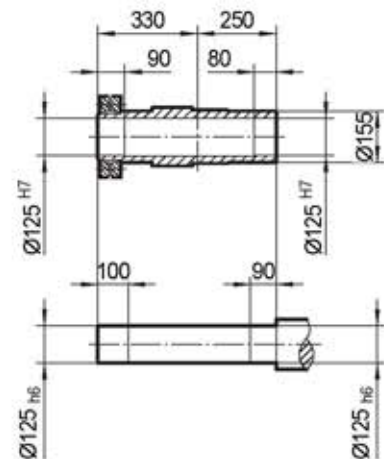
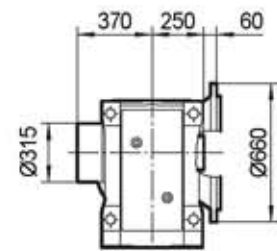

	MY160M	MY160L	MY180..	MY200..	MY225..	MY250M	MY280..	MY316S	MY316M		
AC	275	331	331	394	394	510	510	612	612		
AD	230	258	258	285	289	397	397	430	430		
AD1	230	258	258	285	289	397	397	430	430		
B	433	480	552	600	682	771	771	999	1050		
B1	545	636	708	756	838	956	956	1210	1261		
L	1139	1186	1258	1306	1388	1477	1477	1705	1756		
L1	1251	1342	1414	1462	1544	1662	1662	1916	1967		

**TKA158..**

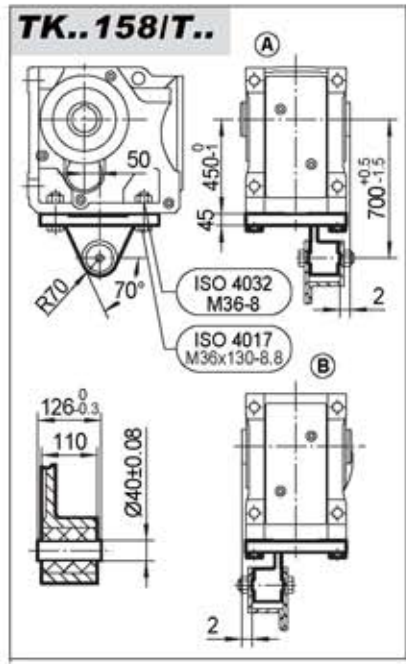
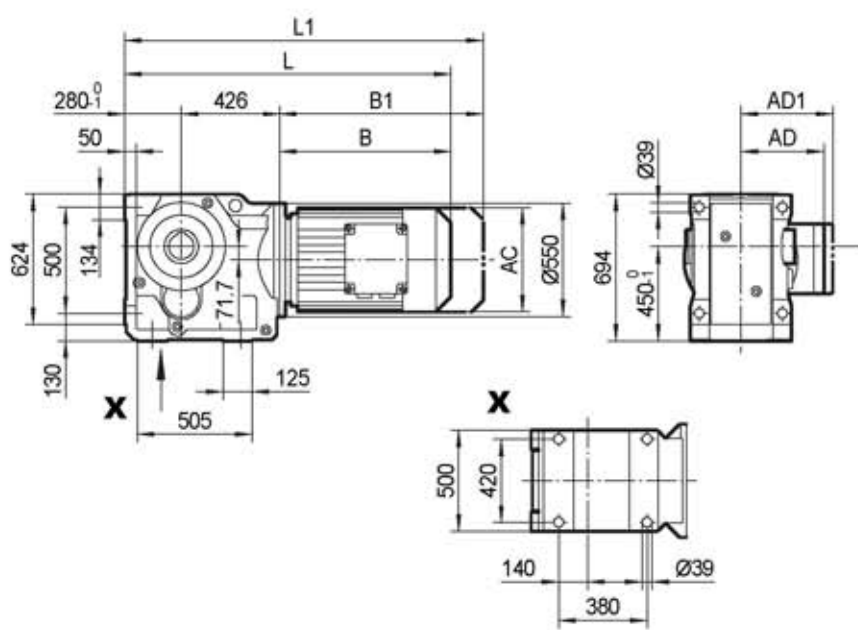

**TKA158..**

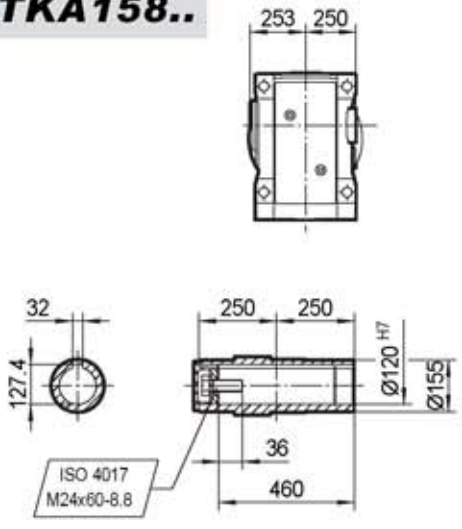

**TKH158..**

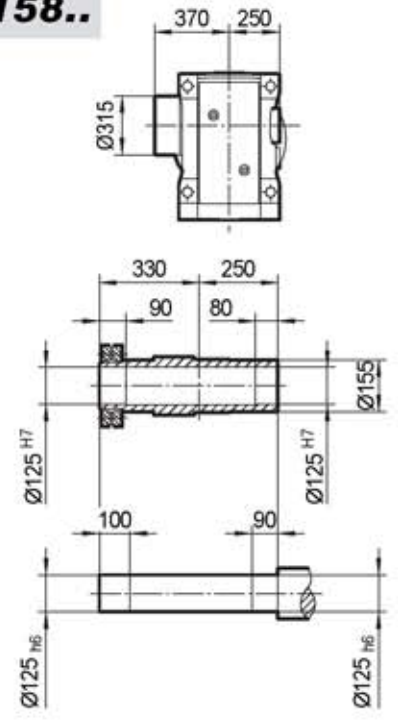

	MY160M	MY160L	MY180..	MY200..	MY225..	MY250M	MY280..	MY316S	MY316M		
<b>AC</b>	275	331	331	394	394	510	510	612	612		
<b>AD</b>	230	258	258	285	289	397	397	430	430		
<b>AD1</b>	230	258	258	285	289	397	397	430	430		
<b>B</b>	433	480	552	600	682	771	771	999	1050		
<b>B1</b>	545	636	708	756	838	956	956	1210	1261		
<b>L</b>	1139	1186	1258	1306	1388	1477	1477	1705	1756		
<b>L1</b>	1251	1342	1414	1462	1544	1662	1662	1916	1967		

**TKAZ158..**

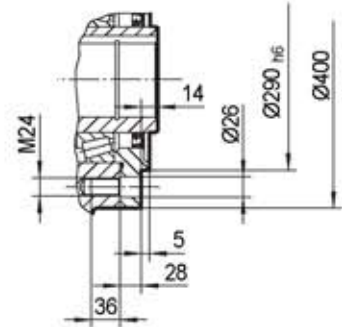
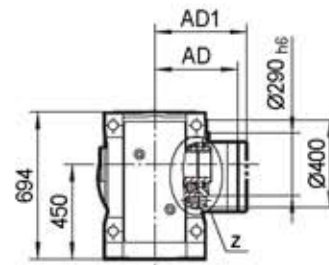
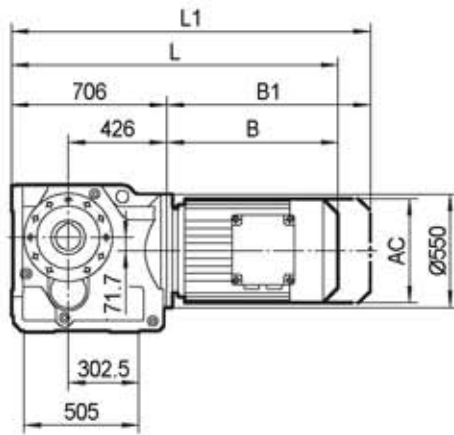

**TKAZ158..**

**TKHZ158..**

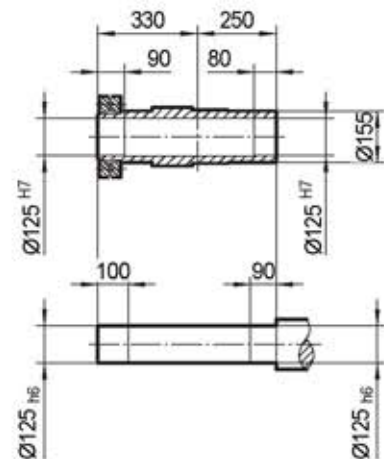
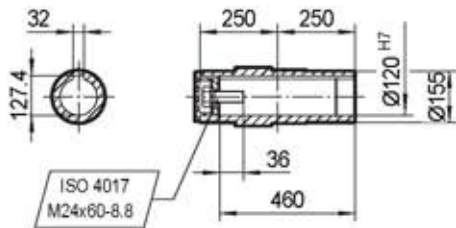
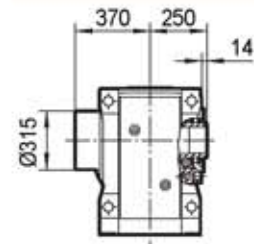
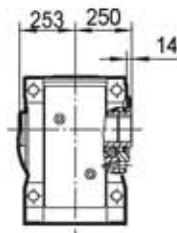

	MY160M	MY160L	MY180..	MY200..	MY225..	MY250M	MY280..	MY316S	MY316M		
AC	275	331	331	394	394	510	510	612	612		
AD	230	258	258	285	289	397	397	430	430		
AD1	230	258	258	285	289	397	397	430	430		
B	433	480	552	600	682	771	771	999	1050		
B1	545	636	708	756	838	956	956	1210	1261		
L	1139	1186	1258	1306	1388	1477	1477	1705	1756		
L1	1251	1342	1414	1462	1544	1662	1662	1916	1967		



**TK168..**

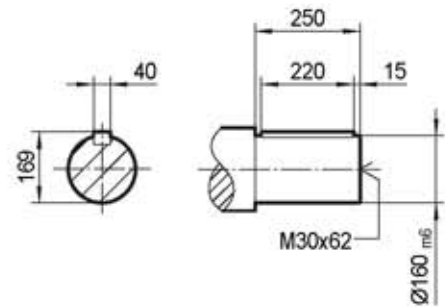
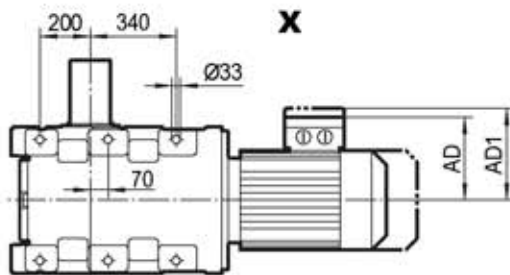
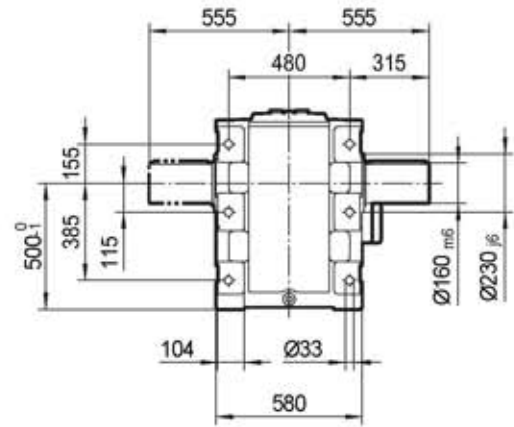
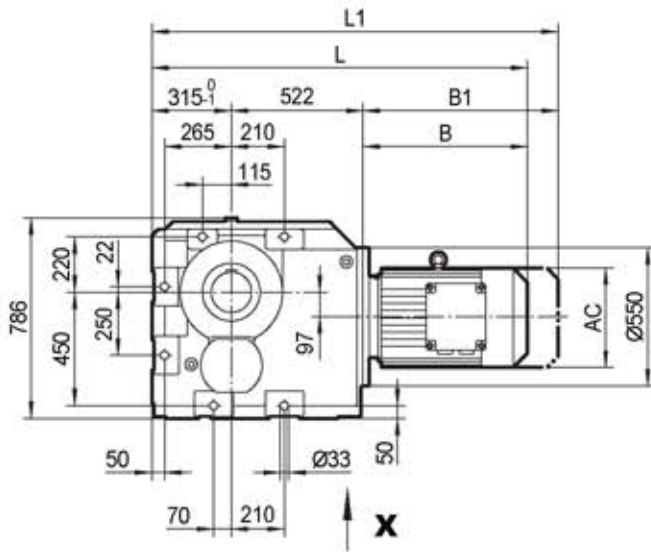

**TKH168B..**

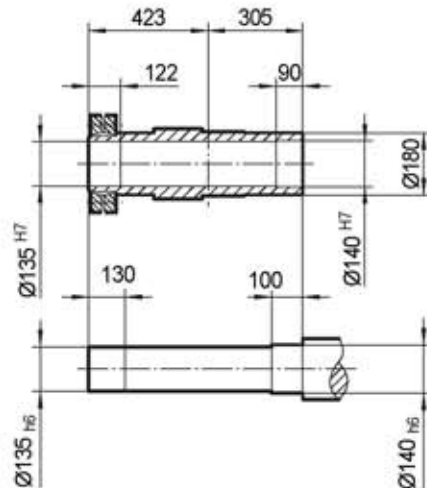
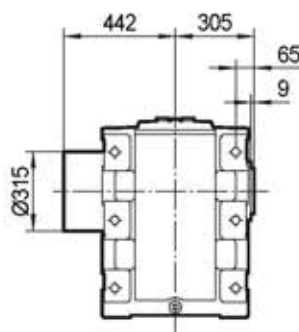

	MY160M	MY160L	MY180..	MY200..	MY225..	MY250M	MY280..	MY315S	MY315M		
<b>AC</b>	275	331	331	394	394	510	510	612	612		
<b>AD</b>	230	258	258	285	289	397	397	430	430		
<b>AD1</b>	230	258	258	285	289	397	397	430	430		
<b>B</b>	433	480	552	600	682	771	771	999	1050		
<b>B1</b>	545	636	708	756	838	956	956	1210	1261		
<b>L</b>	1270	1317	1389	1437	1519	1608	1608	1836	1887		
<b>L1</b>	1382	1473	1545	1593	1675	1793	1793	2047	2098		

**TKH168..**

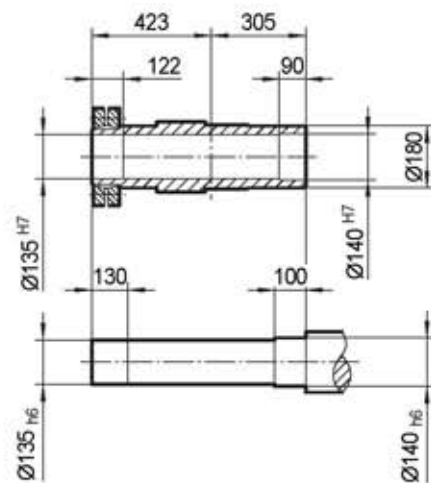
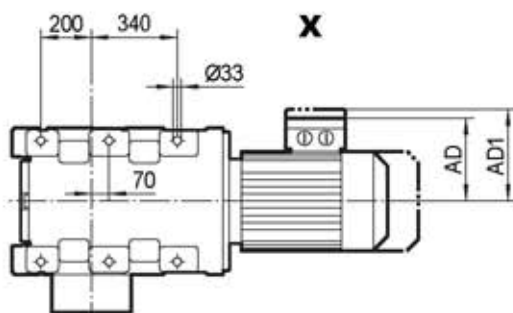
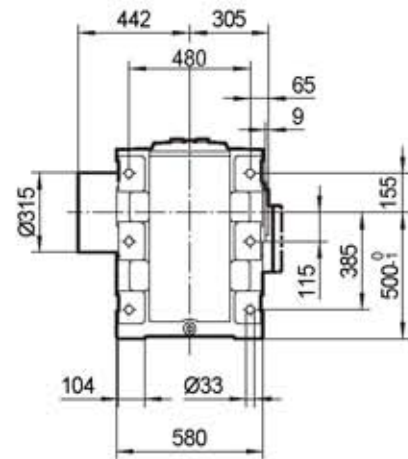
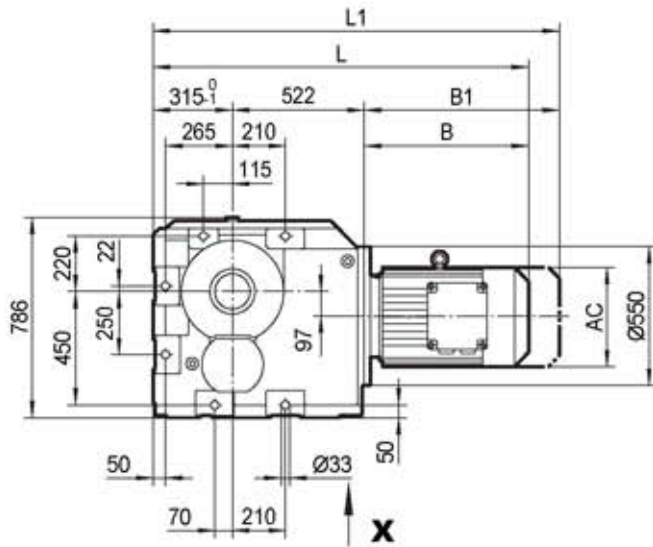

	MY160M	MY160L	MY180..	MY200..	MY225..	MY250M	MY280..	MY316S	MY316M		
AC	275	331	331	394	394	510	510	612	612		
AD	230	258	258	285	289	397	397	430	430		
AD1	230	258	258	285	289	397	397	430	430		
B	433	480	552	600	682	771	771	999	1050		
B1	545	636	708	756	838	956	956	1210	1261		
L	1270	1317	1389	1437	1519	1608	1608	1836	1887		
L1	1382	1473	1545	1593	1675	1793	1793	2047	2098		

**TK188..**

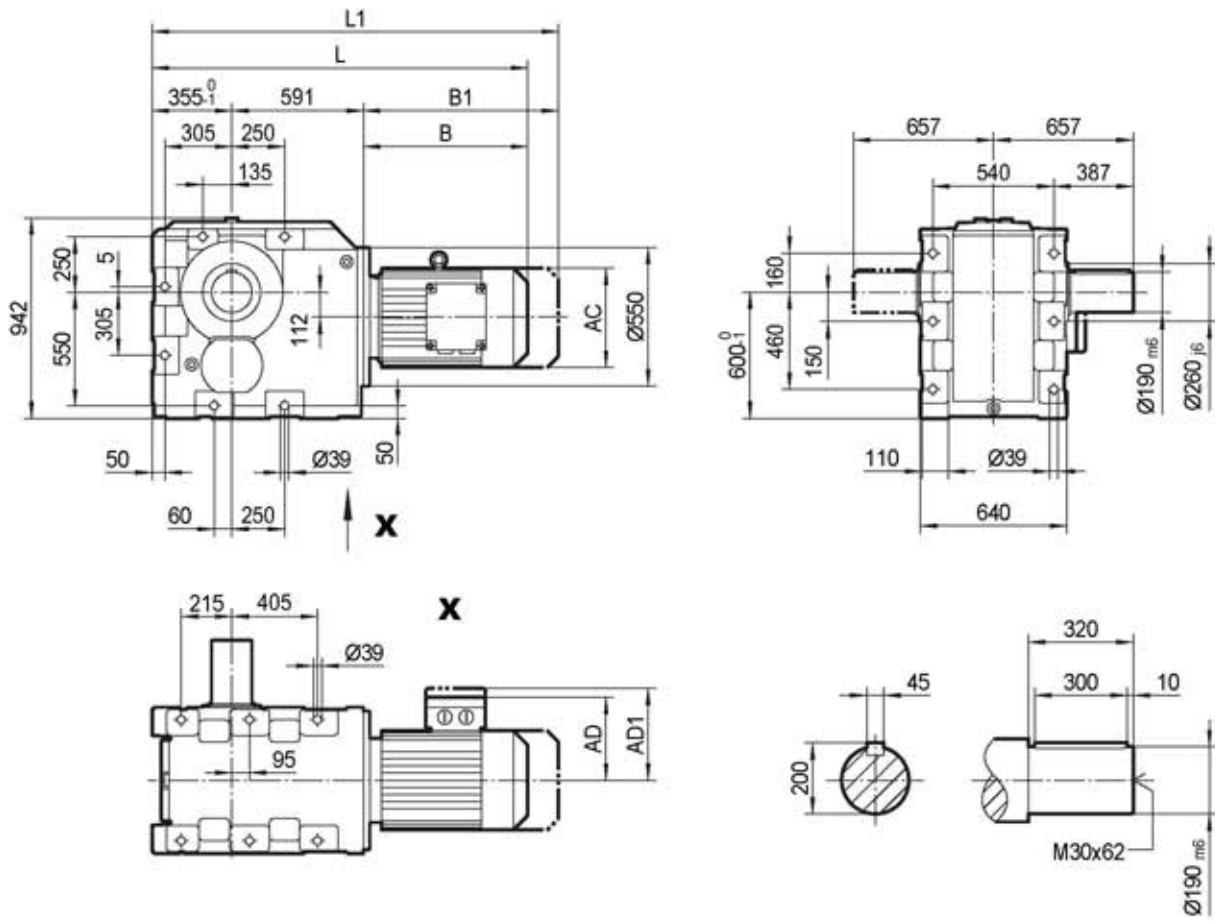

**TKH188B..**

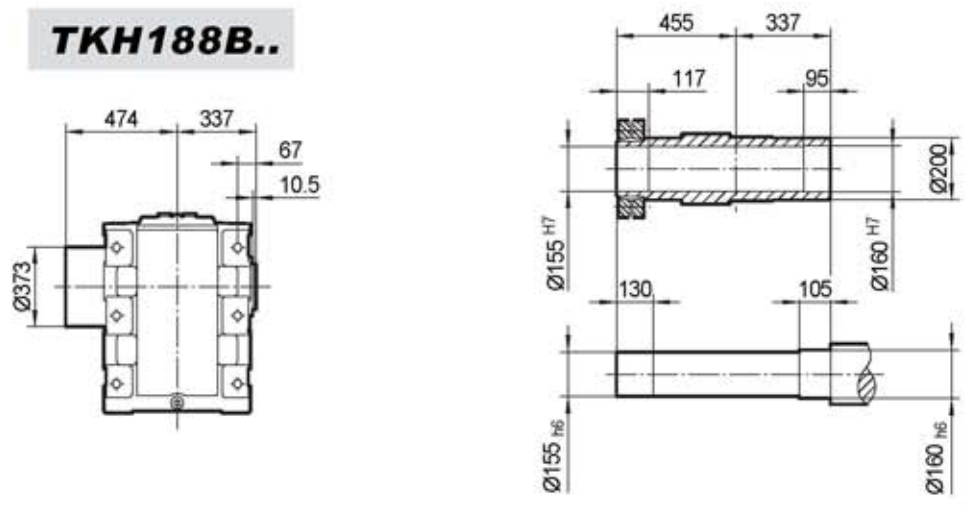

	MY180..	MY200..	MY225..	MY250M	MY280..	MY315S	MY315M			
AC	331	394	394	510	510	612	612			
AD	258	285	289	397	397	430	430			
AD1	258	285	289	397	397	430	430			
B	552	600	682	771	771	999	1050			
B1	708	756	838	956	956	1210	1261			
L	1498	1546	1628	1717	1717	1945	1996			
L1	1654	1702	1784	1902	1902	2156	2207			



**TKH188..**

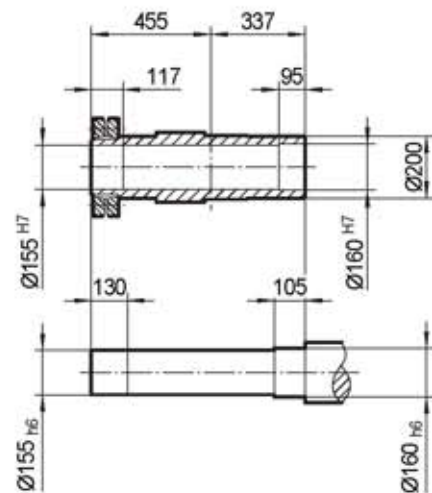
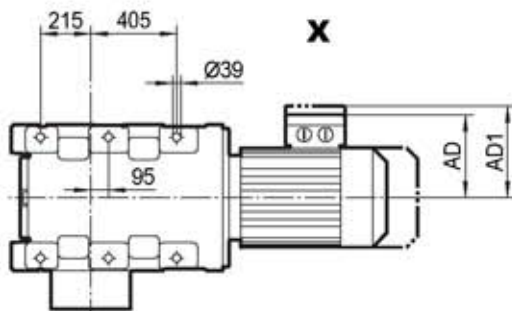
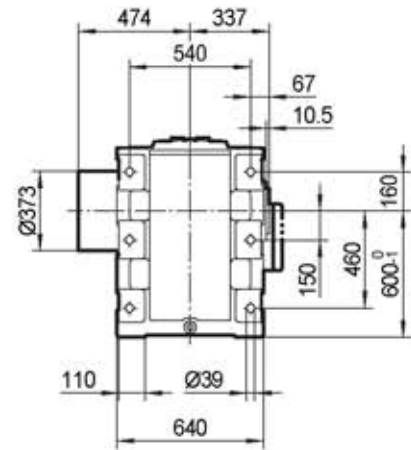
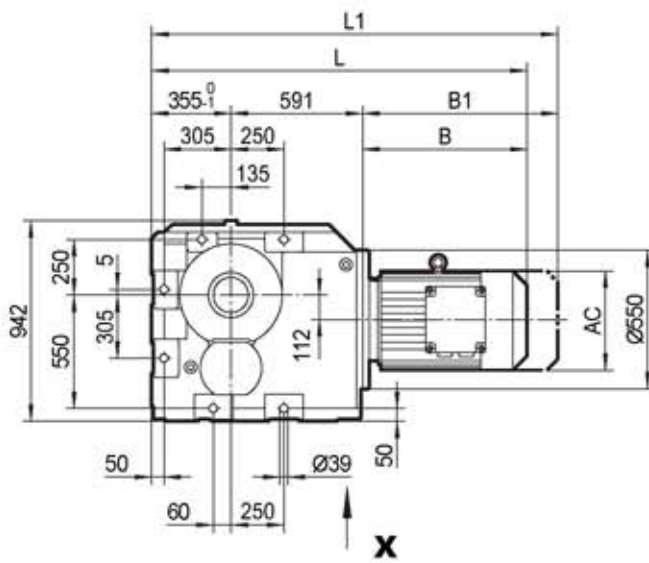

	MY180..	MY200..	MY225..	MY250M	MY280..	MY316S	MY316M			
AC	331	394	394	510	510	612	612			
AD	258	285	289	397	397	430	430			
AD1	258	285	289	397	397	430	430			
B	552	600	682	771	771	999	1050			
B1	708	756	838	956	956	1210	1261			
L	1498	1546	1628	1717	1717	1945	1996			
L1	1654	1702	1784	1902	1902	2156	2207			

**7.2 TK../TRF Outline Dimension**

**TK../TRF..**

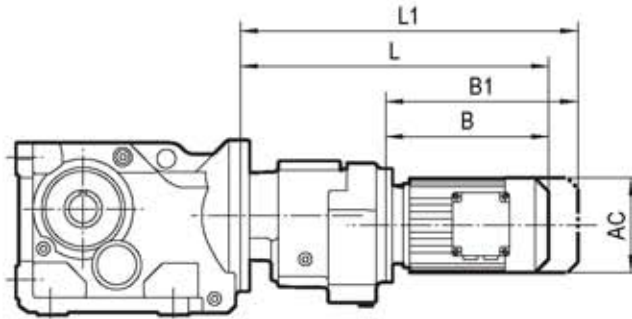

TK../TRF..	MY..	AC	L	L1	B	B1
TK..38/TRF18	MY63..	132	324	379	149	204
	MY71D	145	339	403	164	228
	MY80..	145	389	453	214	278
TK..48/TRF38	MY63..	132	356	411	191	246
	MY71D	145	371	435	206	270
	MY80..	145	421	485	256	320
TK..58/TRF38 TK..68/TRF38	MY63..	132	356	411	191	246
	MY71D	145	371	435	206	270
	MY80..	145	421	485	256	320
TK..78/TRF38	MY90..	197	441	526	276	361
	MY63..	132	348	403	191	246
	MY71D	145	363	427	206	270
TK..88/TRF58	MY80..	145	413	477	256	320
	MY90..	197	433	518	276	361
	MY63..	132	401	456	185	240
TK..88/TRF58	MY71D	145	415	479	199	263
	MY80..	145	465	529	249	313
	MY90..	197	485	570	269	354
	MY100M	197	535	620	319	404
	MY100L	197	565	650	349	434
	MY100L	197	565	645	349	434
TK..98/TRF58	MY63..	132	396	451	185	240
	MY71D	145	410	474	199	263
	MY80..	145	460	524	249	313
	MY90..	197	480	565	269	354
	MY100M	197	530	615	319	404
	MY100L	197	560	645	349	434
TK..108/TRF78	MY112M	221	565	645	354	434
	MY63..	132	426	481	179	234
	MY71D	145	440	504	193	257
	MY80..	145	490	554	243	307
	MY90..	197	508	593	261	346
	MY100M	197	558	643	311	396
	MY100L	197	588	673	341	426
	MY112M	221	592	672	345	425
	MY132S	221	637	717	390	470
	MY132M	275	659	771	412	524
	MY132ML	275	719	831	472	584
	MY160M	275	719	831	472	584

TK../TRF..	MY..	AC	L	L1	B	B1
TK..128/TRF78	MY63..	132	411	466	179	234
	MY71D	145	425	489	193	257
	MY80..	145	475	539	243	307
	MY90..	197	493	578	261	346
	MY100M	197	543	628	311	396
	MY100L	197	573	658	341	426
	MY112M	221	577	657	345	425
	MY132S	221	622	702	390	470
	MY132M	275	644	756	412	524
	MY132ML	275	704	816	472	584
	MY160M	275	704	816	472	584
	TK..128/TRF88	MY90..	197	537	622	257
MY100M		197	587	672	307	392
MY100L		197	617	702	337	422
MY112M		221	620	700	340	420
MY132S		221	665	745	385	465
MY132M		275	687	799	407	519
MY132ML		275	747	859	467	579
MY160M		275	747	859	467	579
MY160L		331	794	950	514	670
MY180..		331	866	1022	586	742
MY80..		145	556	620	231	295
TK..168/TRF98 TKH168B/TRF98 TKH188B/TRF98 TKH188B/TRF98		MY90..	197	576	661	251
	MY100M	197	626	711	301	386
	MY100L	197	656	741	331	416
	MY112M	221	660	740	335	415
	MY132S	221	705	785	380	460
	MY132M	275	727	839	402	514
	MY132ML	275	787	899	462	574
	MY160M	275	787	899	462	574
	MY160L	331	834	990	509	665
	MY180..	331	906	1062	581	737
	MY200..	394	954	1110	629	785
	TK..168/TRF108 TK168/TRF108 TKH168B/TRF108 TK188/TR1F08 TKH188B/TRF108	MY100M	197	677	762	295
MY100L		197	707	792	325	410
MY112M		221	711	791	329	409
MY132S		221	756	836	374	454
MY132M		275	778	890	396	508
MY132ML		275	838	950	456	568
MY160M		275	838	950	456	568
MY160L		331	885	1041	503	659
MY180..		331	957	1113	575	731
MY200..		394	1005	1161	623	779
MY225..		394	1087	1243	705	861

7.3 TK..AM(IEC).. Outline Dimension

**TK..AM(IEC)..**

Flange.1

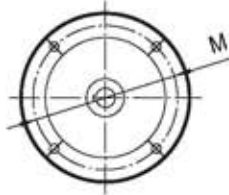

Flange.2

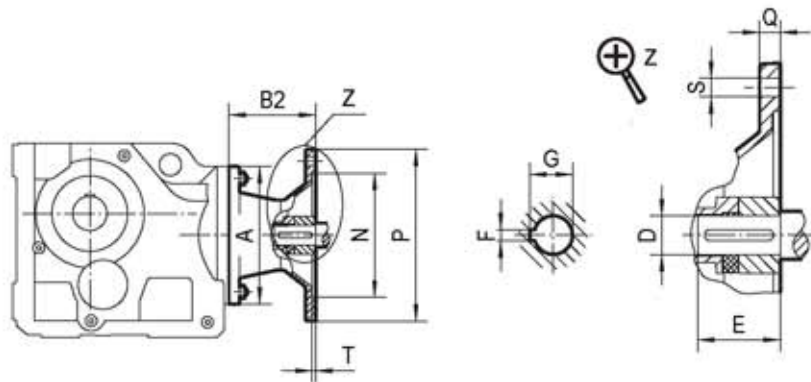
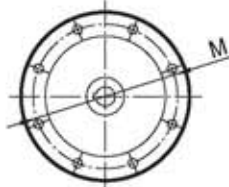

TK..	AM..	Flange.	A	B2	D	E	F	G	M	N	P	Q	S	T
TK..38	AM63	1	120	72	11	23	4	12.8	115	95	140	10	4-Φ9	3.5
	AM71 <sup>1)</sup>				14	30	5	16.3	130	110	160			
	AM80 <sup>1)</sup>			106	19	40	6	21.8	165	130	200	12	4-Φ11	4.5
	AM90 <sup>1)</sup>				24	50	8	27.3						
Tk..48 <sup>2)</sup> Tk..58 TK..68	AM63	1	160	66	11	23	4	12.8	115	95	140	10	4-Φ9	3.5
	AM71				14	30	5	16.3	130	110	160			
	AM80			99	19	40	6	21.8	165	130	200	12	4-Φ11	4.5
	AM90				24	50	8	27.3						
	AM100 <sup>1)</sup>			134	28	60	8	31.3	215	180	250	15	4-Φ13.5	5
	AM112 <sup>1)</sup>													
	AM132S/M <sup>1)</sup>				191	38	80	10	41.3	265	230	300		
TK..78	AM63	1	200	60	11	23	4	12.8	115	95	140	10	4-Φ9	3.5
	AM71				14	30	5	16.3	130	110	160			
	AM80			92	19	40	6	21.8	165	130	200	12	4-Φ11	4.5
	AM90				24	50	8	27.3						
	AM100 <sup>1)</sup>			126	28	60	8	31.3	215	180	250	15	4-Φ13.5	5
	AM112 <sup>1)</sup>													
	AM132S/M <sup>1)</sup>				179	38	80	10	41.3	265	230	300		
	TK..88			AM80	1	250	87	19	40	6	21.8	165	130	200
AM90		24	50	8				27.3						
AM100		121	28	60			8	31.3	215	180	250	15	4-Φ13.5	5
AM112														
AM132S/M			174	38			80	10	41.3	265	230	300		
AM132ML		232	42	110			12	45.3	300	250	350	18	4-Φ17.5	6
AM160 <sup>1)</sup>			48				14	51.8						
AM180 <sup>1)</sup>														

1) Dimension P/2 may protrude past foot mounting surface, please check.

2) not with AM112.



**TK..AM(IEC)..**

Flange.1

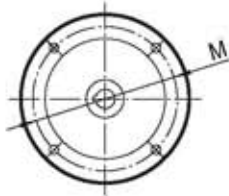

Flange.2

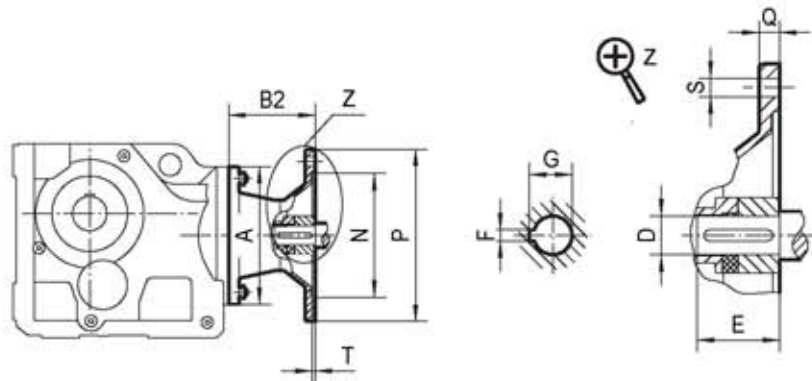
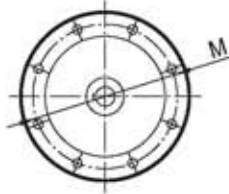

TK..	AM..	Flange.	A	B2	D	E	F	G	M	N	P	Q	S	T	
TK..98	AM100	1	300	116	28	60	8	31.3	215	180	250	15	4-Φ13.5	5	
	AM112														
	AM132S/M														
	AM132ML			110	42	80	10	41.3	265	230	300	16			
	AM160														
	AM180														
	AM200														
TK..108	AM100	1	350	110	28	60	8	31.3	215	180	250	15	4-Φ13.5	5	
	AM112														
	AM132S/M														
	AM132ML			110	42	80	10	41.3	265	230	300	16			
	AM160														
	AM180														
	AM200														
	AM225			2	140	18	64.4	400	350	450	22	8-Φ17.5			7
TK..128	AM132S/M	1	450	148	38	80	10	41.3	265	230	300	16	4-Φ13.5	5	
	AM132ML														
	AM160														
	AM180			110	206	42	80	10	45.3	300	250	350			18
	AM200														
	AM225														
	AM250														
AM280	2	140	18	69.4	500	450	550	25	8-Φ17.5	7					
TK..158 TK..168 TK..188	AM160	1	550	198	42	110	12	45.3	300	250	350	18	4-Φ17.5	6	
	AM180														
	AM200														
	AM225			140	254	60	18	64.4	400	350	450	22			
	AM250														
	AM280														
AM250	2	140	20	79.9	500	450	550	25	8-Φ17.5	7					

**7.4 TK..AD.. Outline Dimension**

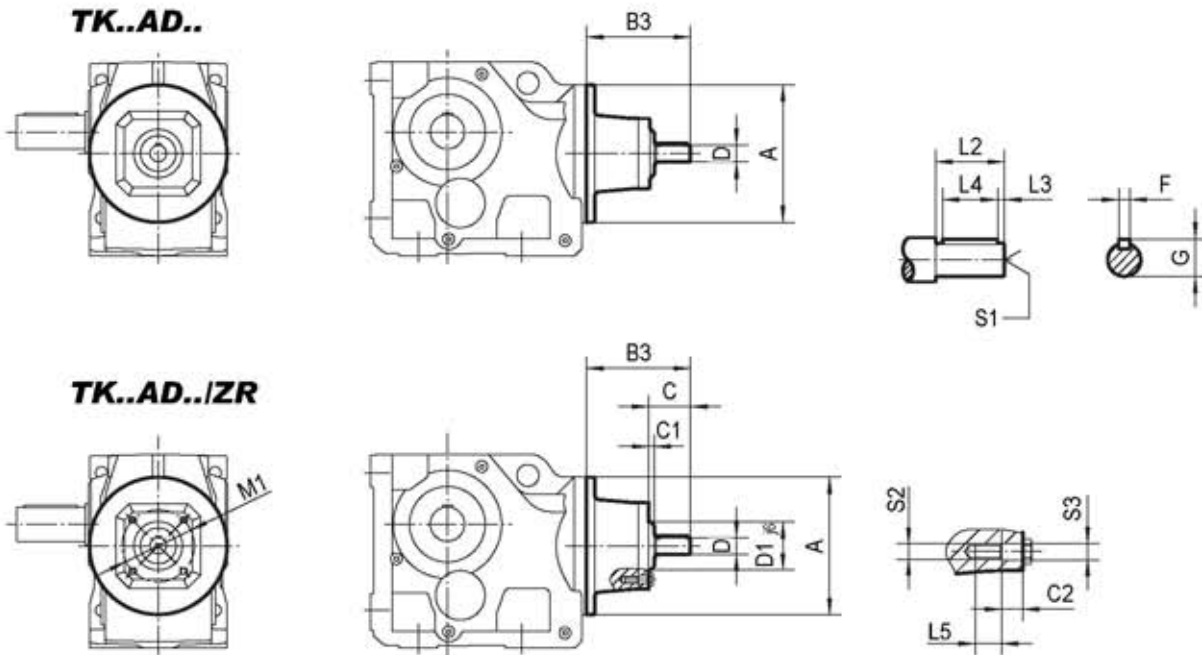

TK..	AD..	A	B3	C	C1	C2	D	D1	F	G	L2	L3	L4	L5	M1	S1	S2	S3
TK..38	AD1	120	102	-	-	-	16	-	5	18	40	4	32	-	-	M5X12.5	-	-
	AD2,AD2/ZR		130	50	8	13.5	19	55	6	21.5	40	4	32	12	80	M6X16	M8	9
TK..48	AD2,AD2/ZR	160	123	50	8	13.5	19	55	6	21.5	40	4	32	12	80	M6X16	M8	9
TK..58			AD3,AD3/ZR	159	60	8	15.5	24	70	8	27	50	5	40	16	105	M8X19	M10
TK..78	AD2,AD2/ZR	200		116	50	8	13.5	19	55	6	21.5	40	4	32	12	80	M6X16	M8
	AD3,AD3/ZR		151	60	8	15.5	24	70	8	27	50	5	40	16	105	M8X19	M10	11
	AD4,AD4/ZR		224	95.5	13	16	38	100	10	41	80	5	70	20	130	M12X28	M12	13.5
TK..88	AD2,AD2/ZR	250	111	50	8	13.5	19	55	6	21.5	40	4	32	12	80	M6X16	M8	9
	AD3,AD3/ZR		156	70	8	15.5	28	70	8	31	60	5	50	16	105	M8X19	M10	11
	AD4,AD4/ZR		219	95.5	13	16	38	100	10	41	80	5	70	20	130	M12X28	M12	13.5
	AD5, AD5/ZR		292	126	11	24	42	120	12	45	110	10	70	20	180	M16X36	M12	13.5
TK..98	AD3,AD3/ZR	300	151	70	8	15.5	28	70	8	31	60	5	50	16	105	M8X19	M10	11
	AD4,AD4/ZR		214	95.5	13	16	38	100	10	41	80	5	70	20	130	M12X28	M12	13.5
	AD5,AD5/ZR		287	126	11	24	42	120	12	45	110	10	70	20	180	M16X36	M12	13.5
	AD6,AD6/ZR		327	130.5	11	22.5	48	130	14	51.5	110	10	80	26	200	M16X36	M16	17.5
TK..108	AD3,AD3/ZR	350	145	70	8	15.5	28	70	8	31	60	5	50	16	105	M8X19	M10	11
	AD4,AD4/ZR		208	95.5	13	16	38	100	10	41	80	5	70	20	130	M12X28	M12	13.5
	AD5,AD5/ZR		281	126	11	24	42	120	12	45	110	10	70	20	180	M16X36	M12	13.5
	AD6,AD6/ZR		321	130.5	11	22.5	48	130	14	51.5	110	10	80	26	200	M16X36	M16	17.5
TK..128	AD4,AD4/ZR	450	193	95.5	13	16	38	100	10	41	80	5	70	20	130	M12X28	M12	13.5
	AD5,AD5/ZR		266	126	11	24	42	120	12	45	110	10	70	20	180	M16X36	M12	13.5
	AD6,AD6/ZR		306	130.5	11	22.5	48	130	14	51.5	110	10	80	26	200	M16X36	M16	17.5
	AD7,AD7/ZR		300	133	13	19	55	125	16	59	110	10	90	30	190	M20X42	M20	22
	AD8,AD8/ZR		383	155	5	22.5	70	120	20	74.5	140	15	110	19.5	210	M20X42	M12	13.5
TK..158	AD5,AD5/ZR	550	258	126	11	24	42	120	12	45	110	10	70	20	180	M16X36	M12	13.5
TK..168	AD6,AD6/ZR		298	130.5	11	22.5	48	130	14	51.5	110	10	80	26	200	M16X36	M16	17.5
TK..188	AD7,AD7/ZR		292	133	13	19	55	125	16	59	110	10	90	30	190	M20X42	M20	22
	AD8,AD8/ZR		374	155	5	22.5	70	120	20	74.5	140	15	110	19.5	210	M20X42	M12	13.5

## 8. MOUNTING POSITIONS

### 8.1 Mounting position designation

Differentiates between six mounting positions M1 ... M6 for gear units. The following figure shows the spatial orientation of the gearmotor in mounting positions M1 ... M6.

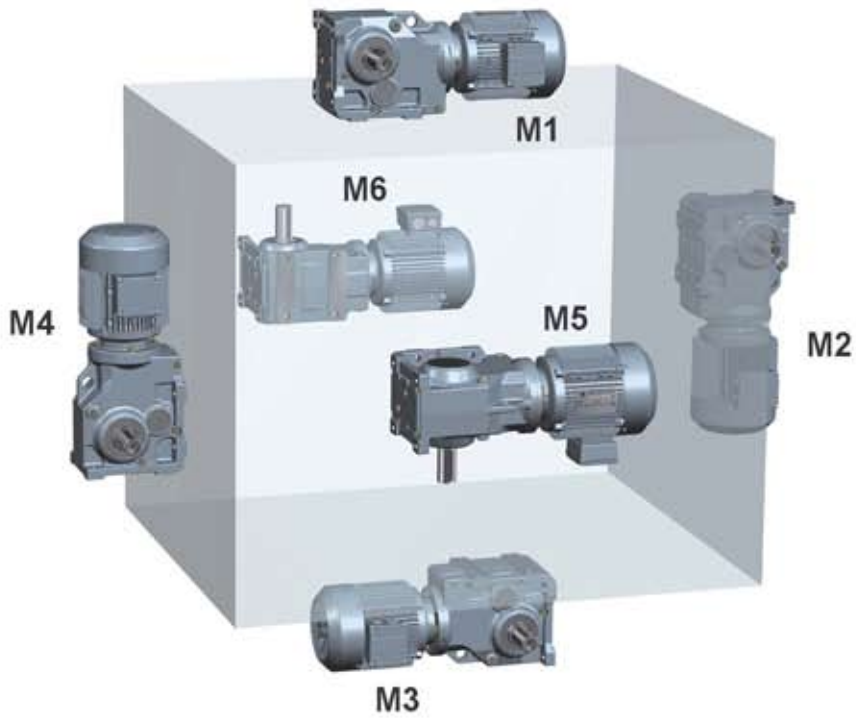

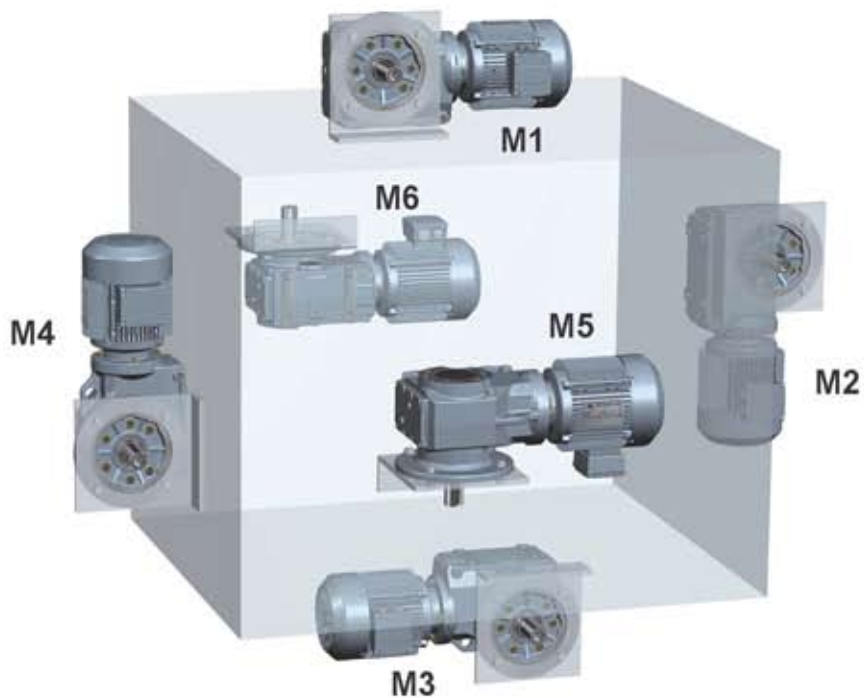

**TK..**





8.2. Mounting positions for helical-bevel gearmotors

**TK/TKA..B/TKH38B-158B,TKV38B-108B**

Symbol	Meaning
	Breather valve
	Oil level plug
	Oil drain plug

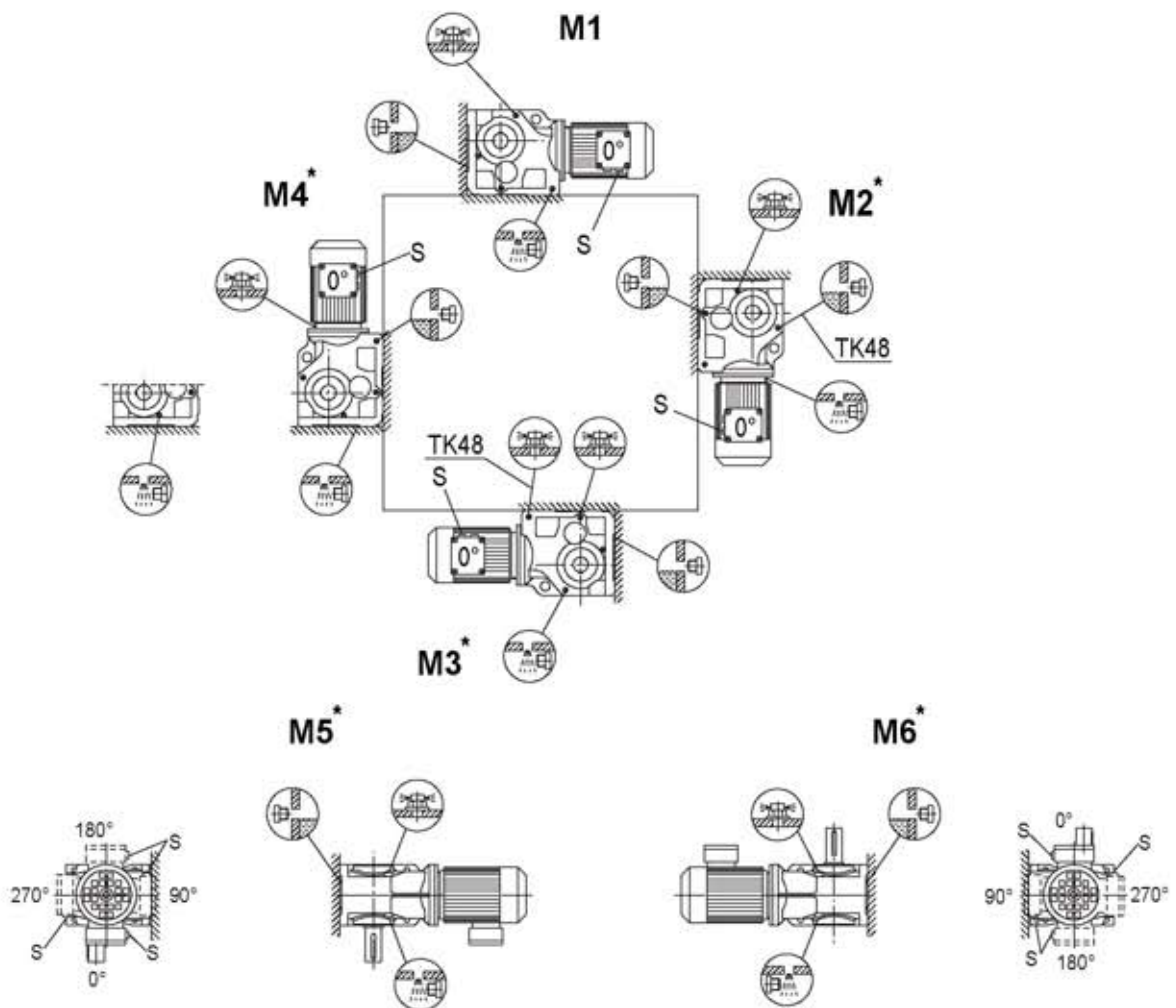
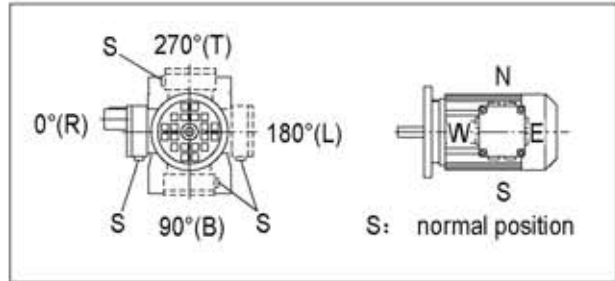



Mounting position	Gear unit size	Input speed [r/min]
M2*,M3*,M4*,M5*,M6*	78...108	>2500
	>108	>1500

Important: Please refer to the **i** information in the 'Geared Motors' catalog, Sec(page 142).

Increased churning losses may arise in some mounting positions. Contact us in case of the above-mentioned combinations.

**TK168-188,TKH168B-188B**

Symbol	Meaning
	Breather valve
	Oil level plug
	Oil drain plug

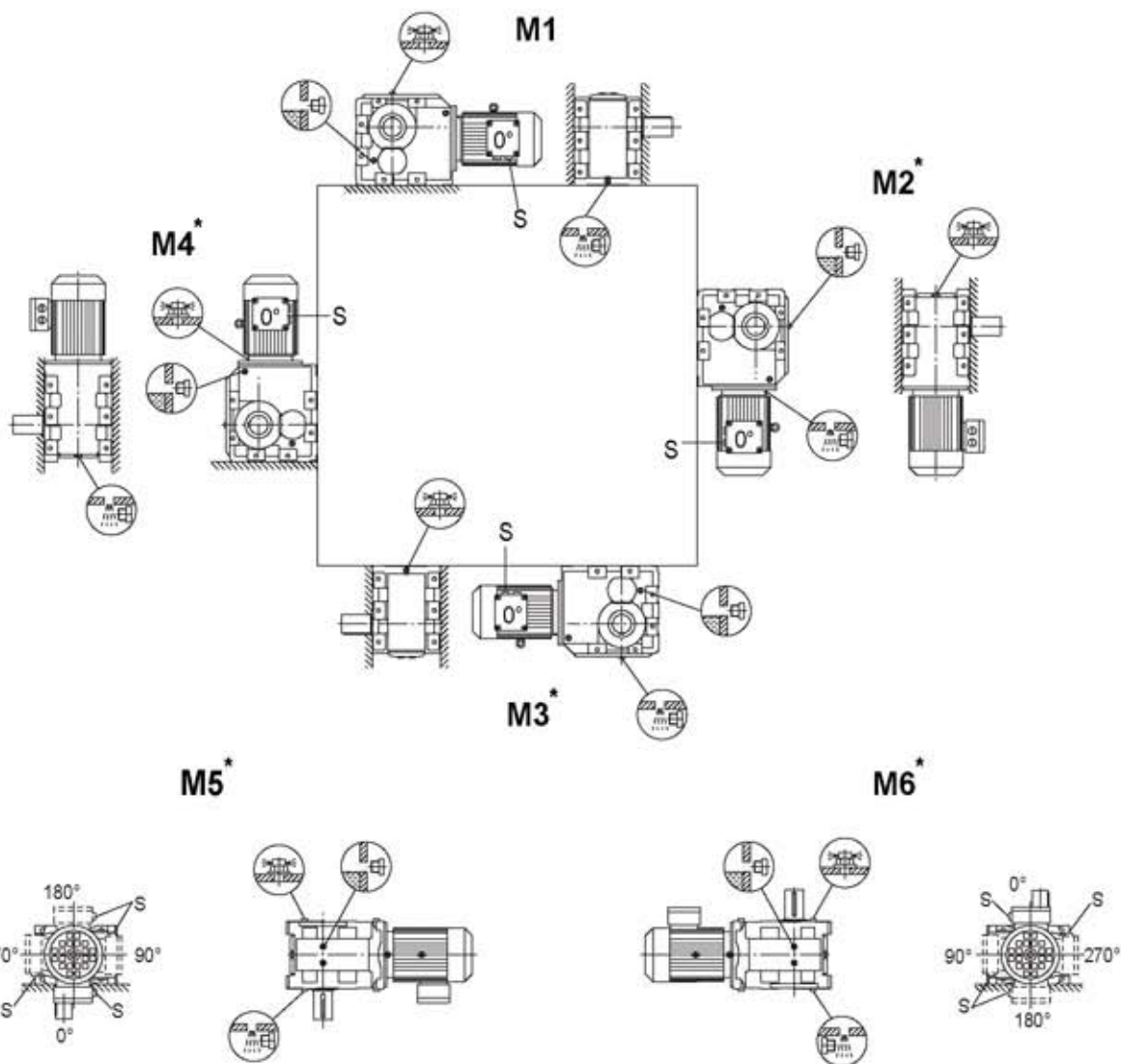
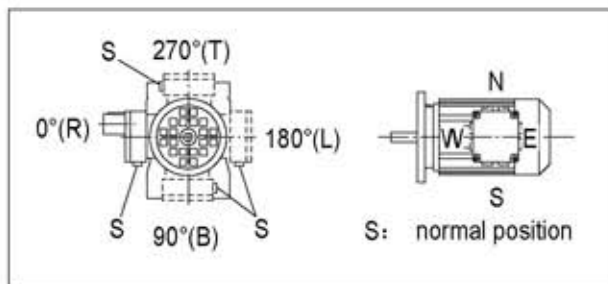



Mounting position	Gear unit size	Input speed [r/min]
M2*,M3*,M4*,M5*,M6*	78...108	>2500
	>108	>1500

Important: Please refer to the **i** information in the 'Geared Motors' catalog, Sec(page 142).

Increased churning losses may arise in some mounting positions. Contact us in case of the above-mentioned combinations.

**TKF/TKAF/TKHF/TKAZ/TKHZ38-158,TKVF/TKVZ38-108**

Symbol	Meaning
	Breather valve
	Oil level plug
	Oil drain plug

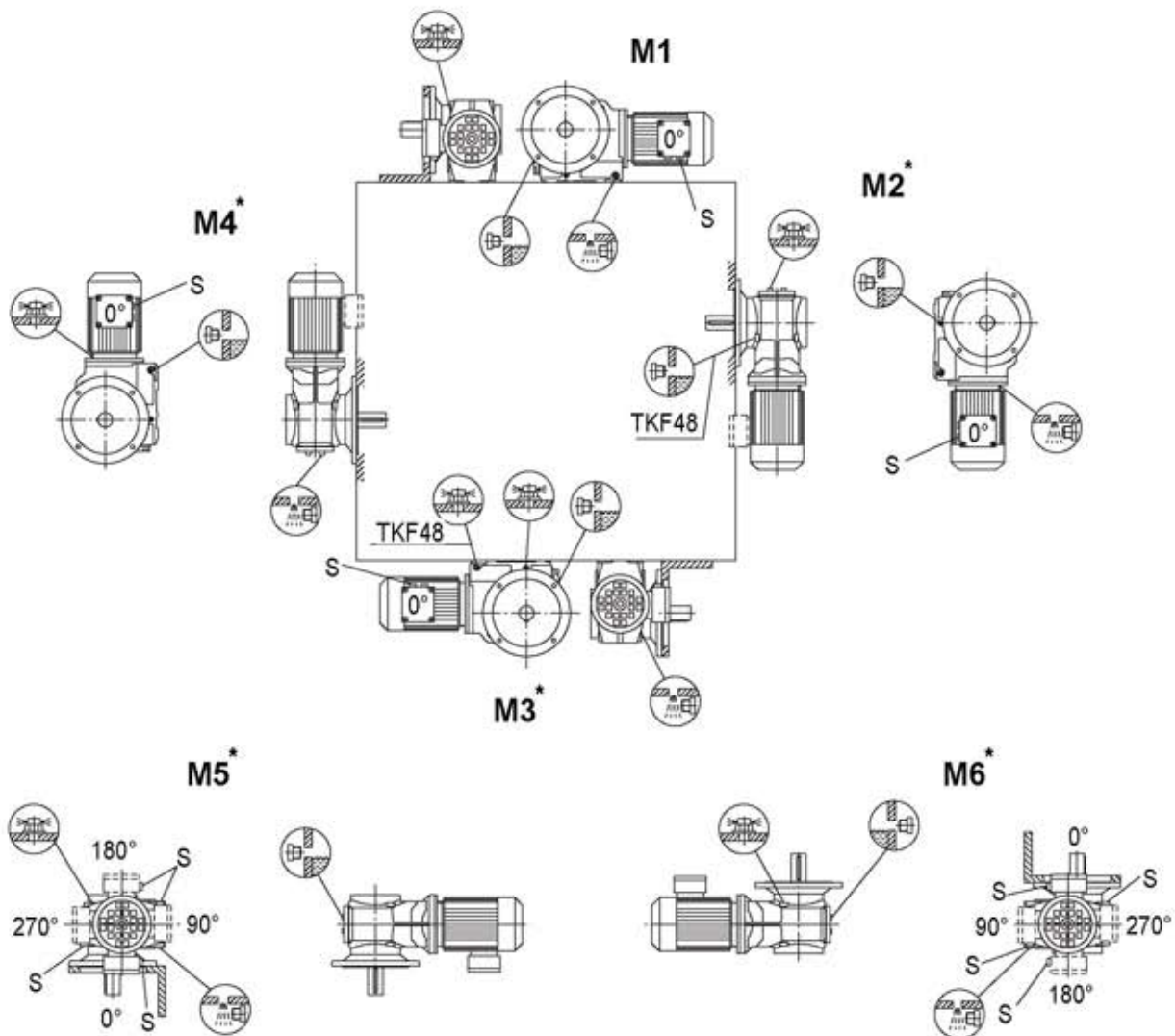
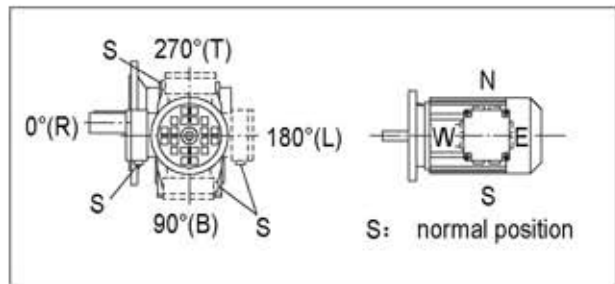



Mounting position	Gear unit size	Input speed [r/min]
M2*,M3*,M4*,M5*,M6*	78...108	>2500
	>108	>1500

Increased churning losses may arise in some mounting positions. Contact us in case of the above-mentioned combinations.



**TKA/TKH38-158,TKV38-108**

Symbol	Meaning
	Breather valve
	Oil level plug
	Oil drain plug

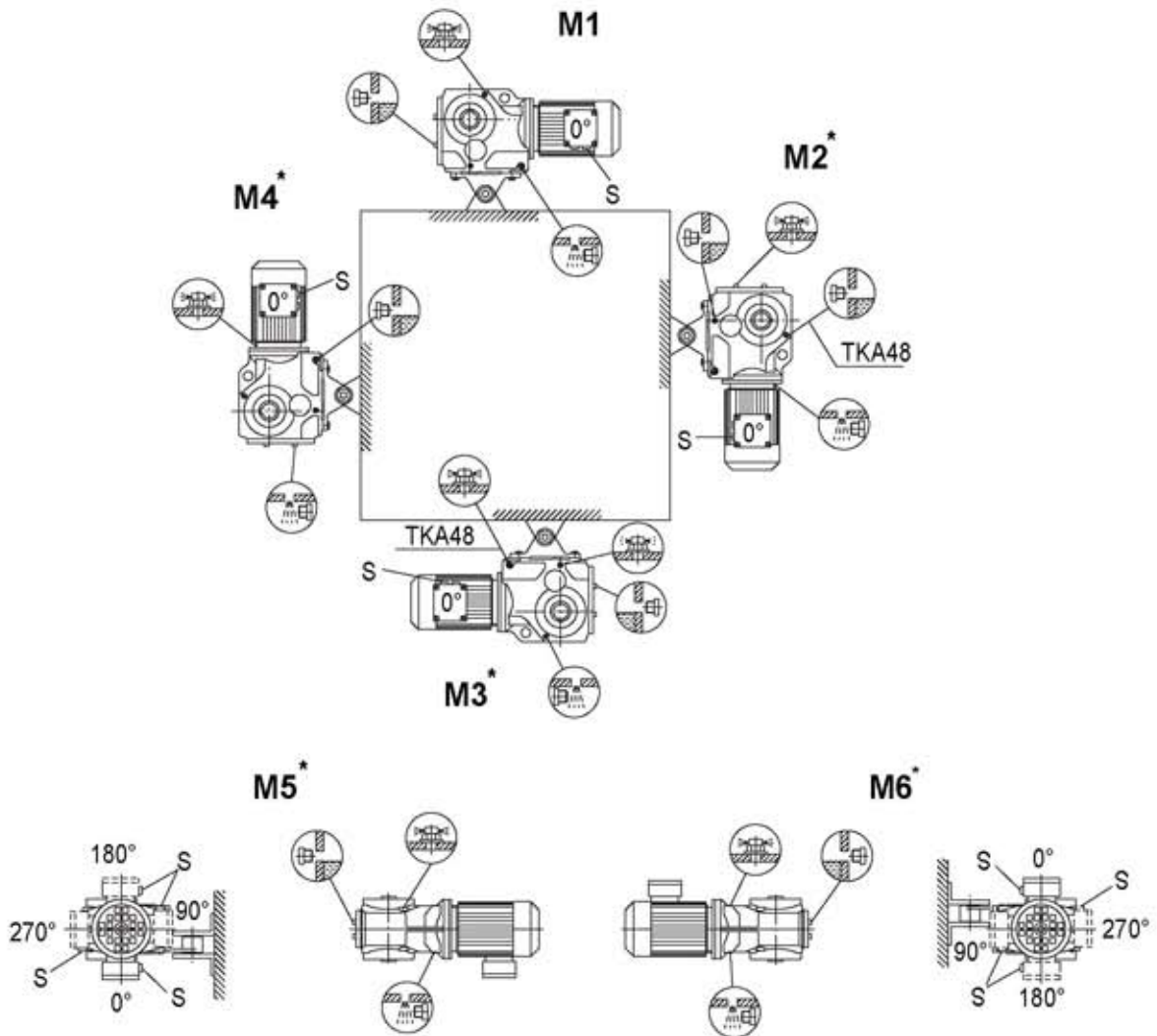
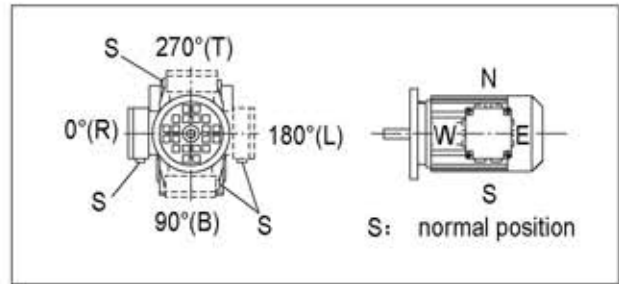

Mounting position	Gear unit size	Input speed [r/min]
M2*,M3*,M4*,M5*,M6*	78...108	>2500
	>108	>1500

Increased churning losses may arise in some mounting positions. Contact us in case of the above-mentioned combinations.

**TKH168-188**

Symbol	Meaning
	Breather valve
	Oil level plug
	Oil drain plug

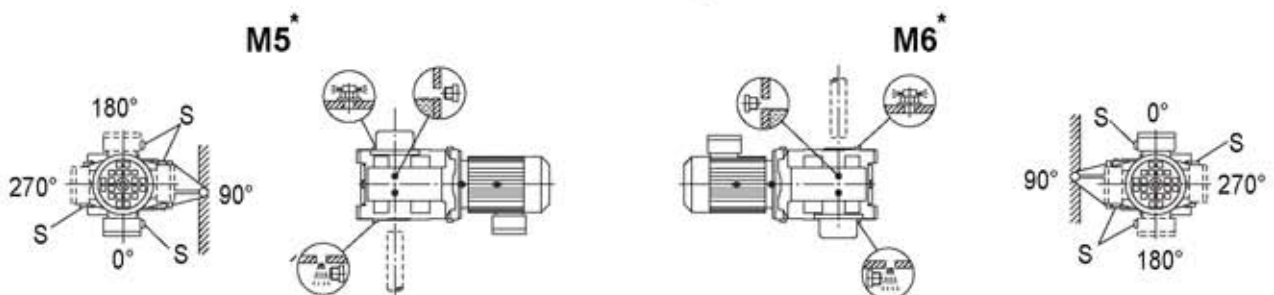
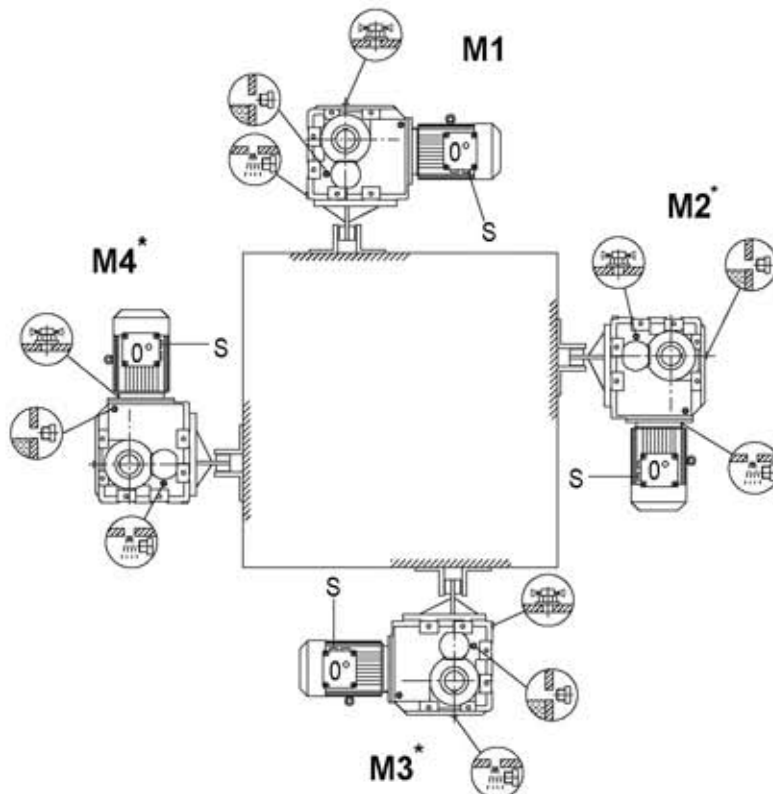
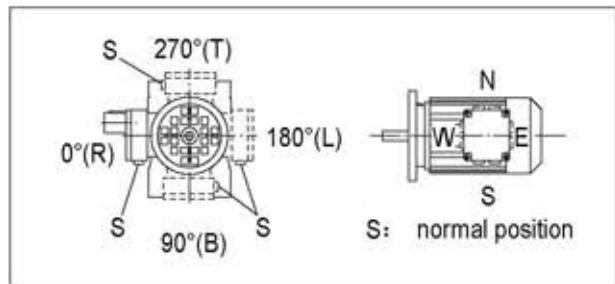

Mounting position	Gear unit size	Input speed [r/min]
M2*,M3*,M4*,M5*,M6*	78...108	>2500
	>108	>1500

Increased churning losses may arise in some mounting positions. Contact us in case of the above-mentioned combinations.



The data refer to the radial force acting midway on the shaft end (with right-angle gear units on the A-side output). Worst case conditions have been assumed for the force application angle  $\alpha$  and the direction of rotation.

1. only 50% of the  $F_{r2}$  value specified in the selection tables is permitted in mounting position  $M_1$  with wall attachment on the front face for TK gear units
2. Helical-bevel geared motors TK168 and TK188 in mounting positions  $M_1$  to  $M_4$ : A maximum of 50% of the overhung load  $F_{r2}$  specified in the selection tables in the case of gear unit mounting other than as shown in the mounting position sheets.

### 8.3 Direction of rotation

If the drive has a backstop RS, it is also necessary to stipulate the direction of rotation of the drive. The following definition applies, looking onto the output shaft:

Clockwise(CW)=Rotating clockwise

Counterclockwise(CW)=Rotating clockwise

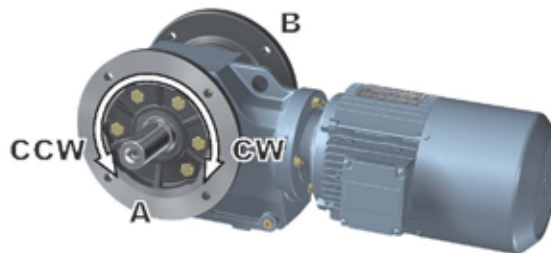

Figure :Direction of rotation of the output.

In right-angle gear units it is also necessary to stipulate whether the direction of rotation is given looking onto the A or B end.

### 8.4 Position of the output shaft and the output flange

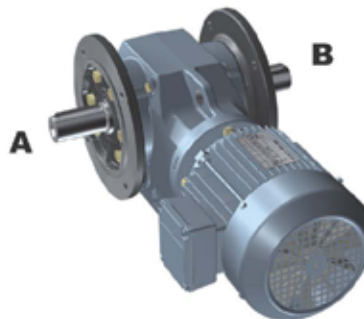

Figure:Position of the output shaft and the output flange

In right-angle gear units, it is also necessary to stipulate the position of the output shaft and the output flange:

A or B or A+B



### 8.5 Position of the connection end in right-angle gear units

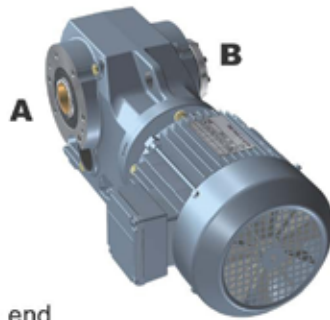

Figure: Position of the connection end

In shaft mounted right-angle gear unit with a shrink disk, it is also necessary to stipulate whether the **A** or **B** end is the connection end. In Figure 12, the **A** end is the connection end, the shrink disk is located opposite to the connection end.

Only connection end at bottom is possible with helical-bevel gear units TK168/TK188 in mounting positions M5 and M6.

### 8.6 Sample orders

TYPE (examples)	Mounting position	Shaft with	Flange with	Connection end	Position of shrink disk	Position of terminal box	Position	Direction of rotation of the output
TK48MY71D4/RS	M2	A	-	-	-	0°	'S'	CW
TKA98MY132M4	M4	-	-	B	-	270°	'E'	-
TKH108MY160L4	M1	-	-	A	B	180°	'N'	-

## 9. INSTALLATION METHODS

### 9.1. Preparation before the installation:





- Check if the data on the nameplates of the gearmotor matches the voltage supply system.
- Check if the drive has not been damaged during transportation and storage.
- For standard gear unit, the ambient temperature must be in accordance with the corresponding lubricant table.
- The drive must not be assembled in conditions such as oil, gas, vapors, acids, radiation and so on.
- Output shaft and flange surfaces must thoroughly cleaned to ensure they are free of anti-corrosion agents, contamination or similar. Use a commercially available solvent. Do not let the solvent come into contact with the sealing lip of the oil seals, or will damage the material!
- The supporting structure must have the following characteristics: level, vibration damping and torsionally rigid.
- So as to prevent the tolerance of fit of gear units from damaging, the parts assembled on the gear units must be worked as specified tolerance according to **ISOH7**.

### 9.2. the installation of the gear units:

- Do not tighten the housing legs and mounting flanges against one another and ensure that you comply with the permitted radial load and axial load.
- Never drive belt pulleys, couplings, pinions, etc. onto the shaft end by hitting them with a hammer. This will damage the bearing, housing and the shaft.
- When installing the **IEC** couplings, remove the key from the motor shaft and replace it with the supplied key. Secure key and coupling half using grub screw and tighten to the motor shaft. Seal the contact surface between the adapter and motor using a suitable sealing compound.
- Prior to startup, check that if the oil level is as specified for the mounting position. if the oil checking and drain screw and the breather valves are free accessible.

## 10. LUBRICATION

### 10.1 Types of lubrication

						lubrication type
<b>TK..</b>	Standard -10      +40	VG 220	Shell Omala 220	Mobilgear 630	BP Energol GR-XP 220	Mineral oil
	-20      +25	VG 150 VG 100	Shell Omala 100	Mobilgear 627	BP Energol GR-XP 100	
	-30      +10	VG 68-46 VG 32	Shell Tellus T 32	Mobil D.T.E. 13M		
	-40      -20	VG 22 VG 15	Shell Tellus T 15	Mobil D.T.E. 11M	BP Energol HLP-HM 15	
	-40      +80	VG 220	Shell Omala HD 220	Mobil SHC 630		Synthetic oil
	-40      +40	VG 150		Mobil SHC 629		
-40      +10	VG 32		Mobil SHC 624			

### 10.2 Lubricant fill quantity

The specified fill quantities are recommended values. The precise values vary depending on the number of stages and gear ratio. When filling, it is essential to check the oil level plug since it indicates the precise oil capacity. The following tables show guide values for lubricant fill quantities in relation to the mounting position M1 ~ M6.

#### **TK..,TKA..B,TKH..B,TKV..B:**

Gear units	Fill quantity in liters (L)					
	M1	M2	M3	M4	M5	M6
TK..38	0.50	1.00	1.00	1.30	0.95	0.95
TK..48	0.80	1.30	1.50	2.0	1.60	1.60
TK..58	1.20	2.3	2.5	3.0	2.6	2.4
TK.68	1.10	2.4	2.6	3.4	2.6	2.6
TK..78	2.2	4.1	4.4	5.9	4.2	4.4
TK..88	3.7	8.0	8.7	10.9	8.0	8.0
TK..98	7.0	14.0	15.7	20.0	15.7	15.5
TK..108	10.0	21.0	25.5	33.5	24.0	24.0
TK..128	21.0	41.5	44.0	54	40.0	41.0
TK..158	31.0	62	62	90	58	62
TK..168	33.0	95	105	123	85	84
TK..188	53	152	167	200	143	143

**TKF...:**

Gear units	Fill quantity in liters (L)					
	M1	M2	M3	M4	M5	M6
TKF38	0.50	1.00	1.00	1.50	1.00	1.00
TKF48	0.80	1.30	1.70	2.2	1.60	1.60
TKF58	1.30	2.3	2.7	3.2	2.9	2.7
TKF68	1.10	2.4	2.8	3.6	2.7	2.7
TKF78	2.1	4.1	4.4	6.0	4.5	4.5
TKF88	3.7	8.2	9.0	11.9	8.4	8.4
TKF98	7.0	14.7	17.3	21.5	15.7	16.5
TKF108	10.0	22.0	26.0	35.0	25.0	25.0
TKF128	21.0	41.5	46.0	55	41.0	41.0
TKF158	31.0	66	69	92	62	62

**TKA..., TKH..., TKV..., TKAF..., TKHF..., TKVF..., TKAZ..., TKHZ..., TKVZ...:**

Gear units	Fill quantity in liters (L)					
	M1	M2	M3	M4	M5	M6
TK..38	0.50	1.00	1.00	1.40	1.00	1.00
TK..48	0.80	1.30	1.60	2.1	1.60	1.60
TK..58	1.30	2.3	2.7	3.2	2.9	2.7
TK..68	1.10	2.4	2.7	3.6	2.6	2.6
TK..78	2.1	4.1	4.6	6.0	4.4	4.4
TK..88	3.7	8.2	8.8	11.1	8.0	8.0
TK..98	7.0	14.7	15.7	20.0	15.7	15.7
TK..108	10.0	20.5	24.0	32.0	24.0	24.0
TK..128	21.0	41.5	43.0	52	40.0	40.0
TK..158	31.0	66	67	87	62	62
TK..168	33.0	95	105	123	85	84
TK..188	53	152	167	200	143	143

**11. MAINTENANCE**

1). For gear units, first oil change should be after about 300 hours (run-in period). The right lotion is required to clean the gear units with care. Never mix the synthetic oil and mineral oil together.

2). Every 3000 working time, at least every 6 months, you have to check the oil and oil level, the seals visually for leakage. For IEC input gear units, the elastomer should be tested or replaced if necessary.

3). Depending on the operating conditions (see chart below), every 3 years at the latest for inspection is needed. Then change the mineral oil and replace the bearing grease.

4). Depending on the operating conditions, change the oil seals on output shaft.

5). Once the malfunctions appear, stop disassembling the parts, and firstly please contact the customer service (the information about specification, delivery date, series number, time used, name of machine, machine manufacturer, malfunction problems is required) , then take the reasonable measures.



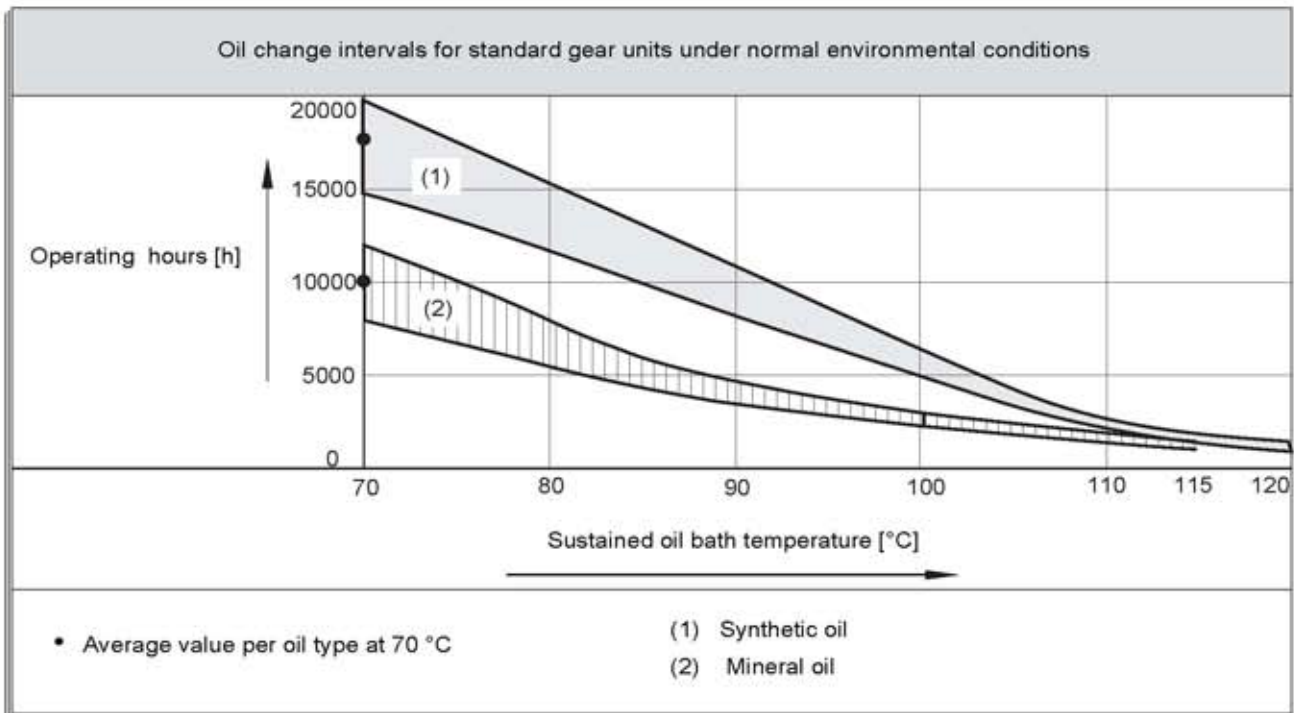

## 12. STORAGE

- 1). Under roof, protected against rain and snow, no shock loads.
- 2). Underlay the block and other material between the ground and equipment.
- 3). The opened but not used gear units should be added with the anti-corrosive oil on its surface, and then return to the packing containers timely.
- 4). Two years or more given regular inspections. Check for cleanliness and mechanical damage as part of the inspection, Check corrosion protection.

## 13. NOTICE FOR ORDER

Please offer the following information when place the orders:

- 1). the model mark of the gear units (type, ratio, power and mounting position).
- 2). gear units are available with "blue/gray" painting optionally. Unless specified, it offers the blue painting as standard.
- 3). quantity ordered.
- 4). other special requirements.
- 5). company, contact and telephone.

## 14. MALFUNCTIONS

### 14.1 Gear unit malfunctions

Problem	Possible cause	Remedy
Unusual, regular running noise	A. Meshing/grinding noise: Bearing damage. B. Knocking noise: Irregularity in the gearing	A. Check the oil, change bearings B. Contact customer service
Unusual, irregular running noise	Foreign bodies in the oil	<ul style="list-style-type: none"> <li>• Check the oil</li> <li>• Stop the drive, contact customer service</li> </ul>
Oil leaking <sup>1)</sup> <ul style="list-style-type: none"> <li>• From the gear cover plate</li> <li>• From the motor flange</li> <li>• From the motor oil seal</li> <li>• From the gear unit flange</li> <li>• From the output end oil seal</li> </ul>	A. Rubber seal on the gear cover plate leaking B. Seal defective C. Gear unit not vented	A. Tighten the bolts on the gear cover plate and observe the gear unit. Oil still leaking: Contact customer service B. Contact customer service C. Vent the gear unit (see "Mounting Positions")
Oil leaking from breaking valve	A. Too much oil B. Drive operated in incorrect mounting position C. Frequent cold starts (oil foams) and/or high oil level	A. Correct the oil level (see Sec. "Inspection and Maintenance") B. Mount the breather valve correctly (see Sec. "Mounting Positions") and correct the oil level (see "Lubricants")
Output shaft does not turn although the motor is running or the input shaft is rotated	Connection between shaft and hub in gear unit interrupted	Send in the gear unit/gearmotor for repair

1) Short-term oil/grease leakage at the oil seal is possible in the run-in phase (24 hours running time).

### 14.2 IEC couplings malfunctions

Problem	Possible cause	Remedy
Unusual, regular running noise	Meshing/grinding noise: Bearing damage	Contact our company customer service
Oil leaking	Seal defective	Contact our company customer service
Output shaft does not turn although the motor is running or the input shaft is rotated	Connection between shaft and hub in gear unit interrupted	Send the gear unit to our company for repair.
Change in running noise and / or vibrations occur	A. Annular gear wear, short-term torque transfer through metal contact B. Bolts to secure hub axially are loose.	A. Change the annular gear B. Tighten the bolts
Premature wear in annular gear	A. Contact with aggressive fluids / oil; ozone influence; too high ambient temperatures etc, which can cause a change in the physical properties of the annular gear. B. Impermissibly high ambient/contact temperature for the annular gear; maximum permitted temperature -20 °C to +80 °C. C. Overload	Contact our company customer service

**15. Charge Characteristic Chart (for reference)**

AIR BLOWERS		Hoist gear assembly	A
Air blower(axial or radial)	A	Derrick gear assembly	B
Fan of cooling tower	B	Steering gear assembly	B
Induced draught fan	B	Moving gear assembly	C
Rotary piston type fan	B	LAND DREDGER	
Turbo-fan	A	Drum-type coveyer	C
CONSTRUCTION MACHINERY		Drum-type rotation wheel	C
Concrete mixer	B	Dredger head	C
Hoist	B	Powered crab	B
Road building machinery	B	Pump	B
Boring mill	B	Pump turning gear assembly	B
CHEMICAL MACHINERY		Moving gear assembly (apron wheel)	C
Mixer (liquid)	A	Moving gear assembly (track)	B
Mixer (half liquid)	B	FOODSTUFF PROCESSING MACHINERY	
Centrifuge (heavy)	B	Placer or box filler	A
Centrifuge(light)	A	Cane crusher	A
** Cooling rolling drum	B	** Cane cutter	B
** Dry rolling drum	B	** Cane crasher	C
Mixer	B	Mixer	B
COMPRESSOR		Paste bucket	B
Piston type compressor	C	Packager	A
Turbo-compressor	B	Beet slicer	B
TRANSMISSION FREIGHTER		Beet washing machine	B
Pan conveyer	B	MOTOR AND CONVERSION EQUIPMENTS	
Balance lifter	B	Frequency converter	C
Trough conveyer	B	Motor	C
Ribbon conveyer (large piece)	C	Welding motor	C
Ribbon coveyer (small piece)	B	WASHING MACHINE	
Drum-type flour conveyer	A	Rolling drum	B
Chain conveyer	B	Washing machine	B
Ring type conveyer	B	METAL ROLLER MACHINE	
Lifter	B	** Steel cutter	C
Hoist	B	** Chain conveyer	B
Crank-connecting conveyer	B	** Cold mill	C
Lifter	B	Continuous casting equipments	B
Worm conveyer	B	** Cold bed	B
Steel-band conveyer	B	** Cropper	C
Chain reed-type conveyer	B	** Cross steering transmitter	B
Crab freighter	B	** Deruster	C
HOIST		** Heavy and medium steel mill	C
Bracket swing gear assembly	B	** Bar mill	C



BAR TRANSMISSION EQUIPMENTS	B	PUMPS	
Bar pusher	B	Centrifugal pump (thin liquid)	A
Push bed	B	Centrifugal pump (half liquid)	B
** Shears	C	Displacement pump	C
** Lumber elevator platform	B	Plunger pump	C
ROLL ADJUSTING EQUIPMENTS	B	Force pump	C
Roller leveling machine	B	PLASTIC EQUIPMENTS	
** Mill rolling way (heavy)	C	** Glazing press	B
** Mill rolling way (light)	B	** Ejecting press	B
** Sheet rolling mill	C	** Spiral extruding machine	B
** Trimming shears	B	** Mixing machine	B
Pipe welder	C	RUBBER EQUIPMENT	
Soldering machine(belt material and wire rod)	B	** Glazing press	B
Wire drawbench	B	** Ejecting press	C
METAL PROCESSING MACHINE TOOLS		** Mixing stir machine	B
Power shaft	A	Kneading machine	B
** Forging machine	C	** Roller machine	C
Drop hammer	C	STONE PORCELAIN CLAY PROCESSING EQUIPMENTS	
Machine tool and necessary	A		
Machine tool and main driving equipment	B	Ball crusher	B
Metal facing machine	C	** Ejecting press and breaker	C
Plate-leveling machine tool	C	Breaker	C
Backing-out punch	C	Brick press	C
Press machine tool	C	** Beating crusher	C
Cutting machine	B	** Converter	C
Sheet bending machine tool	B	** Cylinder mill	C
PETROLEUM PROCESSING MACHINERY		TEXTILE MACHINERY	
** Pump of oil pipe line	B	Feeding machine	B
Rotary drilling equipment	C	Loom machine	B
PAPERING MACHINE		Dyeing machine	B
** Glazing press	C	Purified drum	B
** Multilayer paper board machine	C	Welon machine	B
** Drying cylinder	C	WASTER TREATMENT EQUIPMENTS	
** Glazing cylinder	C	** Air blast	B
** Masher	C	Screw pump	B
** Mashing and breaking machine	C	WOOD PROCESSING MACHINE TOOL	
** Suction roll	C	Barker	C
** Wet paper roller machine	C	Facing machine	B
** Water absorbing roller machine	C	Saw bench	C
Welon machine	C	Wood processing machine tool	A

Note: A - Uniform load; B - Moderate shock load; C - Heavy shock load; \*\* - for 24hour system.

SHOW THE SERIES PRODUCTS

---

**TR** Series helical geared motors



**TS** Series helical-worm geared motors

**TK** Series helical-bevel geared motors



**TF** Series parallel shaft helical geared motors

**G3** Series mini helical geared motors



**TRC** Series mini helical gear units



**MHR** Series worm gear units

**UVL** Series stepless speed variator



