

**FDI Type** ◀ Standard Product

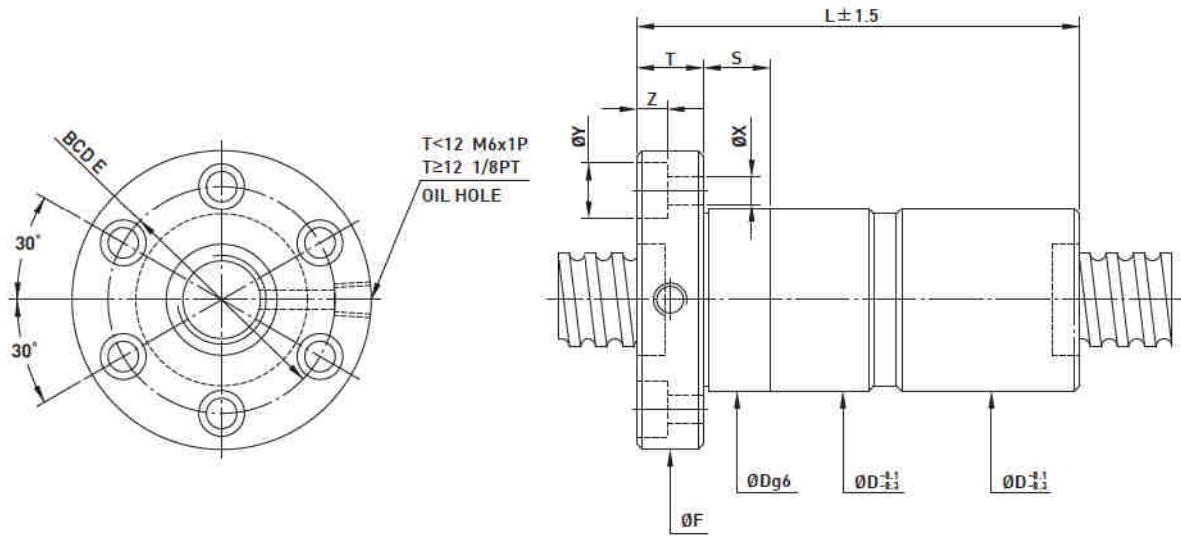

Model	Size		Ball Dia.	PCD	RD	Circuits	Stiffness K (kgf/µm)	Dynamic Load 1x10 <sup>4</sup> revs C (kgf)	Static Load Co (kgf)	Nut			Flange			Bolt			Fit			
	Nominal Dia.	Lead								D	L	F	T	BCD-E	X	Y	Z	S				
16-5T3	16	5	3.175	16.6	13.324	3	20	731	1331	28	30	78	54	12	41	5.5	9.5	5.5	24			
16-5T4				16.6	13.324	4	23	936	1775	28	30	90	54	12	41	5.5	9.5	5.5	24			
20-5T3				20	6	3.969	20.6	17.324	3	39	852	1767	32	34	78	57	12	45	5.5	9.5	5.5	24
20-5T4							20.6	17.324	4	54	1091	2356	32	34	92	57	12	45	5.5	9.5	5.5	24
20-6T3	20.8	16.744	3				39	1091	2081	34	36	89	60	12	48	5.5	9.5	5.5	24			
20-6T4	20.8	16.744	4				54	1398	2774	34	36	109	60	12	48	5.5	9.5	5.5	24			
25-2.5T5	25	2.5	2.000	25.2	23.136	5	66	716	2117	35	40	87	65	10	51	6.6	11	6.5	24			
25-5T3		5	3.175	25.6	22.324	3	55	977	2314	37	40	78	64	12	52	5.5	9.5	5.5	24			
25-5T4				20.6	22.324	4	73	1252	3085	37	40	96	64	12	52	5.5	9.5	5.5	24			
25-6T3				6	3.969	25.8	21.744	3	56	1272	2762	38	42	89	65	12	53	5.5	9.5	5.5	24	
25-6T4	25.8					21.744	4	75	1628	3682	38	42	109	65	12	53	5.5	9.5	5.5	24		
25-10T3	28	10	4.763	26	21.132	3	49	1643	3265	47	51	140	74	15	60	6.6	11	6.5	24			
28-5T5				5	3.175	28.6	25.324	5	86	1619	4404	45	50	110	74	12	62	5.5	9.5	5.5	24	
28-10T4						29	24.132	4	70	2199	4969	45	50	150	74	12	61	6.6	11	6.5	24	
32-2.5T6						2.5	2.000	32.2	30.136	6	97	928	3339	45	51	106	74	12	62	5.5	9.5	5.5
32-5T3	3	3.175	32.6					29.324	3	64	1117	3081	44	48	78	74	12	60	6.6	11	6.5	24
32-5T4			32.6	29.324	4			82	1431	4108	44	48	96	74	12	60	6.6	11	6.5	24		
32-5T6			32.6	29.324	6			121	2027	6162	44	48	118	74	12	60	6.6	11	6.5	24		
32-5.08T4			5.08	3.175	32.6	29.324	4	82	1430	4108	44	48	96	74	12	60	6.6	11	6.5	24		
32-6T3	3	3.969			32.8	28.744	3	65	1446	3620	45	50	89	76	12	62	6.6	11	6.5	24		
32-6T4					32.8	28.744	4	84	1852	4826	45	50	109	76	12	62	6.6	11	6.5	24		
32-6T6					32.8	28.744	6	125	2625	7239	45	50	137	76	12	62	6.6	11	6.5	24		
32-8T3			8	4.763	33	28.132	3	68	1810	4227	47	52	110	78	16	64	6.6	11	6.5	24		
32-8T4	33	28.132			4	82	2317	5635	47	52	136	78	16	64	6.6	11	6.5	24				
32-10T3	10	6.350			33.4	26.910	3	68	2539	5327	51	56	129	82	16	68	6.6	11	6.5	24		
32-10T4					33.4	26.910	4	82	3252	7102	51	56	155	82	16	68	6.6	11	6.5	24		
40-5T4			5	3.175	40.6	37.324	4	99	1599	5280	51	54	96	80	16	66	6.6	11	6.5	24		
40-5T6					6	3.969	40.6	37.324	6	146	2265	7919	51	54	122	80	16	66	6.6	11	6.5	24
40-6T4	40.8	36.744					4	100	2136	6420	53	56	113	88	16	72	9	14	8.5	30		
40-6T6	40.8	36.744					6	148	3028	9630	53	56	141	88	16	72	9	14	8.5	30		
40-8T4	8	4.763	41	36.132			4	102	2728	7596	55	60	136	92	16	75	9	14	8.5	30		
40-8T6			41	36.132	6	150	3866	11394	55	60	178	92	16	75	9	14	8.5	30				
40-10T3			10	6.350	41.4	34.91	3	76	2959	7069	60	65	133	96	16	80	9	14	8.5	30		
40-10T4					41.4	34.91	4	101	3789	9426	60	65	155	96	16	80	9	14	8.5	30		
40-10T5	41.4	34.91			5	119	4590	11781	60	65	192	96	16	80	9	14	8.5	30				
40-12T3	12	6.350			41.4	34.91	3	73	2958	7069	58	60	160	96	18	80	9	14	8.5	30		
40-12T4			41.4	34.91	4	101	3789	9425	58	60	186	96	18	80	9	14	8.5	30				

Remark : Stiffness values listed above are derived from theoretical formula while preload is 10% of dynamic load rating.

**FDI Type** ◀ Standard Product

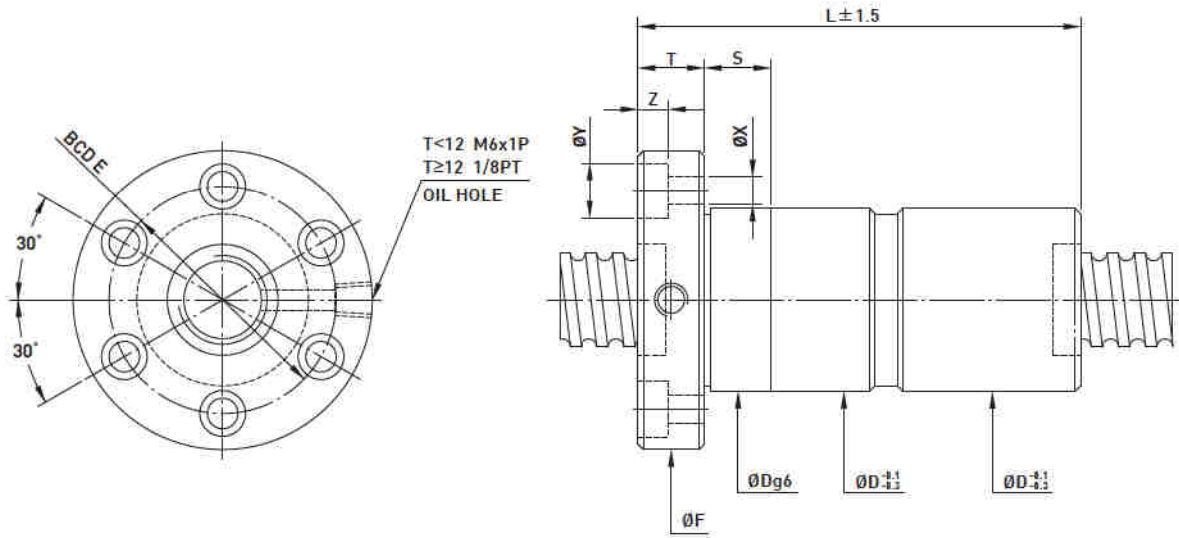

Model	Size		Ball Dia.	PCD	RD	Circuits	Stiffness K (kgf/µm)	Dynamic Load $1 \times 10^4$ revs C (kgf)	Static Load Co (kgf)	Nut		Flange			Bolt			Fit	
	Nominal Dia.	Lead								D	L	F	T	BCD-E	X	Y	Z		S
45-10T4	45	10	7.144	46.6	39.299	4	108	4683	11930	68	70	160	110	18	90	11	17.5	11	30
45-12T3		12	6.350	46.4	39.91	3	80	3115	7952	68	70	183	110	16	90	11	17.5	11	30
45-16T3		16	7.144	46.6	39.299	3	82	3656	8947	68	70	183	110	16	90	11	17.5	11	30
50-5T4	50	5	50.6	47.324	4	121	1757	6745	62	65	96	96	16	80	9	14	8.5	30	
50-5T6			50.6	47.324	6	177	2490	10117	62	65	122	96	16	80	9	14	8.5	30	
50-6T4		6	50.8	46.744	4	123	2388	8250	64	68	113	100	16	84	9	14	8.5	30	
50-6T6			50.8	46.744	6	179	3384	12375	64	68	147	100	16	84	9	14	8.5	30	
50-8T4		8	4.763	51	46.132	4	122	2998	9578	65	70	136	102	16	85	9	14	8.5	30
50-8T6				51	46.132	6	178	4249	14367	65	70	178	102	16	85	9	14	8.5	30
50-10T3	10	6.350	51.4	44.91	3	95	3397	9256	69	74	135	114	18	92	11	17.5	11	40	
50-10T4			51.4	44.91	4	124	4350	12341	69	74	157	114	18	92	11	17.5	11	40	
50-10T6			51.4	44.91	6	184	6165	18511	69	74	203	114	18	92	11	17.5	11	40	
50-12T3	12	7.938	51.8	43.688	3	94	4420	11047	73	78	158	118	18	96	11	17.5	11	40	
50-12T4			51.8	43.688	4	124	5660	14730	73	78	184	118	18	96	11	17.5	11	40	
63-6T4	63	6	63.8	59.744	4	148	2674	10542	78	80	115	119	18	98	11	17.5	11	40	
63-6T6			63.8	59.744	6	220	3704	15813	78	80	143	119	18	98	11	17.5	11	40	
63-8T4		8	4.763	64	59.132	4	152	3395	12541	79	82	138	122	18	100	11	17.5	11	40
63-8T6				64	59.132	6	222	4812	18811	79	82	180	122	18	100	11	17.5	11	40
63-10T4		10	6.350	64.4	57.91	4	158	4860	15858	82	88	159	134	20	110	14	20	13	40
63-10T6				64.4	57.91	6	228	6887	23786	82	88	205	134	20	110	14	20	13	40
63-12T4	12	7.938	64.8	56.688	4	152	6479	19293	86	92	186	138	20	114	14	20	13	40	
63-12T6			64.8	56.688	6	224	9182	28939	86	92	242	138	20	114	14	20	13	40	
80-10T4	80	10	81.4	74.91	4	190	5559	21118	99	105	172	152	20	127	14	20	13	40	
80-10T6			81.4	74.91	6	277	7879	31677	99	105	214	152	20	127	14	20	13	40	
80-12T4		12	7.938	81.8	73.688	4	192	7430	25681	103	110	190	170	24	138	18	26	17.5	50
80-12T6				81.8	73.688	6	280	10530	38521	103	110	246	170	24	138	18	26	17.5	50
80-16T3		16	9.525	82.2	72.466	3	188	9663	31622	108	115	208	174	24	143	18	26	17.5	50
80-16T4				82.2	72.466	4	254	12375	42162	108	115	244	174	24	143	18	26	17.5	50
80-20T3	20	9.525	82.2	72.466	3	189	9663	31622	108	115	250	174	24	143	18	26	17.5	50	
80-20T4			82.2	72.466	4	248	12375	42162	108	115	296	174	24	143	18	26	17.5	50	
100-12T4	100	12	101.8	93.688	4	206	8306	33001	123	130	190	190	24	158	18	26	17.5	50	
100-12T6			101.8	93.688	6	343	11772	49502	123	130	246	190	24	158	18	26	17.5	50	
100-16T4		16	9.525	102.2	92.466	4	212	13569	53161	135	135	244	194	24	163	18	26	17.5	60
100-16T6				102.2	92.466	6	276	19230	79741	135	135	318	194	24	163	18	26	17.5	60
100-20T4	20	9.525	102.2	92.466	4	300	13569	53161	135	135	296	194	24	163	18	26	17.5	60	

Remark : Stiffness values listed above are derived from theoretical formula while preload is 10% of dynamic load rating.