

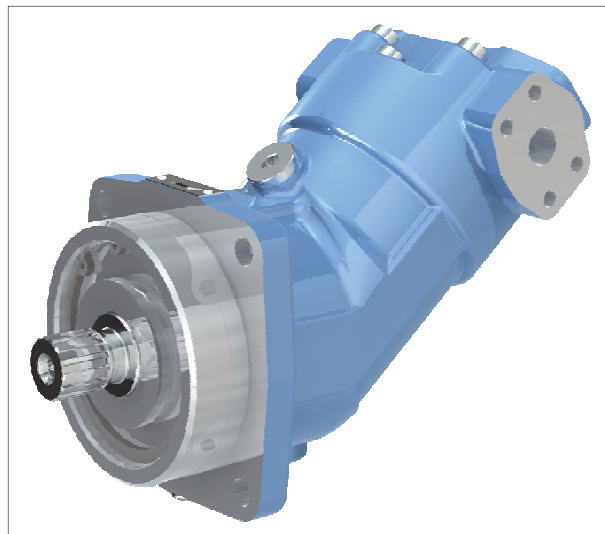

BREVINI[®]

Motion Systems



SH11C

POMPE A CILINDRATA FISSA

FIXED DISPLACEMENT PUMPS

DESCRIZIONE - CARATTERISTICHE GENERAL INFORMATION - FEATURES

Le pompe della serie SH11C sono una famiglia di unità a pistoni assiali, a corpo inclinato, a cilindrata fissa, progettati per operare in circuito aperto. Il distributore a superficie sferica, l'accurata lavorazione e l'alta qualità dei materiali e dei componenti usati, consentono alle pompe della serie SH11C di lavorare fino a 430 bar in continuo e di sopportare picchi di 480 bar. Provati in laboratorio e sperimentati sul campo queste unità hanno dimostrato una lunga durata di esercizio con elevati rendimenti. Il supporto dell'albero, realizzato mediante cuscinetti a rotolamento, è dimensionato in modo da sopportare elevati carichi assiali e radiali. La versatilità delle serie SH11C, consente a queste unità di essere idonee alle diverse tipologie di impianto, sia nel settore mobile che in quello industriale. Le pompe SH11C sono disponibili in versione ISO e in versione SAE.

SH11C pumps are a family of fixed displacement, bent axis piston design for operation in open circuit. The proven design incorporating the lens shape valve plate, the high quality components and manufacturing techniques make the SH11C pumps to able provide up to 430 bar [6235 psi] continuous and 480 bar [6960 psi] peak performance. Fully laboratory tested and field proven, these pumps provide maximum efficiency and longlife. Heavy duty bearings permit high radial and axial loads.

Versatile design will be fit the SH11C pumps to any application both industrial and mobile. SH11C pumps are available in both ISO and SAE version.

Fluidi:

Utilizzare fluidi a base minerale con additivi anticorrosione, antiossidanti e antiusura (HL o HM) con viscosità alla temperatura di esercizio di 15 ÷ 40 cSt. Una viscosità limite di 800 cSt è ammissibile solo per brevi periodi in Condizione di partenza a freddo, per valori superiori contattare Dana Brevini. Non sono ammesse viscosità inferiori ai 10 cSt. Viscosità comprese tra i 10 e i 15 cSt sono tollerate solo in casi eccezionali e per brevi periodi.

Hydraulic fluids:

Use fluids with mineral oil basis and anticorrosive, antioxidant and wear preventing addition agents (HL or HM). Viscosity range at operating temperature must be of 15 ÷ 40 cSt. For short periods and upon cold start, a max. viscosity of 800 cSt is allowed, for different types of viscosity please contact Dana Brevini. Viscosities less than 10 cSt are not allowed. A viscosity range of 10 ÷ 15 cSt is allowed for extreme operating conditions and for short periods only.

Temperature:

Non è ammesso il funzionamento dell'unità a pistoni con temperature del fluido idraulico superiori a 115°C e inferiori a -25°C. Per applicazioni con temperature inferiori contattare Dana Brevini.

Temperature ranges:

The operating temperature of the oil must be within -25°C ÷ 115°C [-13°F ÷ 239°F]. For applications with lower temperatures please contact Dana Brevini.

Filtrazione:

Una corretta filtrazione contribuisce a prolungare la durata in esercizio dell'unità a pistoni. Per un corretto impiego dell'unità a pistoni la classe di contaminazione massima ammessa è 21/19/16 secondo la ISO 4406:1999.

Filtering:

A correct filtering is essential for long and satisfactory life of axial piston units. In order to ensure a correct functioning of the unit, the max. permissible contamination class is 21/19/16 according to ISO 4406:1999.

Pressione in carcassa:

La pressione massima ammissibile in carcassa è di 10 bar. Una pressione superiore può compromettere la durata e la funzionalità della guarnizione dell'albero di uscita.

Case drain pressure:

Maximum permissible case drain pressure is 10 bar [145 psi]. A higher pressure can damage the main shaft seal or reduce its life.

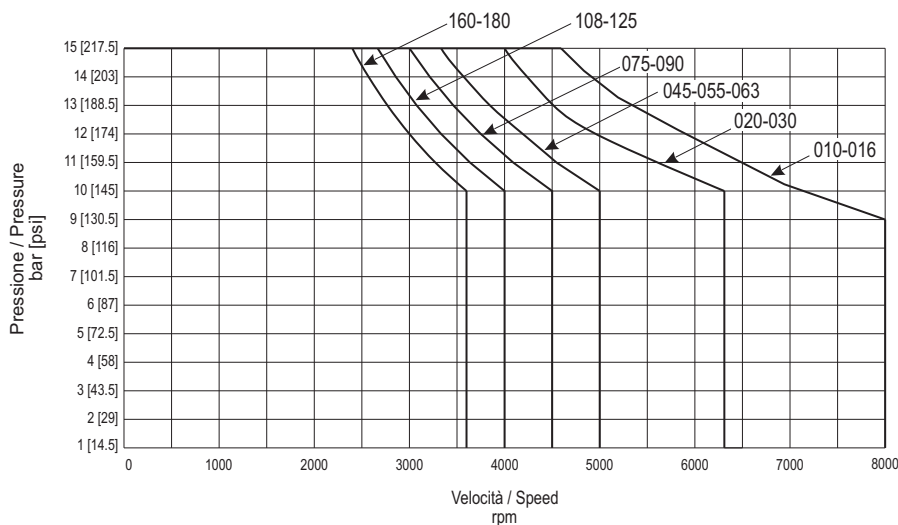

Albero di uscita:

La tabella è una guida per la determinazione dei carichi accettabili. I valori sono determinati in modo da garantire una vita almeno pari all'80% della vita dei cuscinetti in assenza di carico esterno. I valori sono riferiti a carichi applicati nella mezzeria dell'albero e nella direzione più sfavorevole.

Output shaft:

Table is a guide to determine max. permissible loads. Values are calculated in such a way to assure at least 80% of the bearing operating life where no external load is applied. The published values are related to loads applied in the middle of shaft and in the least favourable direction.

| Cilindrata / Displacement | | | 010* | 016* | 020 | 030 | 045* | 055 | 063 | 075 | 090 | 108 | 125 | 160 | 180 | |
|--|--|---------------------------|-----------------------|-----------------|-----------------|------------------|------------------|-------------------------------|----------------------------------|----------------------------------|----------------------------------|--------------------------------|----------------------------------|--------------------------------|--------------------------------|-----------------|
| | Forza radiale Radial load ($F_{q \max}$) | N [lbf] | 3000 [674.4] | 3200 [719.4] | 4300 [967.5] | 6100 [1372.5] | 8350 [1877.2] | 9200 ⁽¹⁾ [2068] | 10300 ⁽¹⁾ [2317.5] | 11500 ⁽¹⁾ [2587.5] | 12900 ⁽¹⁾ [2902.5] | 13600 ⁽¹⁾ [3060] | 15900 ⁽¹⁾ [3577.5] | 18400 ⁽¹⁾ [4140] | 20600 ⁽¹⁾ [4635] | |
| | Carico Load | N/bar [lbf/psi] | 8.5 [0.128] | 9 [0.135] | 12 [0.18] | 19 [0.285] | 23.8 [0.357] | 25 [0.375] | 30 [0.45] | 25.7 [0.386] | 28.5 [0.428] | 35 [0.525] | 37 [0.555] | 41 [0.615] | 45 [0.675] | |
| | Forza assiale tirante Axial pulling load ($F_{ax \max}$) | N [lbf] | 250 bar [3625 psi] | 550 [123.6] | 850 [191.1] | 1000 [225] | 1300 [292.5] | 1740 [391.2] | 1920 [432] | 2150 [484] | 2300 [517.5] | 2800 [630] | 2900 [652.5] | 3300 [742.5] | 3800 [855] | 4050 [911.2] |
| | | | 350 bar [5075 psi] | 800 [179.8] | 1050 [236.0] | 1300 [292.5] | 1800 [405] | 2400 [539.5] | 2650 [596] | 2990 [673] | 3550 [798.75] | 3800 [855] | 4050 [911.25] | 4550 [1023.7] | 5300 [1192.5] | 5800 [1305] |
| Forza assiale spingente Axial pushing load ($F_{ax \max}$) | N [lbf] | < 100 bar [< 1450 psi] | 320 [71.9] | 320 [71.9] | 500 [112.5] | 500 [112.5] | 800 [179.8] | 800 [180] | 800 [180] | 1000 [225] | 1000 [225] | 1250 [281.25] | 1250 [281.25] | 1600 [360] | 1600 [360] | |
| | N/bar [lbf/psi] | > 100 bar [> 1450 psi] | 3 [0.045] | 3 [0.045] | 5 [0.075] | 5 [0.075] | 8.7 [0.131] | 9 [0.135] | 9 [0.135] | 12 [0.18] | 12 [0.18] | 13 [0.195] | 13 [0.195] | 17 [0.255] | 17 [0.255] | |

(*)
Massima forza radiale permessa per albero SAI (SH11C 055-063):
 $F_{q \max} = 6500$ N
Massima forza radiale permessa per albero SAM (SH11C 075-090):
 $F_{q \max} = 6500$ N
Massima forza radiale permessa per albero SAO (SH11C 108-125):
 $F_{q \max} = 6500$ N
Massima forza radiale permessa per albero SAP (SH11C 160-180):
 $F_{q \max} = 6500$ N

(*)
Max permissible radial force with SAI shaft (SH11C 055-063):
 $F_{q \max} = 6500$ N [1462.5 lbf]
Max permissible radial force with SAM shaft (SH11C 075-090):
 $F_{q \max} = 6500$ N [1462.5 lbf]
Max permissible radial force with SAO shaft (SH11C 108-125):
 $F_{q \max} = 6500$ N [1462.5 lbf]
Max permissible radial force with SAP shaft (SH11C 160-180):
 $F_{q \max} = 6500$ N [1462.5 lbf]

Quando un carico radiale esterno è applicato all'albero la vita dei cuscinetti è determinata dalla intensità, dalla posizione e dalla direzione della forza applicata. Il diagramma mostra come la vita dei cuscinetti varia con la direzione del carico. Nel diagramma il valore 100% rappresenta la vita dei cuscinetti in assenza di carico esterno. La direzione ottimale del carico dipende dalla bocca dell'unità a pistoni in pressione.

When an external side (radial) load is applied to the drive shaft, the bearing life will vary accordingly to the magnitude, location and direction of the load. The diagram shows how the bearing operating life varies versus the direction of the load. In the diagram 100% represents the bearing operating life where no external side load is applied to the drive shaft. The optimum direction is dependent on which port is pressurised.

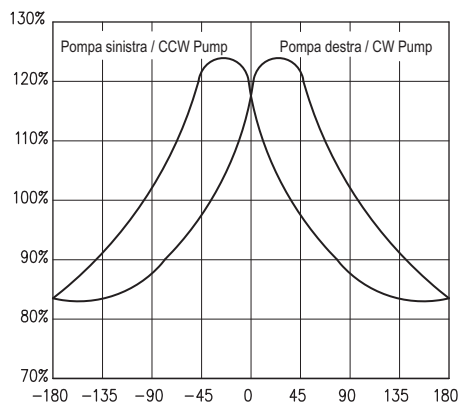

Il diagramma mostra che per determinate direzioni di carico è possibile avere incrementi di durata della vita dei cuscinetti anche del 30%. L'aumento massimo di durata dipende dalla pressione di esercizio e dalla dimensione nominale dell'unità a pistoni.

Nel considerare la forza assiale permessa bisogna fare attenzione alla direzione di trasferimento della forza:

- Carichi assiali spingenti incrementano la vita dei cuscinetti.
- Carichi assiali tiranti riducono la vita dei cuscinetti (se possibile i carichi tiranti devono essere evitati).

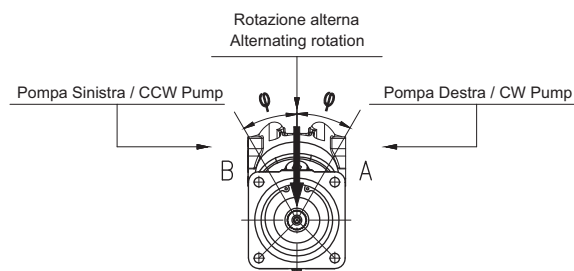

The bearing operating life increases up to 30% when the load is applied with some peculiar directions and the maximum increase is dependent on the operating pressure and the nominal size of the unit.

When considering the permissible axial force, the force - transfer direction must be taken in account:

- Pushing axial loads increase the bearing life.
- Pulling axial loads reduce the bearing life (if possible pulling axial loads should be avoided).

Guarnizioni:

Le guarnizioni utilizzate sulle unità a pistoni assiali SH11C sono in FKM (Fluoroelastomer). Nel caso di impiego di fluidi speciali contattare Dana Brevini.

Regime minimo di rotazione:

Se richiesta l'uniformità di erogazione di portata, la velocità minima non può essere minore di 500 rpm. Per applicazioni particolari contattare Dana Brevini.

Installazione:

L'installazione con albero verticale e al di sopra del serbatoio comporta alcune limitazioni. Per maggiori dettagli consultare nel Catalogo Informazioni Generali la sezione "Norme generali di installazione".

Relazione tra senso di rotazione e direzione di flusso:

La relazione tra il senso di rotazione dell'albero dell'unità e la direzione del flusso del fluido è illustrata in figura.

Seals:

Seals used on SH11C series are of FKM (Fluoroelastomer). In case of use of special fluids, contact Dana Brevini.

Minimum rotating speed:

If uniformity of constant flow is required, speed must not be less than 500 rpm. In case of use of special applications, contact Dana Brevini.

Installation:

Installation with shaft in vertical position and above the tank involves some limitations. For further details see on the General Information Catalogue, the section "General installation guidelines".

Relation between direction of rotation and direction of flow:

The relation between direction of rotation of shaft and direction of flow is shown in the picture below.

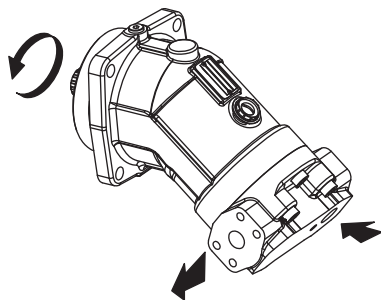

Pompa rotazione destra
CW rotating pump

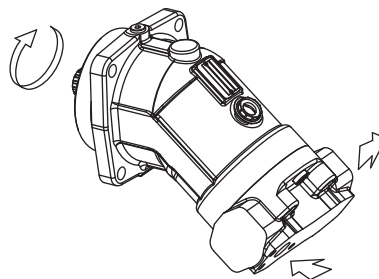

Pompa rotazione sinistra
CCW rotating pump

| Dimensione / Size | | | | 010* | 016* | 020 | 030 | 045* | 055 | 063 | 075 | 090 | 108 | 125 | 160 | 180 |
|---|--------------------------------------|---|--|--------------------|--------------------|-------------------|-------------------|------------------|------------------|------------------|-------------------|-------------------|-------------------|-------------------|-------------------|-------------------|
| Cilindrata Displacement | | Vg | cm ³ /rev [in ³ /rev] | 10.3 [0.626] | 16 [0.976] | 19.9 [1.213] | 31.9 [1.945] | 46 [2.807] | 56.35 [3.437] | 63.26 [3.859] | 77.82 [4.747] | 86.23 [5.26] | 108.4 [6.612] | 124.8 [7.613] | 163.9 [9.998] | 178.1 [10.864] |
| | Pressione max. Max. pressure | cont. | p _{nom} | bar [psi] | 430 [6235] | 430 [6235] | 430 [6235] | 430 [6235] | 430 [6235] | 430 [6235] | 430 [6235] | 430 [6235] | 430 [6235] | 430 [6235] | 430 [6235] | 430 [6235] |
| picco peak | | p _{max} | bar [psi] | 480 [6960] | 480 [6960] | 480 [6960] | 480 [6960] | 480 [6960] | 480 [6960] | 480 [6960] | 480 [6960] | 480 [6960] | 480 [6960] | 480 [6960] | 480 [6960] | 480 [6960] |
| Velocità max. Max. speed | | n _{1 max} cont. | rpm | 3150 | 3150 | 2500 | 2500 | 2245 | 2000 | 2000 | 1800 | 1800 | 1600 | 1550 | 1450 | 1450 |
| | | n _{1 max} int. ⁽¹⁾ | rpm | 6000 | 6000 | 4750 | 4750 | 4250 | 3750 | 3750 | 3350 | 3350 | 3000 | 3000 | 2650 | 2650 |
| Portata max. ⁽²⁾ Max. flow ⁽²⁾ | | q _{1 max} | l/min [U.S. gpm] | 32 [8.5] | 50 [13.2] | 50 [13.2] | 80 [21.1] | 103 [27.2] | 112 [29.5] | 127 [33.5] | 140 [36.96] | 155 [40.92] | 173 [45.67] | 193 [50.95] | 237 [62.57] | 258 [68.2] |
| Potenza max. a p _{nom} ⁽²⁾ Max. power at p _{nom} ⁽²⁾ | | P _{1 max} | kW [hp] | 23 [30.8] | 35.8 [48] | 35.8 [48] | 57 [76.4] | 74 [99.2] | 80.3 [107.6] | 91 [24.0] | 100 [134] | 111 [148.7] | 124 [166.2] | 138 [184.9] | 170 [227.8] | 185 [48.9] |
| Coppia max. Max. torque | cont. (p _{nom}) | T _{nom} | Nm [lbf-ft] | 71 [52.36] | 110 [81.13] | 136 [100.23] | 218 [160.66] | 315 [232.33] | 386 [284.48] | 433 [319.12] | 533 [392.82] | 590 [435.13] | 742 [546.85] | 855 [630.13] | 1122 [826.91] | 1219 [898.40] |
| | picco peak (p _{max}) | T _{max} | Nm [lbf-ft] | 79 [58.27] | 122 [89.98] | 152 [112.02] | 243 [179.09] | 352 [260.36] | 431 [317.65] | 484 [356.71] | 595 [438.51] | 659 [486.05] | 829 [610.97] | 954 [703.10] | 1253 [923.46] | 1361 [1003.06] |
| Momento di inerzia ⁽³⁾ Moment of inertia ⁽³⁾ | | J | kg·m ² [lbf-ft ²] | 0.0005 [0,0118] | 0.0005 [0,0118] | 0.001 [0.0235] | 0.001 [0.0235] | 0.004 [0.094] | 0.004 [0.094] | 0.004 [0.094] | 0.007 [0.1645] | 0.007 [0.1645] | 0.012 [0.2820] | 0.012 [0.2820] | 0.022 [0.5170] | 0.022 [0.5170] |
| Peso ⁽³⁾ Weight ⁽³⁾ | | m | kg [lbs] | 6 [13.22] | 6 [13.22] | 10 [22.04] | 10 [22.04] | 18 [39.68] | 19 [41.876] | 19 [41.876] | 23.7 [52.23] | 23.7 [52.23] | 35 [77.14] | 35 [77.14] | 48 [105.79] | 48 [105.79] |
| Portata di drenaggio ⁽⁴⁾ External drain flow ⁽⁴⁾ | | q _d | l/min [U.S. gpm] | 0.8 [0.2113] | 0.8 [0.2113] | 1 [0.264] | 1 [0.264] | 1.2 [0.317] | 1.2 [0.317] | 1.2 [0.317] | 2.5 [0.66] | 2.5 [0.66] | 3 [0.79] | 3 [0.79] | 3 [0.79] | 3 [0.79] |

* In fase di completamento - Work in progress

(Valori teorici, senza considerare η_{hm} e η_v ; valori arrotondati). Le condizioni di picco non devono durare più dell'1% di ogni minuto. Evitare il funzionamento contemporaneo alla massima velocità e alla massima pressione.

(Theoretical values, without considering η_{hm} e η_v approximate values). Peak operations must not exceed 1% of every minute. A simultaneous maximum pressure and maximum speed not recommended.

Note: Determinazione della velocità ammissibile

⁽¹⁾ La velocità di rotazione della pompa può essere aumentata aumentando la pressione sulla bocca di aspirazione. Per la determinazione della velocità massima di rotazione ammissibile in funzione della pressione sulla bocca di aspirazione utilizzare il diagramma a lato. ⁽²⁾ Valori validi per un regime di rotazione pari ad n_{1 max} cont. ⁽³⁾ Valori indicativi. ⁽⁴⁾ Valori medi a 250 bar con olio minerale a 45°C e viscosità 35 cSt.

Notes: Calculation of permissible speed

⁽¹⁾ The pump rotation speed may be increased by increasing the suction pressure. To calculate the max. permissible speed related to the pump suction pressure see the diagram at side. ⁽²⁾ The values are valid for a rotating speed of n_{1 max} cont. ⁽³⁾ Approximate values. ⁽⁴⁾ Average values at 250 bar [3600 psi] with mineral oil at 45°C [113°F] and 35 cSt of viscosity.

Determinazione della velocità limite / Speed limits calculation

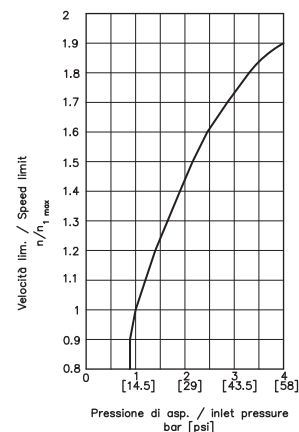

CODICE DI ORDINAZIONE ORDERING CODE

Le seguenti lettere o numeri del codice, sono state sviluppate per identificare tutte le configurazioni possibili delle pompe SH11C. Usare il seguente modulo per identificare le caratteristiche desiderate. **Tutte le lettere o numeri del codice devono comparire in fase d'ordine.** Si consiglia di leggere attentamente il catalogo prima di iniziare la compilazione del codice di ordinazione.

The following alphanumeric codes system has been developed to identify all of the configuration options for the SH11C pumps. Use the model code below to specify the desired features. **All alphanumeric digits system of the code must be present when ordering.** We advise to carefully read the catalogue before filling the ordering code.

CODICE PRODOTTO / MODEL CODE

| | | | | | | | | | | | | | |
|---|---|---|---|---|---|---|---|---|----|----|----|----|----|
| 1 | 2 | 3 | 4 | 5 | 6 | 7 | 8 | 9 | 10 | 11 | 12 | 13 | 14 |
| | | | | | | | | | | | | | |

1 - SERIE / SERIES

| | |
|-------|---|
| SH11C | Unità a pistoni assiali, con corpo inclinato a cilindrata fissa Fixed displacement, bent axis, axial piston unit |
|-------|---|

2 - POMPA / PUMP

| | |
|---|---------------|
| P | Pompa Pump |
|---|---------------|

3 - CILINDRATA / DISPLACEMENT

| | | |
|------|----------------------------|----------------------------|
| 010* | 10.3 cm ³ /giro | 0.626 in ³ /rev |
| 016* | 16 cm ³ /giro | 0.976 in ³ /rev |
| 020 | 20 cm ³ /giro | 1.22 in ³ /rev |
| 030 | 30 cm ³ /giro | 1.83 in ³ /rev |
| 045* | 46 cm ³ /giro | 2.807 in ³ /rev |
| 055 | 55 cm ³ /giro | 3.355 in ³ /rev |
| 063 | 63 cm ³ /giro | 3.843 in ³ /rev |
| 075 | 75 cm ³ /giro | 4.575 in ³ /rev |
| 090 | 90 cm ³ /giro | 5.49 in ³ /rev |
| 108 | 108 cm ³ /giro | 6.588 in ³ /rev |
| 125 | 125 cm ³ /giro | 7.625 in ³ /rev |
| 160 | 160 cm ³ /giro | 9.76 in ³ /rev |
| 180 | 180 cm ³ /giro | 10.98 in ³ /rev |

4 - VERSIONE / VERSION

| | |
|----|-----|
| ME | ISO |
| SE | SAE |

CILINDRATA / DISPLACEMENT

| | | 010*-016* | 020-030 | 045*-055-063 | 075-090 | 108-125 | 160-180 |
|-----------------------------------|--|-----------|---------|--------------|---------|---------|---------|
| 5 - FLANGIA / MOUNT FLANGE | | | | | | | |
| OA | ISO 4 fori Ø 80 mm ISO 4 Bolts Ø 80 mm [Ø 3.15 in] | ME | / | / | / | / | / |
| OB | ISO 4 fori Ø 100 mm ISO 4 Bolts Ø 100 mm [Ø 3.937 in] | / | ME | / | / | / | / |
| OC | ISO 4 fori Ø 125 mm ISO 4 Bolts Ø 125 mm [Ø 4.921 in] | / | / | ME | / | / | / |
| OD | ISO 4 fori Ø 140 mm ISO 4 Bolts Ø 140 mm [Ø 5.511 in] | / | / | / | ME | / | / |
| OE | ISO 4 fori Ø 160 mm ISO 4 Bolts Ø 160 mm [Ø 6.299 in] | / | / | / | / | ME | / |
| OF | ISO 4 fori Ø 180 mm ISO 4 Bolts Ø 180 mm [Ø 7.086 in] | / | / | / | / | / | ME |
| 02 | SAE-C 4 Fori SAE-C 4 Bolts | SE | / | / | / | / | / |
| 05 | SAE-C 4 Fori SAE-C 4 Bolts | / | SE | SE | SE | / | / |
| 08 | SAE-D 4 Fori SAE-D 4 Bolts | / | / | / | / | SE | SE |

* In fase di completamento - Work in progress

1) Il valore ME indica che la flangia è disponibile solo per la versione ISO
The ME digit means that the flange is only available for the ISO version

2) Il valore SE indica che la flangia è disponibile solo per la versione SAE
The SE digit means that the flange is only available for the SAE version

| | | | | | | | | | | | | | |
|---|---|---|---|---|---|---|---|---|----|----|----|----|----|
| 1 | 2 | 3 | 4 | 5 | 6 | 7 | 8 | 9 | 10 | 11 | 12 | 13 | 14 |
|---|---|---|---|---|---|---|---|---|----|----|----|----|----|

| | | CILINDRATA / DISPLACEMENT | | | | | |
|---|---|---------------------------|---------|--------------|---------|---------|---------|
| | | 010*-016* | 020-030 | 045*-055-063 | 075-090 | 108-125 | 160-180 |
| 6 - ESTREMITÀ ALBERO / SHAFT END | | | | | | | |
| CAV | Cilindrico Ø20 mm k6 - Linguetta 8x6x30 Parallel keyed Ø20 mm k6 [0.984 in k6] - Key 0.23x0.23x1.18 | ME | / | / | / | / | / |
| CMB | Cilindrico Ø25 mm k6 - Linguetta 8x7x32 Parallel keyed Ø 25 mm k6 [0.984 in k6] - Key 0.31x0.27x1.57 | ME | / | / | / | / | / |
| CBM | Cilindrico Ø25 mm k6 - Linguetta 8x7x40 Parallel keyed Ø 25 mm k6 [0.984 in k6] - Key 0.31x0.27x1.57 | / | ME | / | / | / | / |
| CBN | Cilindrico Ø 30 mm k6 - Linguetta 8x7x40 Parallel keyed Ø 30 mm k6 [1.181 in k6] - Key 0.31x0.27x1.57 | / | ME | / | / | / | / |
| CAW | Cilindrico Ø 30 mm k6 - Linguetta 8x7x50 Parallel keyed Ø 30 mm k6 [1.181 in k6] - Key 0.31x0.27x1.97 | / | / | ME | / | / | / |
| CBP | Cilindrico Ø 40 mm k6 - Linguetta 12x8x56 Parallel keyed Ø 40 mm k6 [1.574 in k6] - Key 0.47x0.31x2.204 | / | / | / | ME | / | / |
| CAK | Cilindrico Ø 40 mm k6 - Linguetta 12x8x63 Parallel keyed Ø 40 mm k6 [1.574 in k6] - Key 0.47x0.31x2.48 | / | / | / | / | ME | / |
| CAJ | Cilindrico Ø 45 mm k6 - Linguetta 14x9x63 Parallel keyed Ø 45 mm k6 [1.772 in k6] - Key 0.55x0.35x2.48 | / | / | / | / | ME-SE | / |
| CBQ | Cilindrico Ø 45 mm k6 - Linguetta 14x9x70 Parallel keyed Ø 45 mm k6 [1.772 in k6] - Key 0.55x0.35x2.75 | / | / | / | / | / | ME |
| CAX | Cilindrico Ø 50 mm k6 - Linguetta 14x9x70 Parallel keyed Ø 50 mm k6 [1.968 in k6] - Key 0.55x0.35x2.75 | / | / | / | / | / | ME-SE |
| CAY | Cilindrico Ø 35 mm k6 - Linguetta 10x8x56 Parallel keyed Ø 35 mm k6 [1.377 in k6] - Key 0.39x0.31x2.204 | / | / | / | ME | / | / |
| SAF | Scanalato W20x1.25x30x14x9g DIN 5480 Splined W20x1.25x30x14x9g DIN 5480 | ME | / | / | / | / | / |
| SAG | Scanalato W25x1.25x18x9g DIN 5480 Splined W25x1.25x18x9g DIN 5480 | ME | ME | / | / | / | / |
| SAI | Scanalato W30x2x14x9g DIN 5480 Splined W30x2x14x9g DIN 5480 | / | ME | ME | / | / | / |
| SAM | Scanalato W35x2x16x9g DIN 5480 Splined W35x2x16x9g DIN 5480 | / | / | ME | ME | / | / |
| SAO | Scanalato W40x2x18x9g DIN 5480 Splined W40x2x18x9g DIN 5480 | / | / | / | ME | ME | / |
| SAP | Scanalato W45x2x21x9g DIN 5480 Splined W45x2x21x9g DIN 5480 | / | / | / | / | ME | ME |
| SAR | Scanalato W50x2x24x9g DIN 5480 Splined W50x2x24x9g DIN 5480 | / | / | / | / | / | ME |
| C16 | Cilindrico Ø 22.22 mm - Linguetta 6.35x6.25x25.4 Parallel keyed Ø 22.22 mm [0.874 in] - Key 0.25x0.246x1 | / | SE | / | / | / | / |
| C17 | Cilindrico Ø 31.75 mm - Linguetta 7.93x7.3x40 Parallel keyed Ø 31.75 mm [1.25 in] - Key 0.31x0.287x1.57 | / | / | SE | / | / | / |
| C18 | Cilindrico Ø 44.45 mm - Linguetta 11.11x9.2x60 Parallel keyed Ø 44.45 mm [1.75 in] - Key 0.43x0.36x2.36 | / | / | / | / | SE | SE |
| S05 | Scanalato Z13 16/32 DP Splined 13T 16/32 DP | SE | SE | / | / | / | / |
| S12 | Scanalato Z14 12/24 DP Splined 14T 12/24 DP | / | SE | SE | SE | / | / |
| S15 | Scanalato Z13 8/16 DP Splined 13T 8/16 DP | / | / | / | / | SE | SE |
| S16 | Scanalato Z23 16/32 DP Splined 23T 16/32 DP | / | / | / | / | SE | / |

* In fase di completamento - Work in progress

- Il valore ME indica che l'albero è disponibile solo per la versione ISO
The ME digit means that the shaft is only available for the ISO version
- Il valore SE indica che l'albero è disponibile solo per la versione SAE
The SE digit means that the shaft is only available for the SAE version

| | | | | | | | | | | | | | |
|---|---|---|---|---|---|---|---|---|----|----|----|----|----|
| 1 | 2 | 3 | 4 | 5 | 6 | 7 | 8 | 9 | 10 | 11 | 12 | 13 | 14 |
| | | | | | | | | | | | | | |

CILINDRATA / DISPLACEMENT

| | | | | | |
|-----------|---------|--------------|---------|---------|---------|
| 010*-016* | 020-030 | 045*-055-063 | 075-090 | 108-125 | 160-180 |
|-----------|---------|--------------|---------|---------|---------|

7 - COPERCHIO DISTRIBUTORE / PORT COVER

| | | | | | | | |
|------------|--|-------|-------|-------|-------|-------|-------|
| FP2 | Bocche Frontali (Pompa) Frontal ports (Pompa) | ME-SE | ME-SE | ME-SE | ME-SE | ME-SE | ME-SE |
|------------|--|-------|-------|-------|-------|-------|-------|

* In fase di completamento - Work in progress

- 1) Il valore ME indica che il coperchio è disponibile solo per la versione ISO
The ME digit means that the port cover is only available for the ISO version
2) Il valore SE indica che il coperchio è disponibile solo per la versione SAE
The SE digit means that the port cover is only available for the SAE version

8 - SENSO DI ROTAZIONE (VISTA LATO ALBERO) / DIRECTION OF ROTATION (VIEWED FROM SHAFT SIDE)

| | |
|-----------|-----------------|
| DX | Destra CW |
| SX | Sinistra CCW |

9 - TENUTA / SEAL

| | |
|----------|-----|
| V | FKM |
|----------|-----|

10 - VALVOLA / VALVE

| | |
|-------------|-----------------------|
| XXXX | Non Richieste NONE |
|-------------|-----------------------|

| | | | | | | | | | | | | | |
|---|---|---|---|---|---|---|---|---|----|----|----|----|----|
| 1 | 2 | 3 | 4 | 5 | 6 | 7 | 8 | 9 | 10 | 11 | 12 | 13 | 14 |
|---|---|---|---|---|---|---|---|---|----|----|----|----|----|

| VALVOLA / VALVE | | | | | | |
|-----------------|------|------|------|------|------|------|
| XXXX | VCDM | VCD1 | VCD2 | VCR1 | VCR3 | VU16 |

| 11 - CARATTERISTICA VALVOLA / VALVE FEATURE | | | | | | | | |
|---|---|---|---|---|---|---|---|---|
| 000 | Caratteristica non necessaria Feature not necessary | • | / | / | / | / | • | / |
| 001 | Non Tarata (Campo Taratura 30+350 bar) (Rapporto di pilotaggio 6.2:1) Not Set 30+350 bar [435 to 5075 psi] [Piloting ratio 6.2:1] | / | / | / | / | • | / | / |
| 002 | Non Tarata (Campo Taratura 0+350 bar) (Rapporto di pilotaggio 2.9:1) - Controllo in rotazione DX Not Set 0+350 bar [0 to 5075 psi] [Piloting ratio 2.9:1] - Control of rotation CW | / | / | • | / | / | / | / |
| 006 | Non Tarata (Campo Taratura 0+350 bar) (Rapporto di pilotaggio 2.9:1) - Controllo in rotazione SX Not Set 0+350 bar [0 to 5075 psi] [Piloting ratio 2.9:1] - Control of rotation CCW | / | / | • | / | / | / | / |
| 004 | Non Tarata (Campo Taratura 30+350 bar) (Rapporto di pilotaggio 6.2:1) - Controllo in rotazione DX Not Set 30+350 bar [435 to 5075 psi] [Piloting ratio 6.2:1] - Control of rotation CW | / | • | / | / | / | / | / |
| 005 | Non Tarata (Campo Taratura 30+350 bar) (Rapporto di pilotaggio 6.2:1) - Controllo in rotazione SX Not Set 30+350 bar [435 to 5075 psi] [Piloting ratio 6.2:1] - Control of rotation CCW | / | • | / | / | / | / | / |
| 003 | Non Tarata (Campo Taratura 250+500 bar) (Rapporto di pilotaggio 13:1) - Controllo in rotazione DX Not Set 250+500 bar [3625 to 7250 psi] [Piloting ratio 13:1] - Control of rotation CW | / | / | / | • | / | / | / |
| 007 | Non Tarata (Campo Taratura 250+500 bar) (Rapporto di pilotaggio 13:1) - Controllo in rotazione SX Not Set 250+500 bar [3625 to 7250 psi] [Piloting ratio 13:1] - Control of rotation CCW | / | / | / | • | / | / | / |
| 008 | Non Tarata (Taratura Massima 350 bar, Portata Massima 65 l/min) - Controllo in rotazione DX Not Set (Max setting 350 bar[5075 psi], Max Flow 65 l/min [17.2 U.S. gpm]) - Control of rotation CW | / | / | / | / | / | / | • |
| 009 | Non Tarata (Taratura Massima 350 bar, Portata Massima 65 l/min) - Controllo in rotazione SX Not Set (Max setting 350 bar[5075 psi], Max Flow 65 l/min [17.2 U.S. gpm]) - Control of rotation CCW | / | / | / | / | / | / | • |

• Disponibile - Available / Non Disponibile - Not Available

Per la fornitura di valvole tarate contattare Uff. Tecnico.
Please contact Technical department for valve which require specific setting

Per le caratteristiche vedere il catalogo valvole
For the technical specifications see catalogue valves

| 12 - VALVOLA DI LAVAGGIO / FLUSHING VALVE | |
|---|-----------------------|
| XX | Non Richieste NONE |

| CILINDRATA / DISPLACEMENT | | | | | |
|---------------------------|---------|--------------|---------|---------|---------|
| 010*-016* | 020-030 | 045*-055-063 | 075-090 | 108-125 | 160-180 |

| 13 - CARATTERISTICA SPECIALE / SPECIAL FEATURE | | | | | | | |
|--|---|---|---|---|---|---|---|
| XX | Nessuna Caratteristica NONE | • | • | • | • | • | • |
| RD | Tappi drenaggio invertiti Drain plugs reversed | / | • | • | • | • | • |

• Disponibile - Available / Non Disponibile - Not Available * In fase di completamento - Work in progress

| 14 - VERNICIATURA / PAINTING | |
|------------------------------|---|
| XX | Non Richieste NONE |
| 01 | Verniciato RAL 9005 Painted RAL 9005 |
| 02 | Verniciato RAL 5015 Painted RAL 5015 |

S1, S2: Drenaggi (1 tappato) / Drain ports (1 plugged) - 3/8 G (BSPP)

A, B: UtENZE / Service line ports

R: Spurgo (tappato) / Air bleed (plugged) - 1/8 G (BSPP)

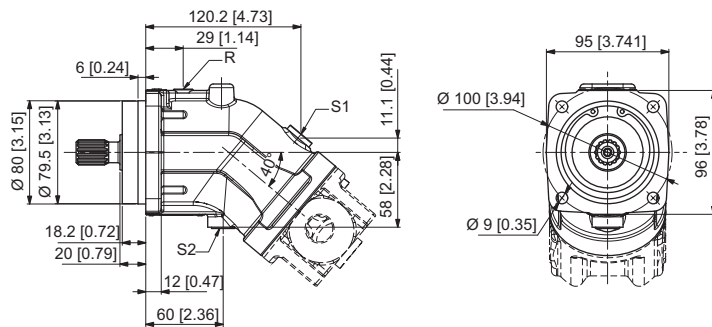

FP2

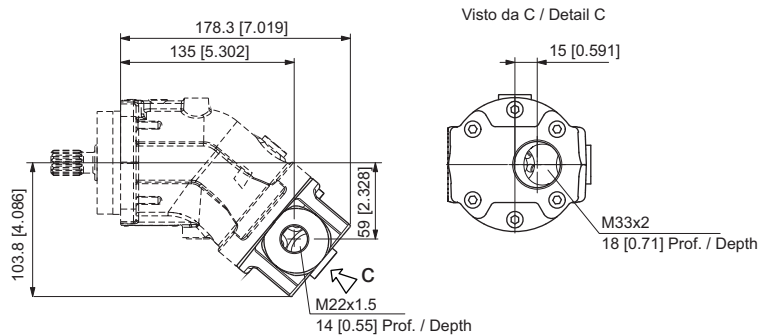

CAV *Albero cilindrico*
Parallel keyed shaft

CMB *Albero cilindrico*
Parallel keyed shaft

SAG *Albero scanalato*
Splined shaft

SAF *Albero scanalato*
Splined shaft

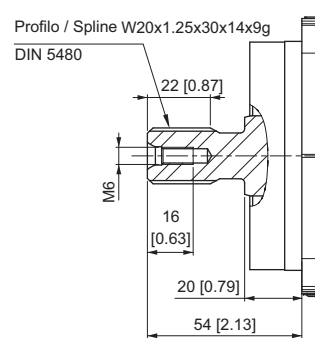
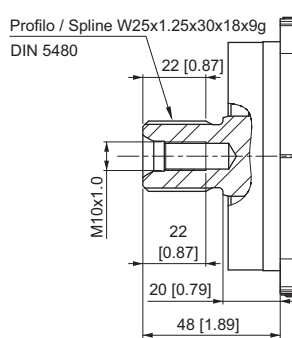
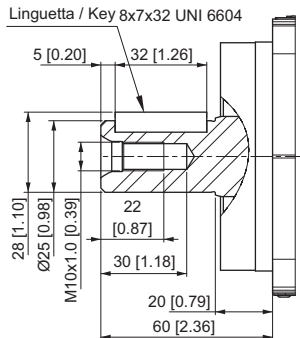
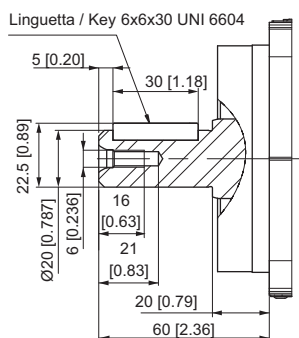

S1, S2: Drenaggi (1 tappato) / Drain ports (1 plugged) - 3/8 G (BSPP)
A, B: UtENZE / Service line ports
R: Spurgo (tappato) / Air bleed (plugged) - 1/8 G (BSPP)

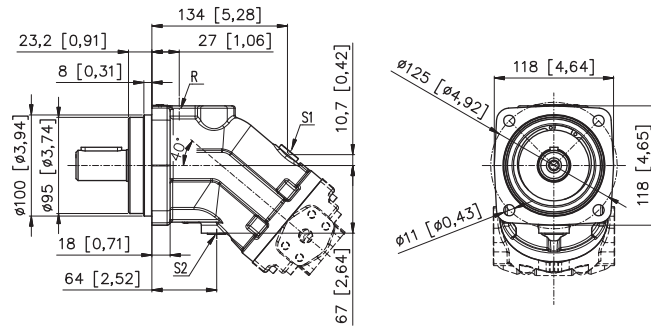

FP2

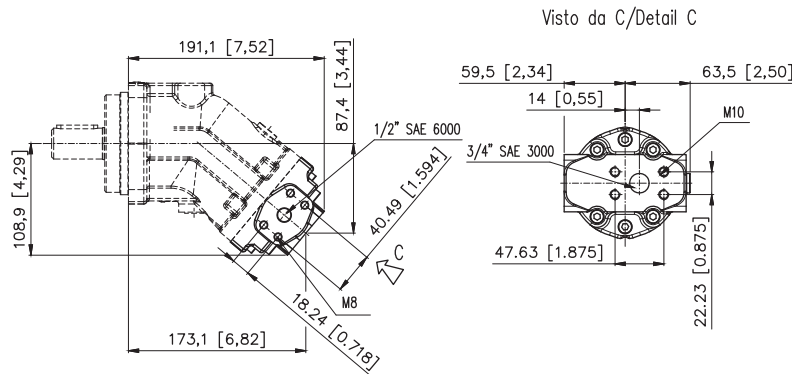

CBM *Albero cilindrico*
Parallel keyed shaft

CBN *Albero cilindrico*
Parallel keyed shaft

SAG *Albero scanalato*
Splined shaft

SAI *Albero scanalato*
Splined shaft

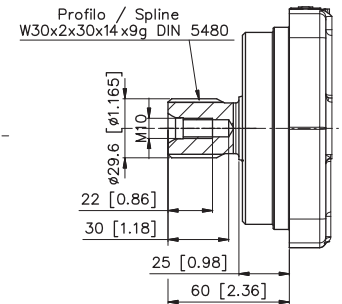
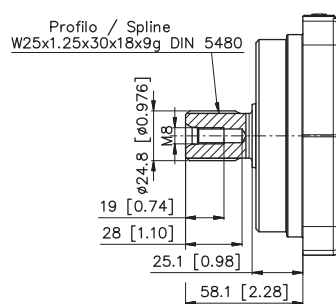
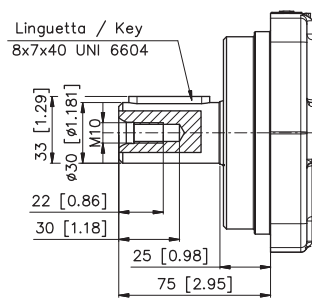
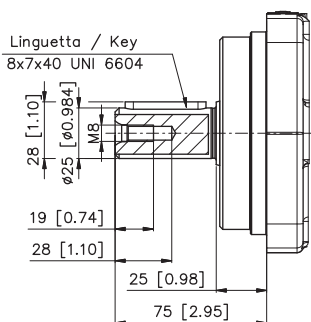

S1, S2: Drenaggi (1 tappato) / Drain ports (1 plugged) - 1/2 G (BSPP)
 A, B: Utenze / Service line ports
 R: Spurgo (tappato) / Air bleed (plugged) - 1/8 G (BSPP)

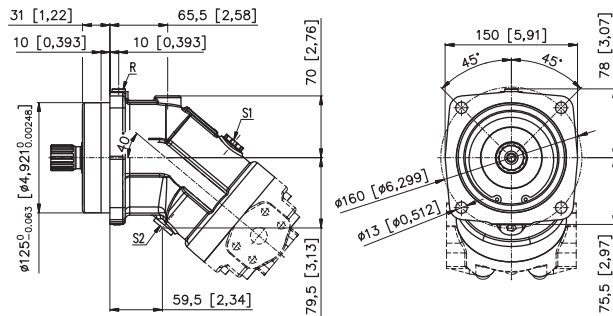

FP2

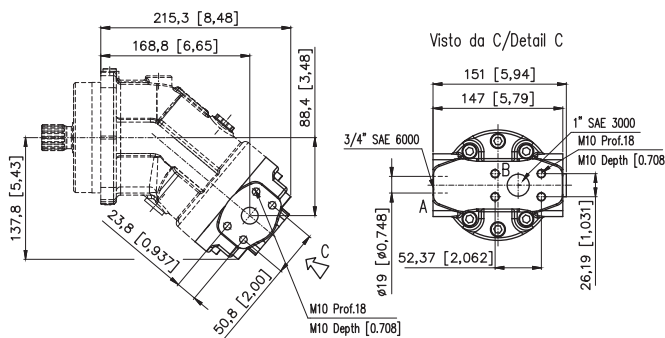

CAW *Albero cilindrico*
Parallel keyed shaft

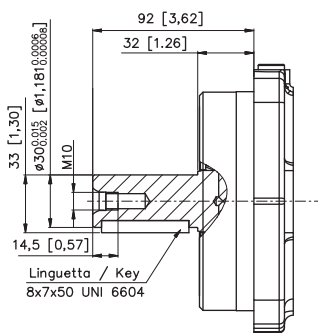

SAM *Albero scanalato*
Splined shaft

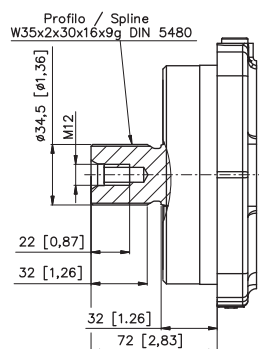

SAI *Albero scanalato*
Splined shaft

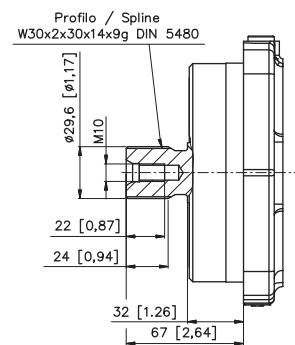

S1, S2: Drenaggi (1 tappato) / Drain ports (1 plugged) - 1/2 G (BSPP)
 A, B: Utenze / Service line ports
 R: Spurgo (tappato) / Air bleed (plugged) - 1/8 G (BSPP)

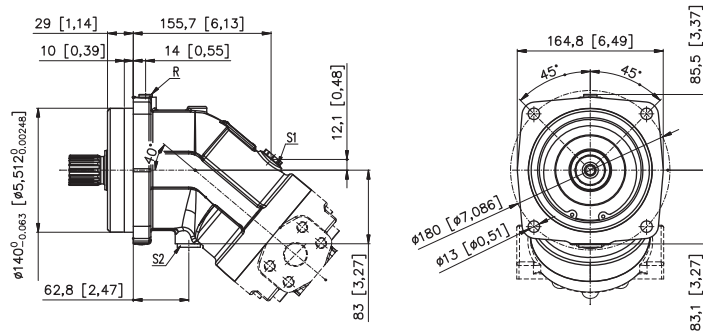

FP2

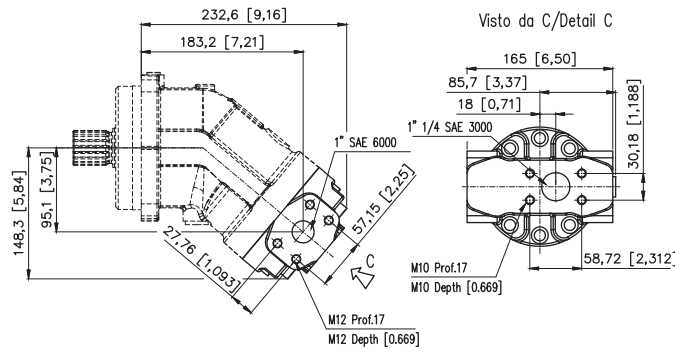

CAY *Albero cilindrico*
Parallel keyed shaft

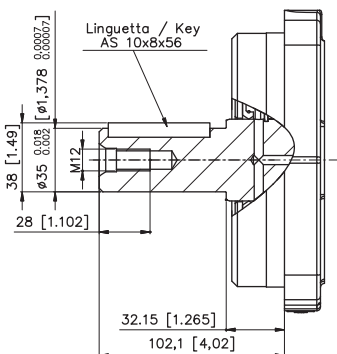

CBP *Albero cilindrico*
Parallel keyed shaft

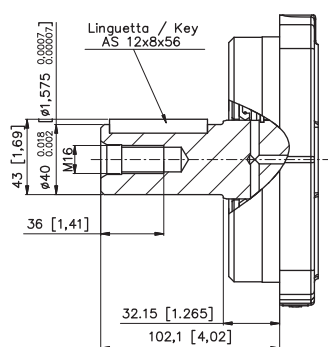

SAM *Albero scanalato*
Splined shaft

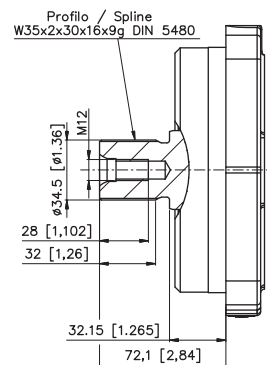

SAO *Albero scanalato*
Splined shaft

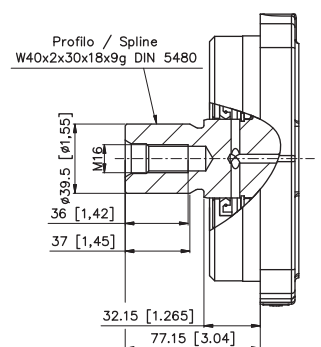

S1, S2: Drenaggi (1 tappato) / Drain ports (1 plugged) - 1/2 G (BSPP)

A, B: Utenze / Service line ports

R: Spurgo (tappato) / Air bleed (plugged) - 1/8 G (BSPP)

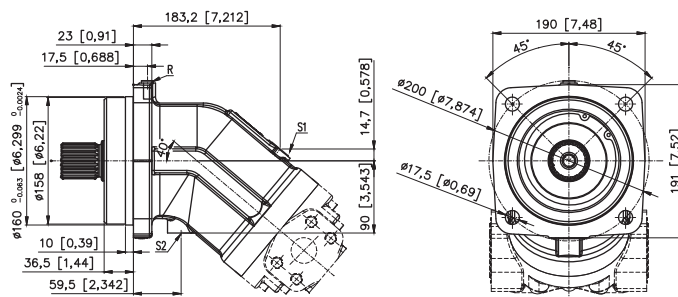

FP2

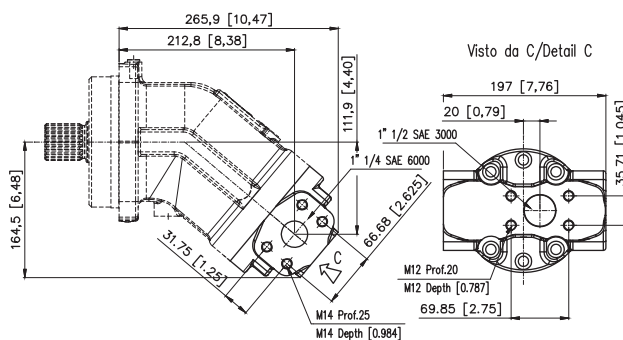

CAK *Albero cilindrico*
Parallel keyed shaft

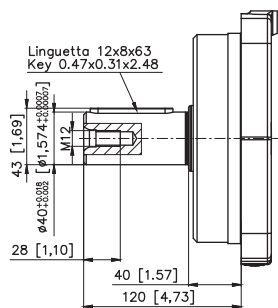

CAJ *Albero cilindrico*
Parallel keyed shaft

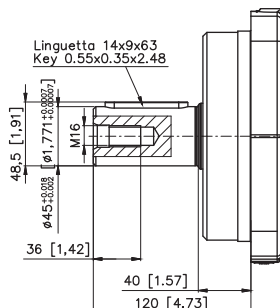

SAO *Albero scanalato*
Splined shaft

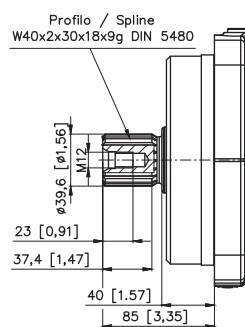

SAP *Albero scanalato*
Splined shaft

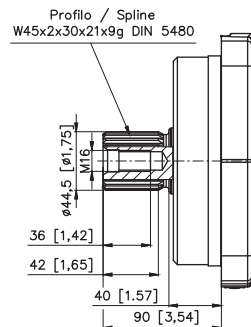

S1, S2: Drenaggi (1 tappato) / Drain ports (1 plugged) - 3/4 G (BSPP)

A, B: Utenze / Service line ports

R: Spurgo (tappato) / Air bleed (plugged) - 1/8 G (BSPP)

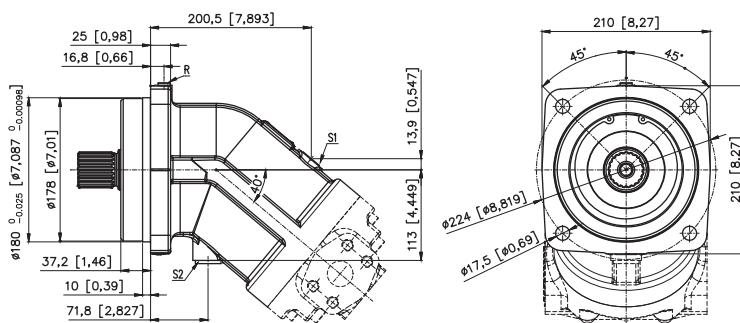

FP2

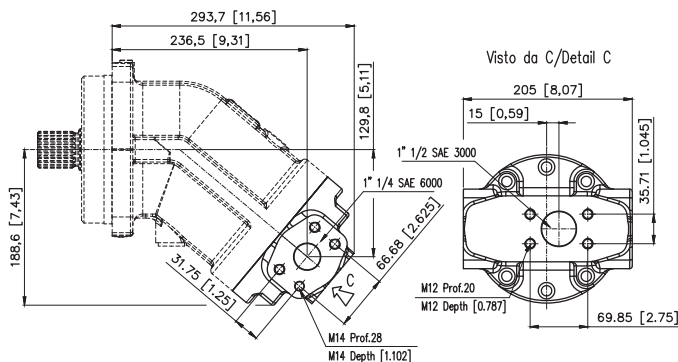

CBQ *Albero cilindrico*
Parallel keyed shaft

CAX *Albero cilindrico*
Parallel keyed shaft

SAP *Albero scanalato*
Splined shaft

SAR *Albero scanalato*
Splined shaft

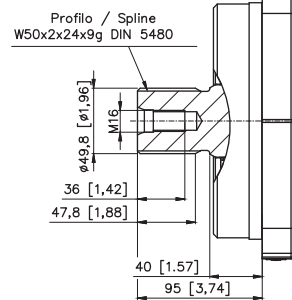
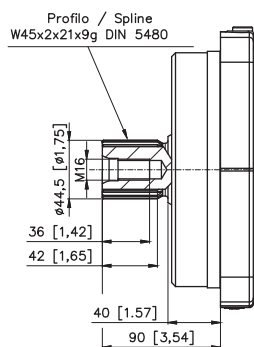
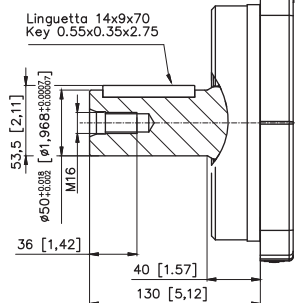
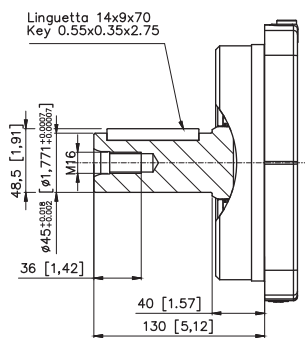

S1, S2: Drenaggi (1 tappato) / Drain ports (1 plugged) - 3/4"-16 UNF 2B
A, B: Utenze / Service line ports
R: Spurgo (tappato) / Air bleed (plugged) - 7/16"-20 UNF 2B

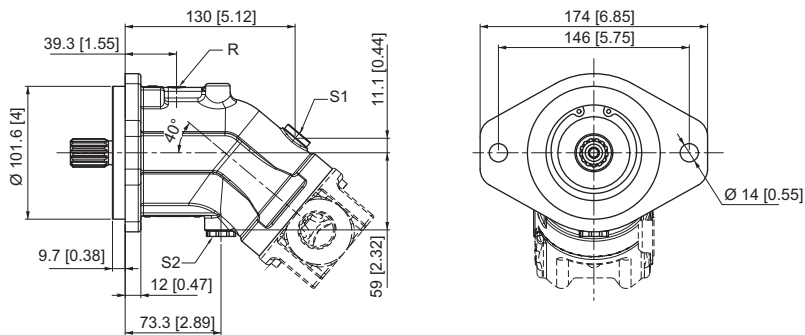

FP2

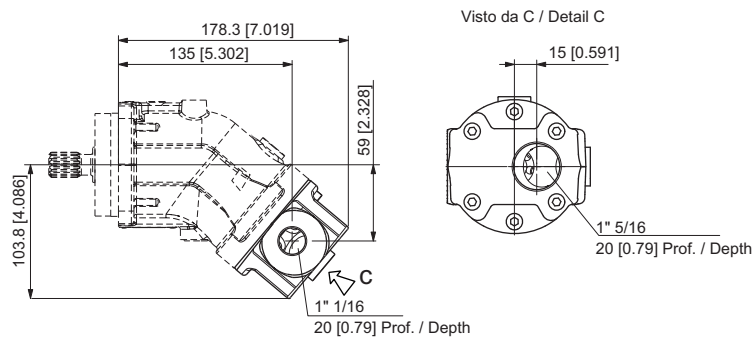

S05 **Albero scanalato**
Splined shaft

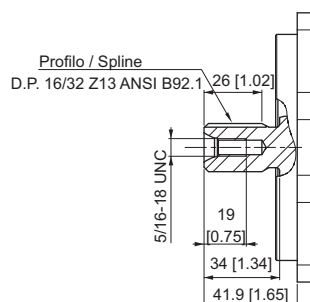

S1, S2: Drenaggi (1 tappato) / Drain ports (1 plugged) - 3/4"-16 UNF 2B
 A, B: Utenze / Service line ports
 R: Spurgo (tappato) / Air bleed (plugged) - 7/16"-20 UNF 2B

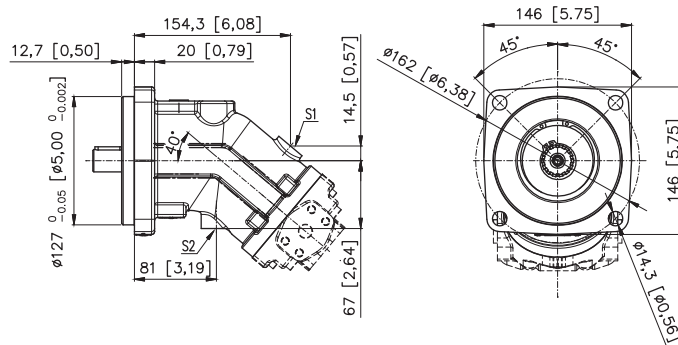

FP2

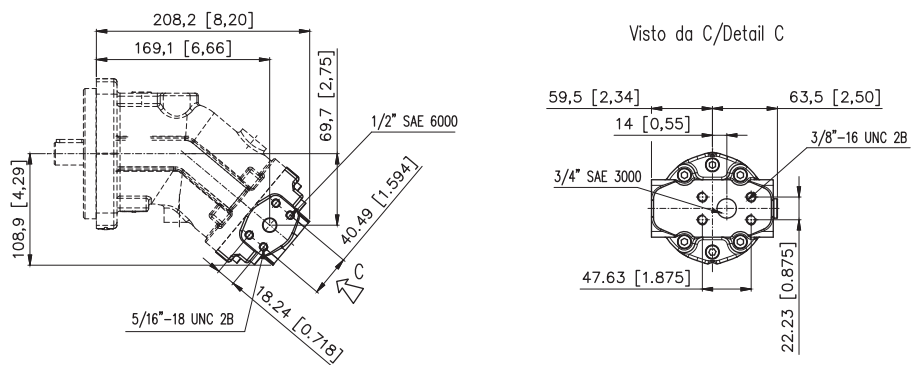

C16 *Albero cilindrico*
Parallel keyed shaft

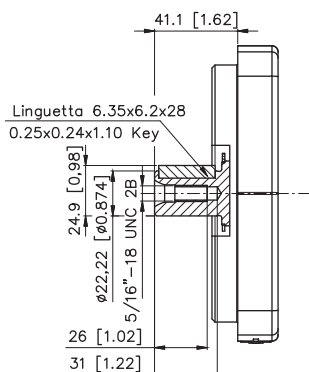

S12 *Albero scanalato*
Splined shaft

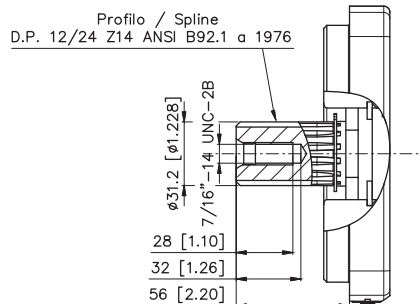

S05 *Albero scanalato*
Splined shaft

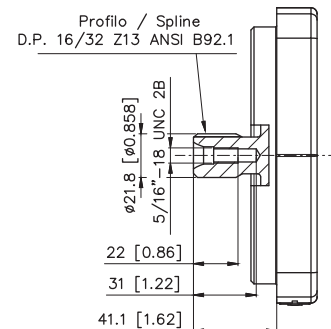

S1, S2: Drenaggi (1 tappato) / Drain ports (1 plugged) - 1" 1/16-12 UN 2B
A, B: Utenze / Service line ports
R: Spurgo (tappato) / Air bleed (plugged) - 7/16"-20 UNF

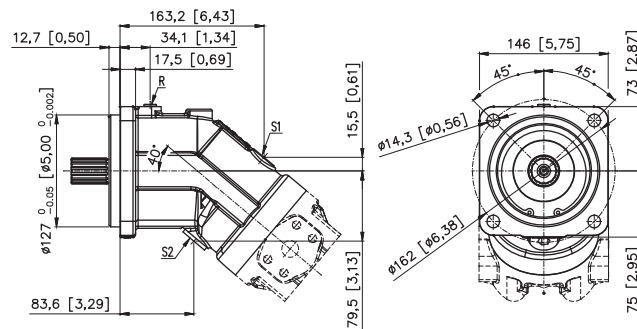

FP2

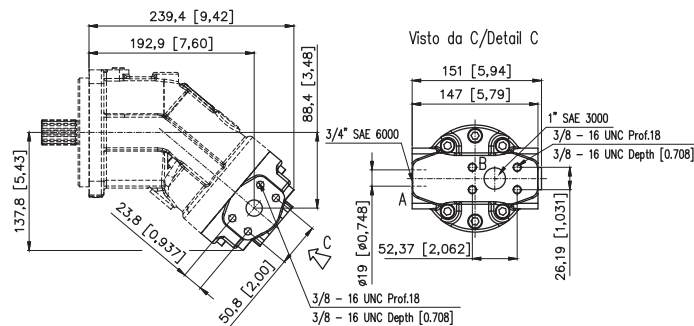

C17 *Albero cilindrico*
Parallel keyed shaft

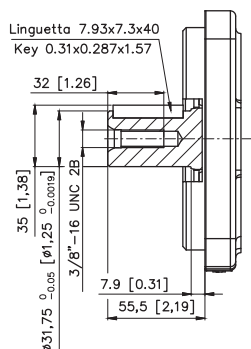

S12 *Albero scanalato*
Splined shaft

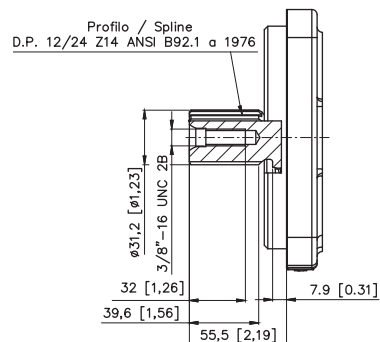

S1, S2: Drenaggi (1 tappato) / Drain ports (1 plugged) - 1" 1/16-12 UN 2B

A, B: Utenze / Service line ports

R: Spurgo (tappato) / Air bleed (plugged) - 7/16"-20 UNF

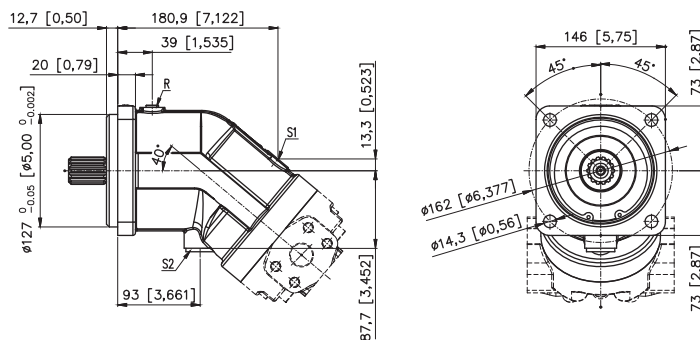

FP2

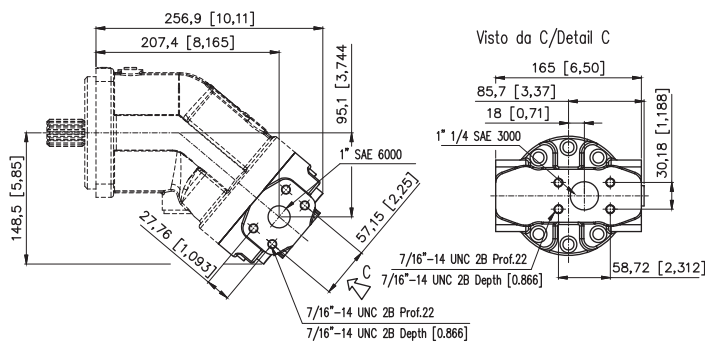

S12 *Albero scanalato*
Splined shaft

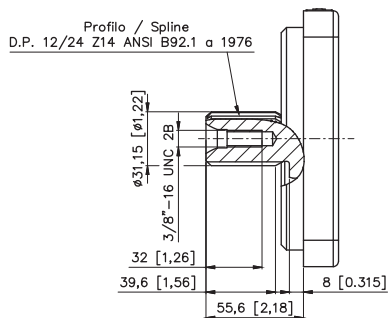

S1, S2: Drenaggi (1 tappato) / Drain ports (1 plugged) - 1" 1/16-12 UN 2B
A, B: UtENZE / Service line ports
R: Spurgo (tappato) / Air bleed (plugged) - 7/16"-20 UNF

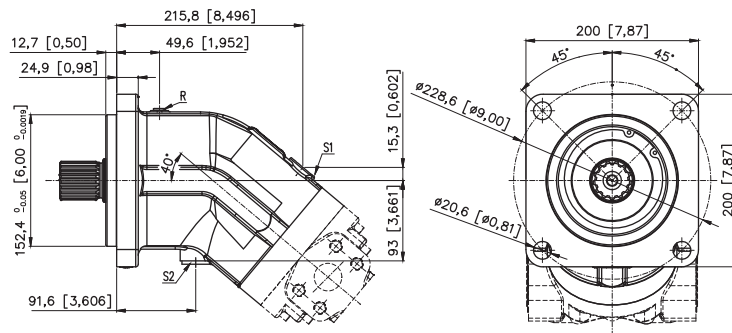

FP2

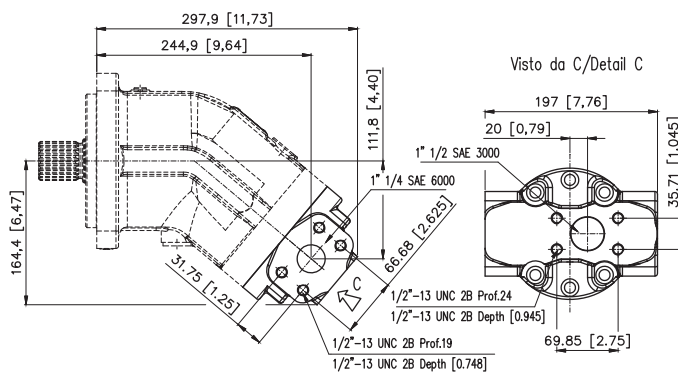

C18 *Albero cilindrico*
Parallel keyed shaft

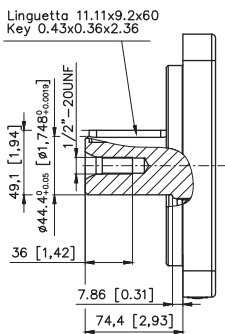

S15 *Albero scanalato*
Splined shaft

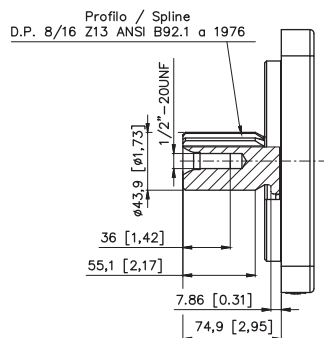

S16 *Albero scanalato*
Splined shaft

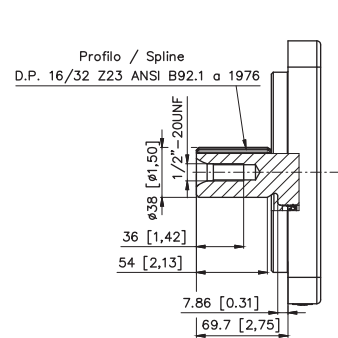

S1, S2: Drenaggi (1 tappato) / Drain ports (1 plugged) - 1" 1/16-12 UN 2B

A, B: Utenze / Service line ports

R: Spurgo (tappato) / Air bleed (plugged) - 7/16"-20 UNF

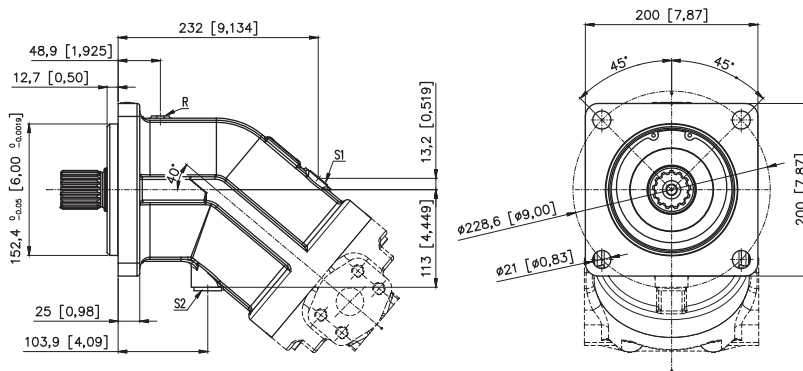

FP2

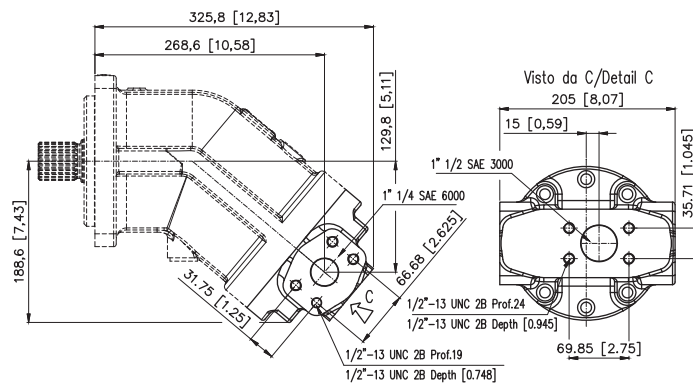

C18 *Albero cilindrico*
Parallel keyed shaft

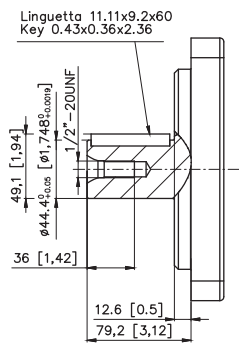

S15 *Albero scanalato*
Splined shaft

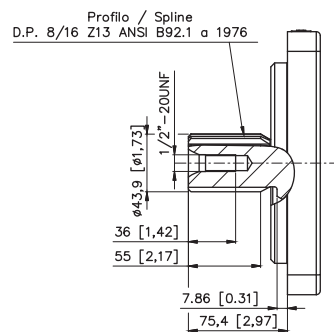

TAPPI DRENAGGIO INVERTITI DRAIN PLUGS REVERSED

Per la serie SH11C è possibile richiedere la posizione dei tappi del drenaggio invertita rispetto allo Standard. Se si vuole predisporre in questa configurazione è necessario specificare in fase d'ordine la caratteristica "RD" (vedere punto 13 del codice di ordinazione).

For the SH11C is possible to request the drain plug reversed compared to standard. If it is necessary in this configuration, to specify in the purchase order the value "RD" (See position 13 of ordering code).

VERSIONE STANDARD STANDARD VERSION

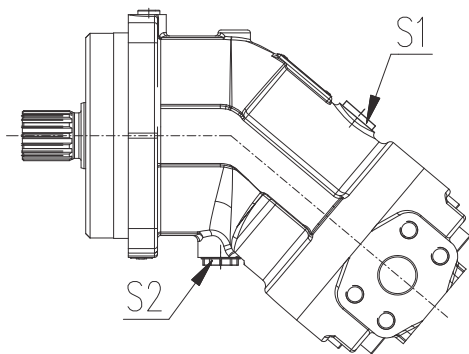

S1 - Tappo in metallo / Metallic plug.
S2 - Tappo in plastica / Plastic plug.

VERSIONE "RD" "RD" VERSION

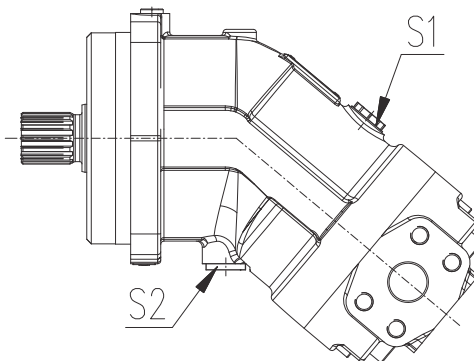

S1 - Tappo in plastica / Plastic plug.
S2 - Tappo in metallo / Metallic plug.

