

MR-J4-GF/MR-J4-GF-RJ Connections with Peripheral Equipment (Note 1)

GF **GF-RJ**

Peripheral equipment is connected to MR-J4-GF/MR-J4-GF-RJ as described below. Connectors, cables, options, and other necessary equipment are available so that users can set up the servo amplifier easily and start using it right away.

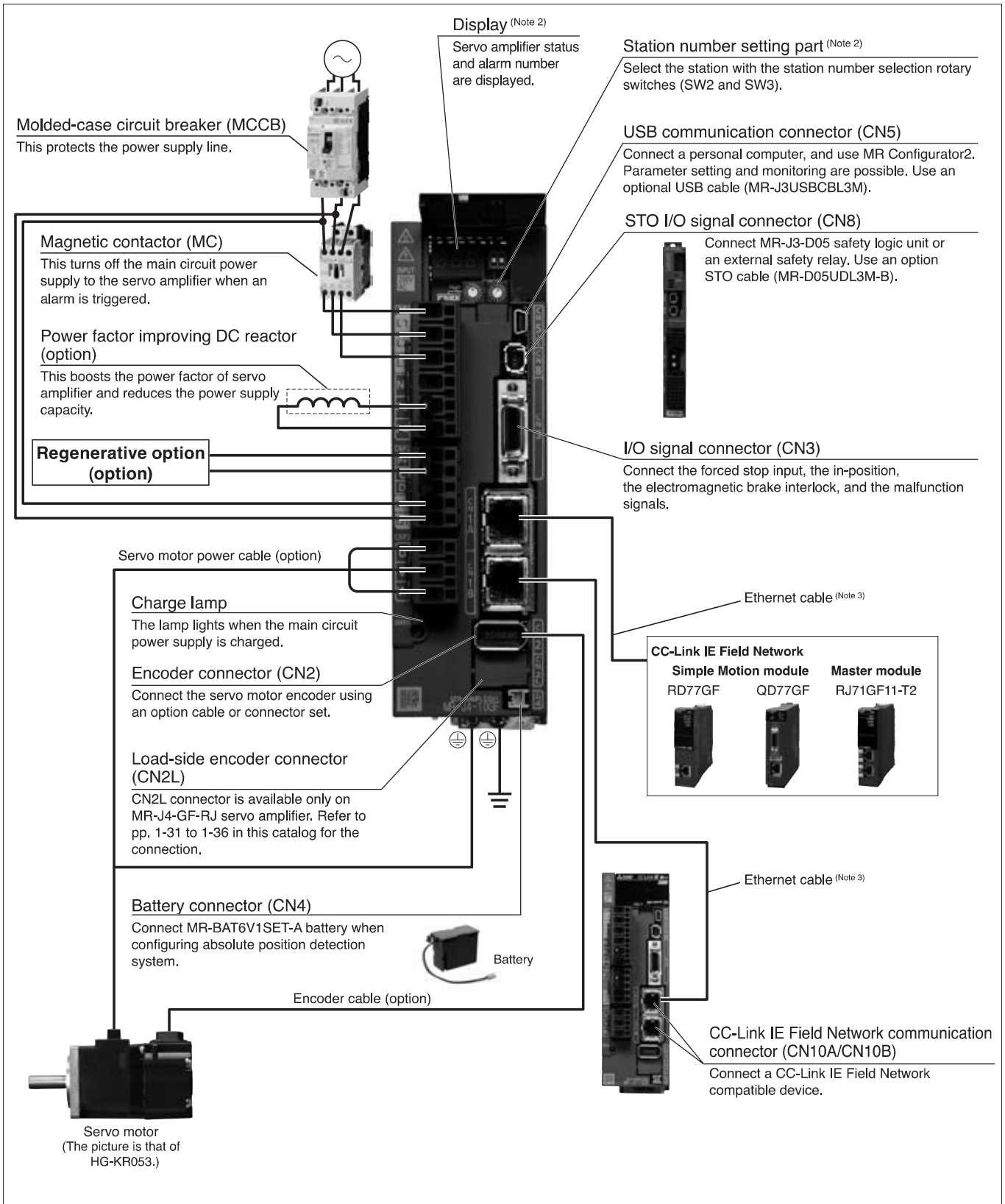

Notes: 1. The connection with the peripheral equipment is an example for MR-J4-350GF/MR-J4-350GF-RJ or smaller servo amplifiers. Refer to "MR-J4-_GF_(-RJ) Servo Amplifier Instruction Manual (Motion Mode)" for the actual connections.
2. This picture shows when the display cover is open.
3. For specifications of the Ethernet cable, refer to "Ethernet Cable Specifications" on p. 5-31 in this catalog.

Servo Amplifiers
Rotary Servo Motors
Linear Servo Motors
Direct Drive Motors
Options/Peripheral Equipment
LV/S/Wires
Product List
Cautions

Servo Amplifiers

MR-J4-GF(1)/MR-J4-GF(1)-RJ

GF GF-RJ

(CC-Link IE Field Network Interface (Note 20) Specifications (200 V/100 V)

Servo amplifier model MR-J4-_(-RJ)		10GF	20GF	40GF	60GF	70GF	100GF	200GF	350GF	500GF	700GF	11KGF	15KGF	22KGF	10GF1	20GF1	40GF1	
Output	Rated voltage	3-phase 170 V AC																
	Rated current [A]	1.1	1.5	2.8	3.2	5.8	6.0	11.0	17.0	28.0	37.0	68.0	87.0	126.0	1.1	1.5	2.8	
Main circuit power supply input	Voltage/frequency (Note 1)	AC input	3-phase or 1-phase 200 V AC to 240 V AC, 50 Hz/60 Hz					3-phase or 1-phase 200 V AC to 240 V AC, 50 Hz/60 Hz (Note 10)		3-phase 200 V AC to 240 V AC, 50 Hz/60 Hz						1-phase 100 V AC to 120 V AC, 50 Hz/60 Hz		
		DC input (Note 12)	283 V DC to 340 V DC															
	Rated current (Note 9) [A]	0.9	1.5	2.6	3.2 (Note 8)	3.8	5.0	10.5	16.0	21.7	28.9	46.0	64.0	95.0	3.0	5.0	9.0	
	Permissible voltage fluctuation	AC input	3-phase or 1-phase 170 V AC to 264 V AC					3-phase or 1-phase 170 V AC to 264 V AC (Note 10)		3-phase 170 V AC to 264 V AC						1-phase 85 V AC to 132 V AC		
		DC input (Note 12)	241 V DC to 374 V DC															
Permissible frequency fluctuation		±5% maximum																
Control circuit power supply input	Voltage/frequency	AC input	1-phase 200 V AC to 240 V AC, 50 Hz/60 Hz													1-phase 100 V AC to 120 V AC, 50 Hz/60 Hz		
		DC input (Note 12)	283 V DC to 340 V DC															
	Rated current [A]	0.2						0.3						0.4				
	Permissible voltage fluctuation	AC input	1-phase 170 V AC to 264 V AC													1-phase 85 V AC to 132 V AC		
		DC input (Note 12)	241 V DC to 374 V DC															
Permissible frequency fluctuation		±5% maximum																
Power consumption [W]		30						45						30				
Interface power supply		24 V DC ± 10% (required current capacity: 0.3 A (including CN8 connector signals))																
Control method		Sine-wave PWM control/current control method																
Permissible regenerative power	Built-in regenerative resistor (Note 2, 3) [W]	-	10	10	10	20	20	100	100	130	170	-	-	-	-	10	10	
	External regenerative resistor (standard accessory) (Note 2, 3, 15, 16) [W]	-	-	-	-	-	-	-	-	-	-	500 (800)	850 (1300)	850 (1300)	-	-	-	
Dynamic brake (Note 4)		Built-in									External option (Note 17)			Built-in				
CC-Link IE Field communication cycle (Note 14)		0.5 ms, 1.0 ms, 2.0 ms, 4.0 ms																
Communication function	USB	Connect a personal computer (MR Configurator2 compatible)																
Encoder output pulse		Compatible (A/B/Z-phase pulse)																
Analog monitor		2 channels																
Positioning mode (Note 18)		Point table method, indexer method																
Fully closed loop control	MR-J4-GF(1)	Two-wire type communication method																
	MR-J4-GF(1)-RJ	Two-wire/four-wire type communication method																
Load-side encoder interface	MR-J4-GF(1)	Mitsubishi Electric high-speed serial communication																
	MR-J4-GF(1)-RJ	Mitsubishi Electric high-speed serial communication, A/B/Z-phase differential input signal																
Servo functions		Advanced vibration suppression control II, adaptive filter II, robust filter, auto tuning, one-touch tuning, tough drive function, drive recorder function, machine diagnosis function (including failure prediction (Note 19)), power monitoring function, scale measurement function, super trace control, lost motion compensation function																
Protective functions		Overcurrent shut-off, regenerative overvoltage shut-off, overload shut-off (electronic thermal), servo motor overheat protection, encoder error protection, regenerative error protection, undervoltage protection, instantaneous power failure protection, overspeed protection, error excessive protection, magnetic pole detection protection, linear servo control fault protection																

MR-J4-GF(1)/MR-J4-GF(1)-RJ

GF GF-RJ

(CC-Link IE Field Network Interface ^(Note 20) Specifications (200 V/100 V)

Servo amplifier model MR-J4-(-RJ)		10GF	20GF	40GF	60GF	70GF	100GF	200GF	350GF	500GF	700GF	11KGF	15KGF	22KGF	10GF1	20GF1	40GF1
Functional safety		STO (IEC/EN 61800-5-2)															
Safety performance	Standards certified by CB ^(Note 13)	EN ISO 13849-1 Category 3 PL e, IEC 61508 SIL 3, EN 62061 SIL CL 3, EN 61800-5-2															
	Response performance	8 ms or less (STO input OFF → energy shut-off)															
	Test pulse input (STO) ^(Note 7)	Test pulse interval: 1 Hz to 25 Hz, test pulse off time: 1 ms maximum															
	Mean time to dangerous failure (MTTFd)	MTTFd ≥ 100 [years] (314a)															
	Diagnostic coverage (DC)	DC = Medium, 97.6 [%]															
	Probability of dangerous Failure per Hour (PFH)	PFH = 6.4 × 10 ⁻⁹ [1/h]															
Compliance with global standards		Refer to "Compliance with Global Standards and Regulations" on p. 55 in this catalog.															
Structure (IP rating)		Natural cooling, open (IP20)				Force cooling, open (IP20)				Force cooling, open (IP20) ^(Note 5)				Natural cooling, open (IP20)			
Close mounting	3-phase power input	Possible ^(Note 6)						Not possible						-			
	1-phase power input	Possible ^(Note 6)				Not possible		-				Possible ^(Note 6)					
Environment	Ambient temperature	Operation: 0 °C to 55 °C (non-freezing), storage: -20 °C to 65 °C (non-freezing)															
	Ambient humidity	Operation/storage: 5 %RH to 90 %RH (non-condensing)															
	Ambience	Indoors (no direct sunlight); no corrosive gas, inflammable gas, oil mist or dust															
	Altitude	2000 m or less above sea level ^(Note 11)															
Vibration resistance		5.9 m/s ² at 10 Hz to 55 Hz (directions of X, Y, and Z axes)															
Mass [kg]		1.0	1.0	1.0	1.0	1.4	1.4	2.1	2.3	4.0	6.2	13.4	13.4	18.2	1.0	1.0	1.0

- Notes: 1. Rated output and speed of a rotary servo motor and a direct drive motor; and continuous thrust and maximum speed of a linear servo motor are applicable when the servo amplifier is operated within the specified power supply voltage and frequency.
 2. Select the most suitable regenerative option for your system with our capacity selection software.
 3. Refer to "Regenerative Option" in this catalog for the permissible regenerative power [W] when a regenerative option is used.
 4. When using the dynamic brake, refer to "MR-J4-_GF_(-RJ) Servo Amplifier Instruction Manual (Motion Mode)" for the permissible load to motor inertia ratio and the permissible load to mass ratio.
 5. Terminal blocks are excluded.
 6. When the servo amplifiers are closely mounted, keep the ambient temperature within 0 °C to 45 °C, or use the servo amplifiers at 75% or less of the effective load ratio.
 7. The test pulse is a signal for the external circuit to perform self-diagnosis by turning off the signals to the servo amplifier instantaneously at regular intervals.
 8. The rated current is 2.9 A when the servo amplifier is used with UL or CSA compliant servo motor.
 9. This value is applicable when a 3-phase power supply is used.
 10. When a 1-phase 200 V AC to 240 V AC power supply is used, use the servo amplifiers at 75% or less of the effective load ratio.
 11. Refer to "MR-J4-_GF_(-RJ) Servo Amplifier Instruction Manual (Motion Mode)" for the restrictions when using the servo amplifiers at altitude exceeding 1000 m and up to 2000 m above sea level.
 12. DC power input is supported by MR-J4-_GF-RJ. For a connection example of power supply circuit with DC input, refer to "MR-J4-_GF_(-RJ) Servo Amplifier Instruction Manual (Motion Mode)".
 13. The safety level depends on the setting value of [Pr. PF18 STO diagnosis error detection time] and whether or not STO input diagnosis is performed by TOFB output. Refer to "MR-J4-_GF_(-RJ) Servo Amplifier Instruction Manual (Motion Mode)" for details.
 14. The command communication cycle depends on the controller specifications and the number of axes connected.
 15. The value in brackets is applicable when cooling fans (two units of 92 mm × 92 mm, minimum air flow: 1.0 m³/min) are installed, and then [Pr. PA02] is changed.
 16. Servo amplifiers without an enclosed regenerative resistor are also available. Refer to "Model Designation for 1-Axis Servo Amplifier" in this catalog for details.
 17. Use an external dynamic brake (option) with the servo amplifier. Without the external dynamic brake, a servo motor does not stop immediately at emergency stop and falls in free-run status, causing an accident such as machine collision, etc. Take measures to ensure safety on the entire system when not using the dynamic brake.
 18. Positioning mode is supported by MR-J4-_GF(-RJ) servo amplifiers with software version B3 or later.
 19. The failure prediction function is supported by MR-J4-_GF(-RJ) servo amplifiers with software version A3 or later.
 20. These models also support CC-Link IE Field Network Basic. To use this network, switch the network setting with the slide switches. Refer to "MR-J4-_GF_(-RJ) Servo Amplifier Instruction Manual (CC-Link IE Field Network Basic)" for CC-Link IE Field Network Basic.

Servo Amplifiers

Rotary Servo Motors

Linear Servo Motors

Direct Drive Motors

Options/Peripheral Equipment

LVS/Wires

Product List

Cautions

MR-J4-GF4/MR-J4-GF4-RJ

GF GF-RJ

(CC-Link IE Field Network Interface) Specifications (400 V)

Servo amplifier model MR-J4-_-(-RJ)		60GF4	100GF4	200GF4	350GF4	500GF4	700GF4	11KGF4	15KGF4	22KGF4	
Output	Rated voltage	3-phase 323 V AC									
	Rated current [A]	1.5	2.8	5.4	8.6	14.0	17.0	32.0	41.0	63.0	
Main circuit power supply input	Voltage/frequency ^(Note 1)	3-phase 380 V AC to 480 V AC, 50 Hz/60 Hz									
	Rated current [A]	1.4	2.5	5.1	7.9	10.8	14.4	23.1	31.8	47.6	
	Permissible voltage fluctuation	3-phase 323 V AC to 528 V AC									
	Permissible frequency fluctuation	±5% maximum									
Control circuit power supply input	Voltage/frequency	1-phase 380 V AC to 480 V AC, 50 Hz/60 Hz									
	Rated current [A]	0.1				0.2					
	Permissible voltage fluctuation	1-phase 323 V AC to 528 V AC									
	Permissible frequency fluctuation	±5% maximum									
	Power consumption [W]	30				45					
Interface power supply		24 V DC ± 10% (required current capacity: 0.3 A (including CN8 connector signals))									
Control method		Sine-wave PWM control/current control method									
Permissible regenerative power	Built-in regenerative resistor ^(Note 2, 3) [W]	15	15	100	100	130 ^(Note 7)	170 ^(Note 7)	-	-	-	
	External regenerative resistor (standard accessory) ^(Note 2, 3, 12, 13) [W]	-	-	-	-	-	-	500 (800)	850 (1300)	850 (1300)	
Dynamic brake ^(Note 4)		Built-in					External option ^(Note 11)				
CC-Link IE Field communication cycle ^(Note 10)		0.5 ms, 1.0 ms, 2.0 ms, 4.0 ms									
Communication function USB		Connect a personal computer (MR Configurator2 compatible)									
Encoder output pulse		Compatible (A/B/Z-phase pulse)									
Analog monitor		2 channels									
Positioning mode		Point table method, indexer method									
Fully closed loop control	MR-J4-GF4	Two-wire type communication method									
	MR-J4-GF4-RJ	Two-wire/four-wire type communication method									
Load-side encoder interface	MR-J4-GF4	Mitsubishi Electric high-speed serial communication									
	MR-J4-GF4-RJ	Mitsubishi Electric high-speed serial communication, A/B/Z-phase differential input signal									
Servo functions		Advanced vibration suppression control II, adaptive filter II, robust filter, auto tuning, one-touch tuning, tough drive function, drive recorder function, machine diagnosis function (including failure prediction ^(Note 15)), power monitoring function, scale measurement function, super trace control, lost motion compensation function									
Protective functions		Overcurrent shut-off, regenerative overvoltage shut-off, overload shut-off (electronic thermal), servo motor overheat protection, encoder error protection, regenerative error protection, undervoltage protection, instantaneous power failure protection, overspeed protection, error excessive protection, magnetic pole detection protection, linear servo control fault protection									
Functional safety		STO (IEC/EN 61800-5-2)									
Safety performance	Standards certified by CB ^(Note 9)	EN ISO 13849-1 Category 3 PL e, IEC 61508 SIL 3, EN 62061 SIL CL 3, EN 61800-5-2									
	Response performance	8 ms or less (STO input OFF → energy shut-off)									
	Test pulse input (STO) ^(Note 6)	Test pulse interval: 1 Hz to 25 Hz, test pulse off time: 1 ms maximum									
	Mean time to dangerous failure (MTTFd)	MTTFd ≥ 100 [years] (314a)									
	Diagnostic coverage (DC)	DC = Medium, 97.6 [%]									
	Probability of dangerous Failure per Hour (PFH)	PFH = 6.4 × 10 ⁻⁹ [1/h]									
Compliance with global standards		Refer to "Compliance with Global Standards and Regulations" on p. 55 in this catalog.									
Structure (IP rating)		Natural cooling, open (IP20)	Force cooling, open (IP20)			Force cooling, open (IP20) ^(Note 5)					
Close mounting		Not possible									
Environment	Ambient temperature	Operation: 0 °C to 55 °C (non-freezing), storage: -20 °C to 65 °C (non-freezing)									
	Ambient humidity	Operation/storage: 5 %RH to 90 %RH (non-condensing)									
	Ambience	Indoors (no direct sunlight); no corrosive gas, inflammable gas, oil mist or dust									
	Altitude	2000 m or less above sea level ^(Note 8)									
	Vibration resistance	5.9 m/s ² at 10 Hz to 55 Hz (directions of X, Y, and Z axes)									
Mass [kg]		1.7	1.7	2.1	3.6	4.3	6.5	13.4	13.4	18.2	

MR-J4-GF4/MR-J4-GF4-RJ

GF GF-RJ

(CC-Link IE Field Network Interface) Specifications (400 V)

- Notes: 1. Rated output and speed of a rotary servo motor, and continuous thrust and maximum speed of a linear servo motor are applicable when the servo amplifier is operated within the specified power supply voltage and frequency.
2. Select the most suitable regenerative option for your system with our capacity selection software.
3. Refer to "Regenerative Option" in this catalog for the permissible regenerative power [W] when a regenerative option is used.
4. When using the dynamic brake, refer to "MR-J4-_GF_(-RJ) Servo Amplifier Instruction Manual (Motion Mode)" for the permissible load to motor inertia ratio and the permissible load to mass ratio.
5. Terminal blocks are excluded.
6. The test pulse is a signal for the external circuit to perform self-diagnosis by turning off the signals to the servo amplifier instantaneously at regular intervals.
7. The servo amplifier built-in regenerative resistor is compatible with the maximum torque deceleration when the servo motor is used within the rated speed and the recommended load to motor inertia ratio. Contact your local sales office if the operating motor speed or the load to motor inertia ratio exceeds the rated speed or the recommended ratio.
8. Refer to "MR-J4-_GF_(-RJ) Servo Amplifier Instruction Manual (Motion Mode)" for the restrictions when using the servo amplifiers at altitude exceeding 1000 m and up to 2000 m above sea level.
9. The safety level depends on the setting value of [Pr. PF18 STO diagnosis error detection time] and whether or not STO input diagnosis is performed by TOFB output. Refer to "MR-J4-_GF_(-RJ) Servo Amplifier Instruction Manual (Motion Mode)" for details.
10. The command communication cycle depends on the controller specifications and the number of axes connected.
11. Use an external dynamic brake (option) with the servo amplifier. Without the external dynamic brake, a servo motor does not stop immediately at emergency stop and falls in free-run status, causing an accident such as machine collision, etc. Take measures to ensure safety on the entire system when not using the dynamic brake.
12. The value in brackets is applicable when cooling fans (two units of 92 mm × 92 mm, minimum air flow: 1.0 m³/min) are installed, and then [Pr. PA02] is changed.
13. Servo amplifiers without an enclosed regenerative resistor are also available. Refer to "Model Designation for 1-Axis Servo Amplifier" in this catalog for details.
14. Positioning mode is supported by MR-J4-_GF4(-RJ) servo amplifiers with software version B3 or later.
15. The failure prediction function is supported by MR-J4-_GF4(-RJ) servo amplifiers with software version A3 or later.

Servo Amplifiers

Rotary Servo Motors

Linear Servo Motors

Direct Drive Motors

Options/Peripheral Equipment

LVS/Wires

Product List

Cautions

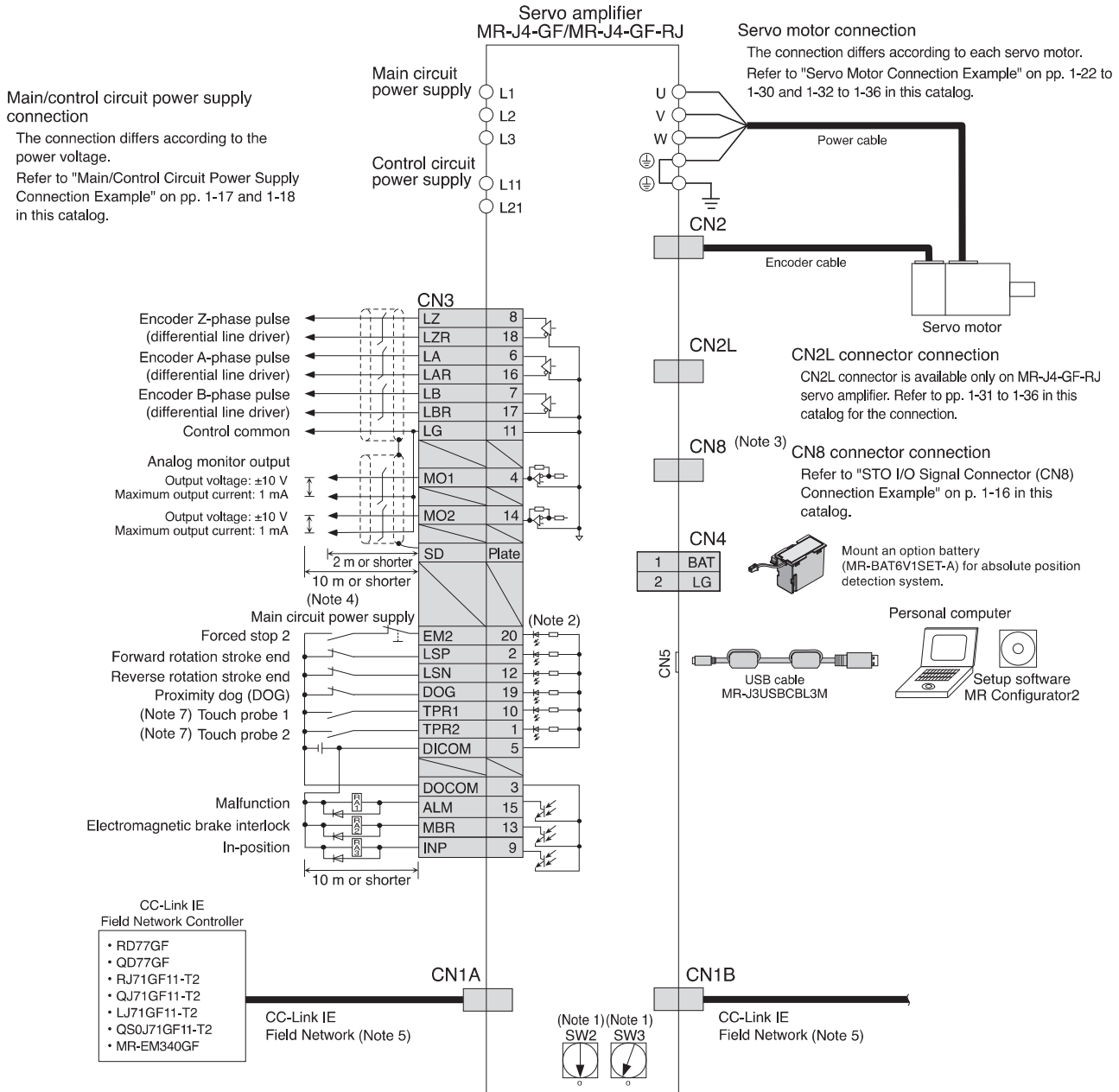

- Notes: 1. Up to 120 stations are set with a combination of the station number selection rotary switches (SW2 and SW3). Note that the number of the connectable stations depends on the controller specifications.
2. This is for sink wiring. Source wiring is also possible.
3. Be sure to attach a short-circuit connector supplied with the servo amplifier when the STO function is not used.
4. To prevent an unexpected restart of the servo amplifier, create a circuit to turn off EM2 (Forced stop 2) when the main circuit power is turned off.
5. When branching off CC-Link IE Field Network (synchronous communication function) with a switching hub, use N22MHG-T8F2 (Mitsubishi Electric Corporation) or DT135TX (Mitsubishi Electric System & Service Co., Ltd.).
6. This standard wiring diagram is common for 200 V AC and 400 V AC type servo amplifiers. The connection is the same for positioning mode.
7. TPR1 (touch probe 1) and TPR2 (touch probe 2) are available only with MR-J4-GF-RJ.



Be sure to read through Instruction Manual for the actual wiring and use. Use the equipment after you have a full knowledge of the equipment, safety information and instructions.

STO I/O Signal Connector (CN8) Connection Example

GF GF-RJ B B-RJ WB A A-RJ

●When used with MR-J3-D05

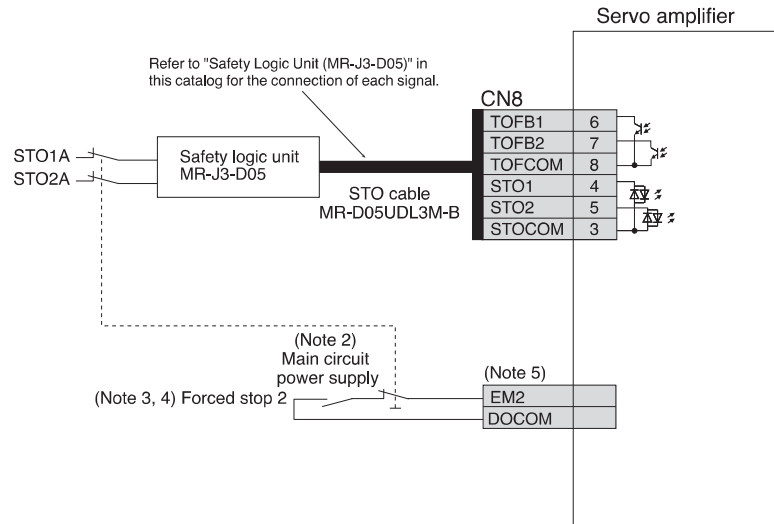

●When using a safety door

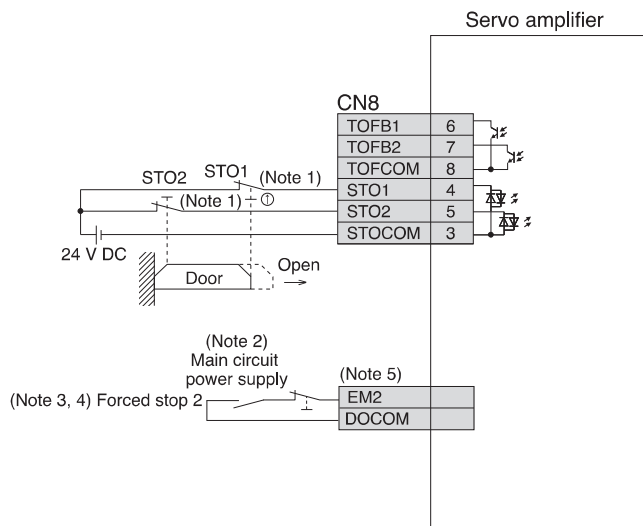

- Notes: 1. When using the STO function, turn off STO1 and STO2 at the same time. Be sure to turn off STO1 and STO2 after the servo motor stops in servo-off state or after the servo motor is forcibly stopped with deceleration by turning off EM2 (Forced stop 2).
2. To prevent an unexpected restart of the servo amplifier, create a circuit to turn off EM2 (Forced stop 2) when the main circuit power is turned off.
3. If the controller does not have a forced stop function, install a forced stop 2 switch (normally closed contact).
4. Turn on EM2 (Forced stop 2) before starting the operation.
5. The connector and the pin numbers for each signal vary depending on the servo amplifier. Refer to the standard wiring diagram example for relevant servo amplifier in this catalog for details.



Be sure to read through Instruction Manual for the actual wiring and use. Use the equipment after you have a full knowledge of the equipment, safety information and instructions.

Servo Amplifiers

Rotary Servo Motors

Linear Servo Motors

Direct Drive Motors

Options/Peripheral Equipment

LV/S/Wires

Product List

Cautions

Servo Amplifiers

Main/Control Circuit Power Supply Connection Example (Note 7)

GF GF-RJ B B-RJ A A-RJ

● For 1-phase 100 V AC

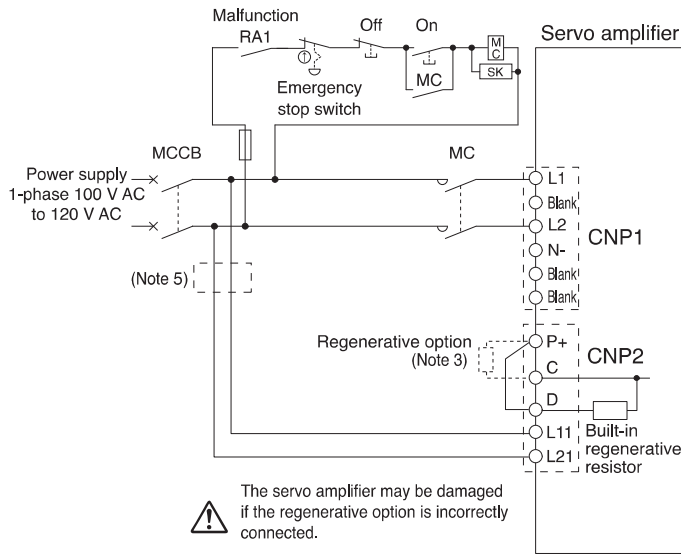

● For 1-phase 200 V AC

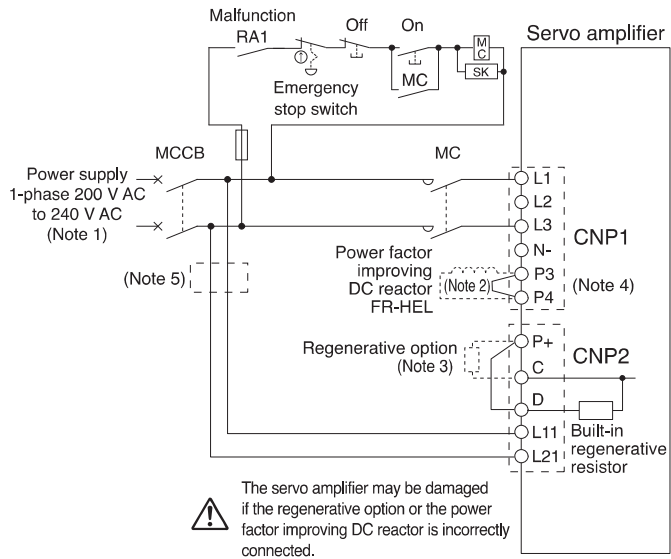

● For 3-phase 200 V AC, 3.5 kW or smaller

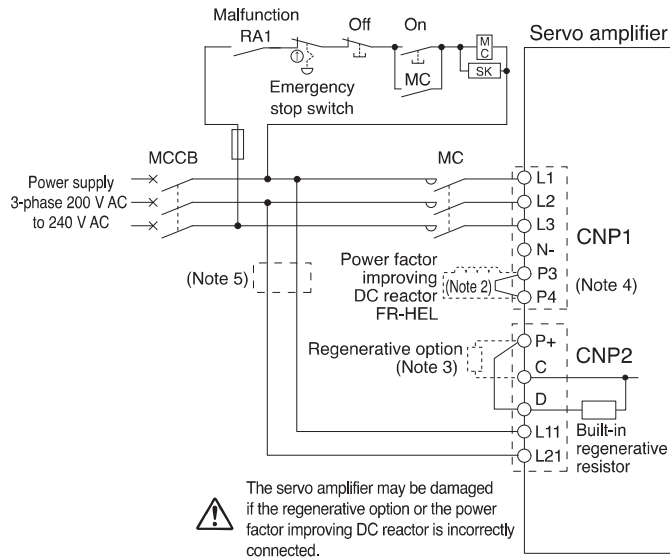

● For 3-phase 400 V AC, 3.5 kW or smaller

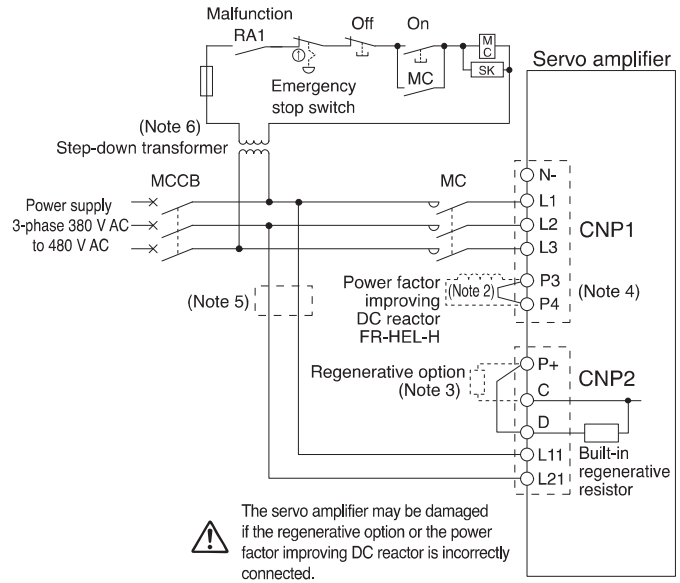

- Notes: 1. For 1-phase 200 V AC to 240 V AC, connect the power supply to L1 and L3 terminals. Do not connect anything to L2. The connections are different from MR-J3 series servo amplifiers. Be careful not to make a connection error when replacing MR-J3 with MR-J4.
2. Disconnect a short-circuit bar between P3 and P4 when using the power factor improving DC reactor.
3. Disconnect a short-circuit bar between P+ and D when connecting the regenerative option externally.
4. MR-J4 series servo amplifiers have P3 and P4 in the upstream of the inrush current suppression circuit. They are different from P1 and P2 (downstream of the inrush current suppression circuit) of MR-J3 series servo amplifiers. Refer to relevant Servo Amplifier Instruction Manual for details.
5. When wires used for L11 and L21 are thinner than those for L1, L2, and L3, use a molded-case circuit breaker or a fuse. Refer to relevant Servo Amplifier Instruction Manual for details.
6. A step-down transformer is required if coil voltage of the magnetic contactor is in 200 V class.
7. To turn on/off the main circuit power supply by a DC power supply, refer to relevant Servo Amplifier Instruction Manual for a connection example of the power supply circuit.



Be sure to read through Instruction Manual for the actual wiring and use. Use the equipment after you have a full knowledge of the equipment, safety information and instructions.

Main/Control Circuit Power Supply Connection Example (Note 9)

GF GF-RJ B B-RJ A A-RJ

● For 3-phase 200 V AC, 5 kW

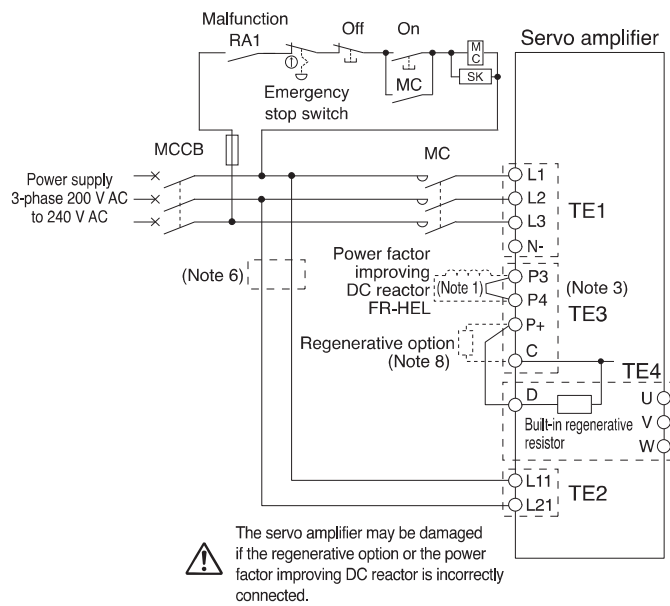

● For 3-phase 400 V AC, 5 kW

● For 3-phase 200 V AC/400 V AC, 7 kW

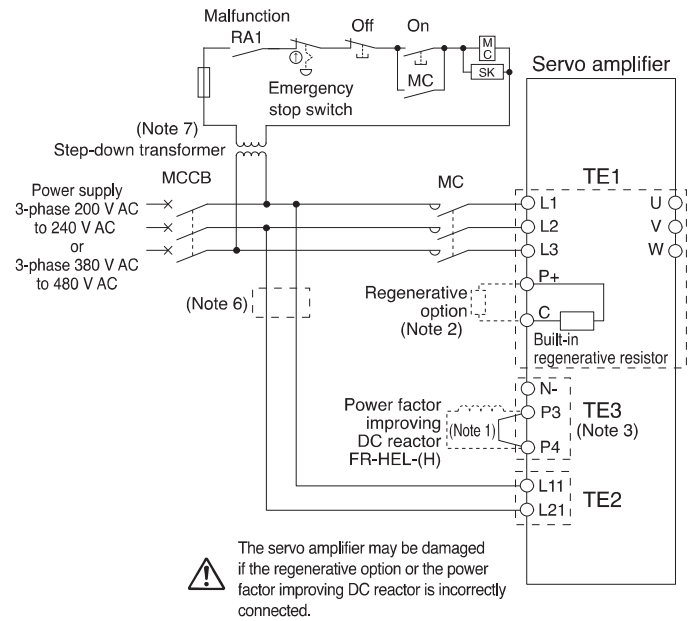

● For 3-phase 200 V AC/400 V AC, 11 kW to 22 kW

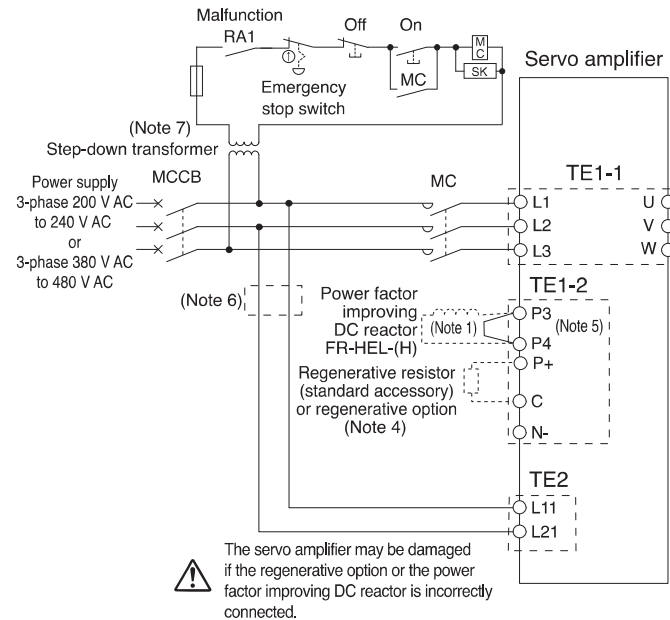

- Notes: 1. Disconnect a short-circuit bar between P3 and P4 when using the power factor improving DC reactor.
 2. Disconnect the wires for the built-in regenerative resistor (P+ and C) when connecting the regenerative option externally.
 3. MR-J4 series servo amplifiers have P3 and P4 in the upstream of the inrush current suppression circuit. They are different from P1 and P2 (downstream of the inrush current suppression circuit) of MR-J3 series servo amplifiers. Refer to relevant Servo Amplifier Instruction Manual for details.
 4. MR-J4-11KGF/_B_/A_ or larger servo amplifiers do not have a built-in regenerative resistor.
 5. MR-J4 series servo amplifiers have P3 and P4 in the upstream of the inrush current suppression circuit. They are different from P1 and P (downstream of the inrush current suppression circuit) of MR-J3 series servo amplifiers. Refer to relevant Servo Amplifier Instruction Manual for details.
 6. When wires used for L11 and L21 are thinner than those for L1, L2, and L3, use a molded-case circuit breaker or a fuse. Refer to relevant Servo Amplifier Instruction Manual for details.
 7. A step-down transformer is required if the servo amplifier is in 400 V class, and coil voltage of the magnetic contactor is in 200 V class.
 8. Disconnect a short-circuit bar between P+ and D when connecting the regenerative option externally.
 9. To turn on/off the main circuit power supply by a DC power supply, refer to relevant Servo Amplifier Instruction Manual for a connection example of the power supply circuit.



Be sure to read through Instruction Manual for the actual wiring and use. Use the equipment after you have a full knowledge of the equipment, safety information and instructions.

Servo Amplifiers
 Rotary Servo Motors
 Linear Servo Motors
 Direct Drive Motors
 Options/Peripheral Equipment
 LV/S/Wires
 Product List
 Cautions

Main/Control Circuit Power Supply Connection Example

B B-RJ

● For connecting MR-CV_ and MR-J4-DU_B(-RJ) (one-axis connection)

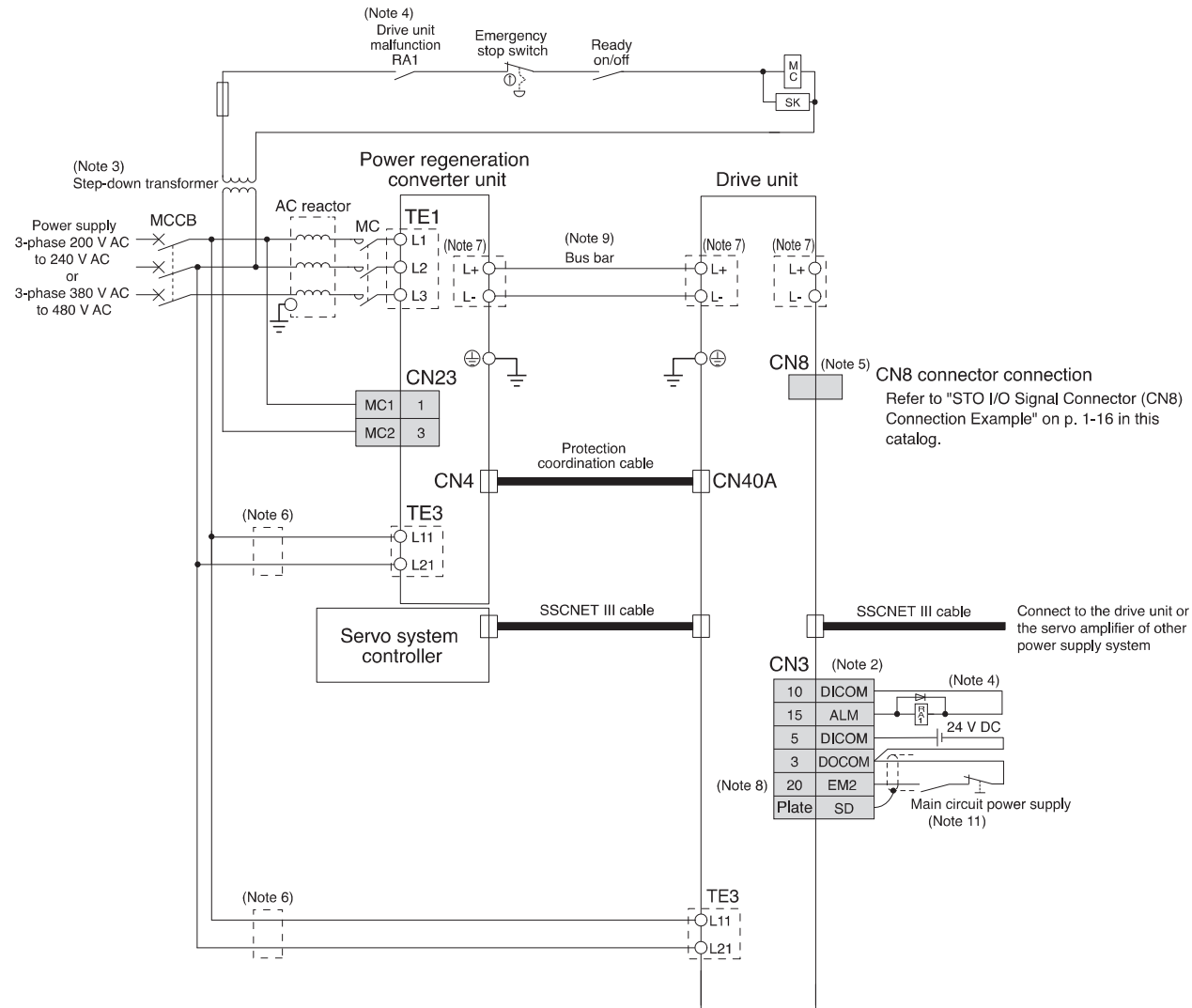

- Notes:
- To prevent an unexpected restart of the drive unit, create a circuit to turn off EM2 (Forced stop 2) when the main circuit power is turned off.
 - This is for sink wiring. Source wiring is also possible.
 - A step-down transformer is required if the power regeneration converter unit is in 400 V class, and coil voltage of the magnetic contactor is in 200 V class.
 - Create a sequence that shuts off the main circuit power when an alarm occurs.
 - Be sure to attach a short-circuit connector supplied with the drive unit when the STO function is not used.
 - Install an overcurrent protection device (molded-case circuit breaker, fuse, etc.) to protect the branch circuit.
 - Terminal varies depending on the capacity of the power regeneration converter unit and the drive unit. Refer to "MR-CV_ Power Regeneration Converter Unit Dimensions" and "MR-J4-DU_B/MR-J4-DU_B-RJ Dimensions" in this catalog.
 - To stop the servo motor by forcibly decelerating with EM2, parameter setting is required. Refer to "MR-CV_ MR-CR55K_ MR-J4-DU_B(-RJ) MR-J4-DU_A(-RJ) Instruction Manual" for details.
 - The bus bar varies depending on the combination of the power regeneration converter unit and the drive unit. Refer to "Bus Bar" in this catalog for details.



Be sure to read through Instruction Manual for the actual wiring and use. Use the equipment after you have a full knowledge of the equipment, safety information and instructions.

Main/Control Circuit Power Supply Connection Example

B B-RJ

● For connecting MR-CV_ and MR-J4-DU_B(-RJ) (multi-axis connection)

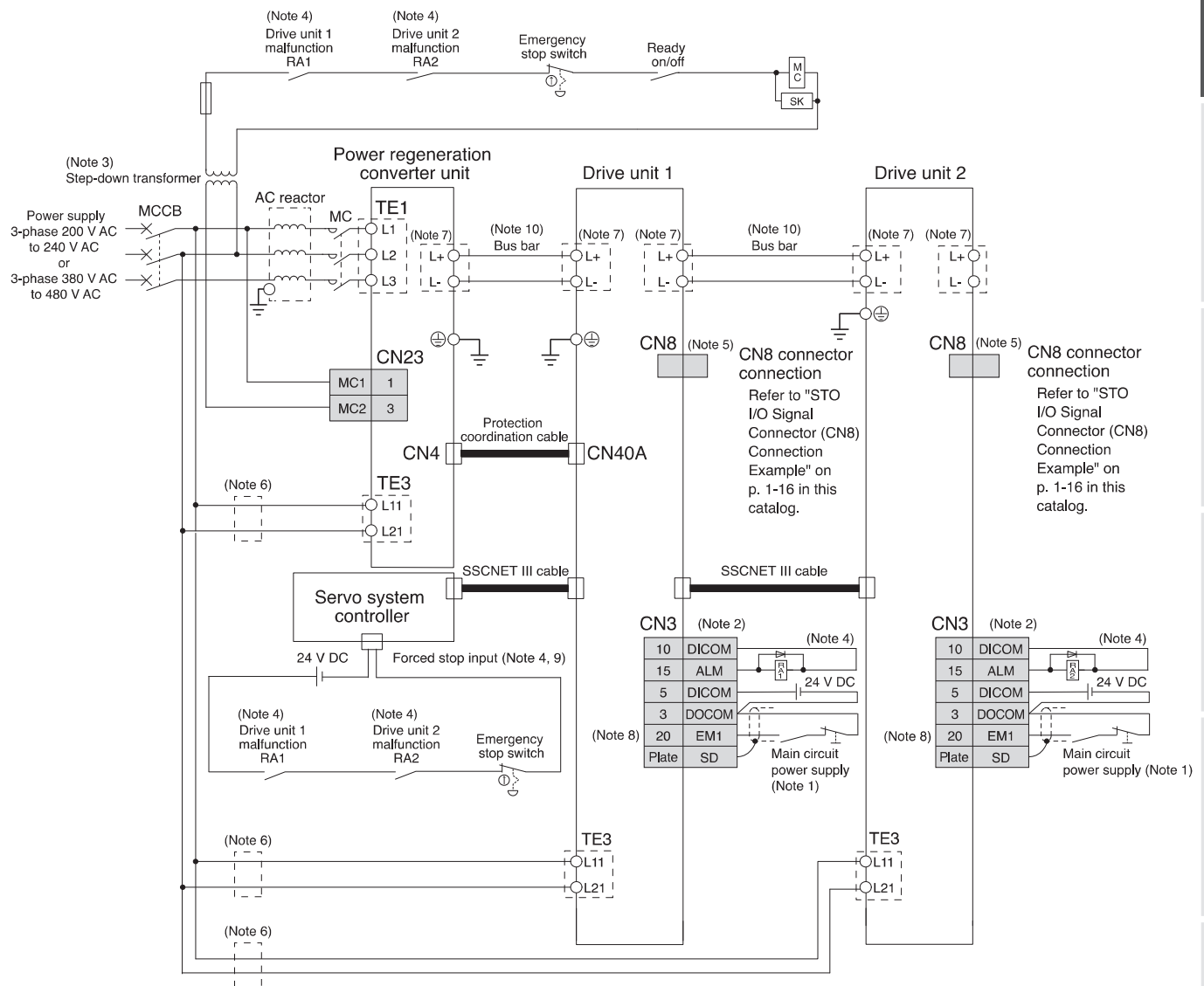

- Notes:
- To prevent an unexpected restart of the drive unit, create a circuit to turn off EM1 (Forced stop 1) when the main circuit power is turned off.
 - This is for sink wiring. Source wiring is also possible.
 - A step-down transformer is required if the power regeneration converter unit is in 400 V class, and coil voltage of the magnetic contactor is in 200 V class.
 - When connecting multiple drive units, create a sequence in which the servo system controller stops all axes and a sequence that shuts off the main circuit power if an alarm occurs on one axis.
 - Be sure to attach a short-circuit connector supplied with the drive unit when the STO function is not used.
 - Install an overcurrent protection device (molded-case circuit breaker, fuse, etc.) to protect the branch circuit.
 - Terminal varies depending on the capacity of the power regeneration converter unit and the drive unit. Refer to "MR-CV_ Power Regeneration Converter Unit Dimensions" and "MR-J4-DU_B/MR-J4-DU_B-RJ Dimensions" in this catalog.
 - To stop the servo motors of all axes forcibly with EM1, parameter setting is required. Refer to "MR-J4_B_(-RJ) Servo Amplifier Instruction Manual" for details.
 - Refer to the controller instruction manuals for the forced stop input of the servo system controller.
 - The bus bar varies depending on the combination of the power regeneration converter unit and the drive unit. Refer to "Bus Bar" in this catalog for details.

! Be sure to read through Instruction Manual for the actual wiring and use. Use the equipment after you have a full knowledge of the equipment, safety information and instructions.

Servo Amplifiers
 Rotary Servo Motors
 Linear Servo Motors
 Direct Drive Motors
 Options/Peripheral Equipment
 LV/S/Wires
 Product List
 Cautions

Main/Control Circuit Power Supply Connection Example (Note 8)

B B-RJ A A-RJ

● For connecting MR-CR_ and MR-J4-DU_B(-RJ)/MR-J4-DU_A(-RJ) (3-phase 200 V AC/400 V AC, 30 kW or larger)

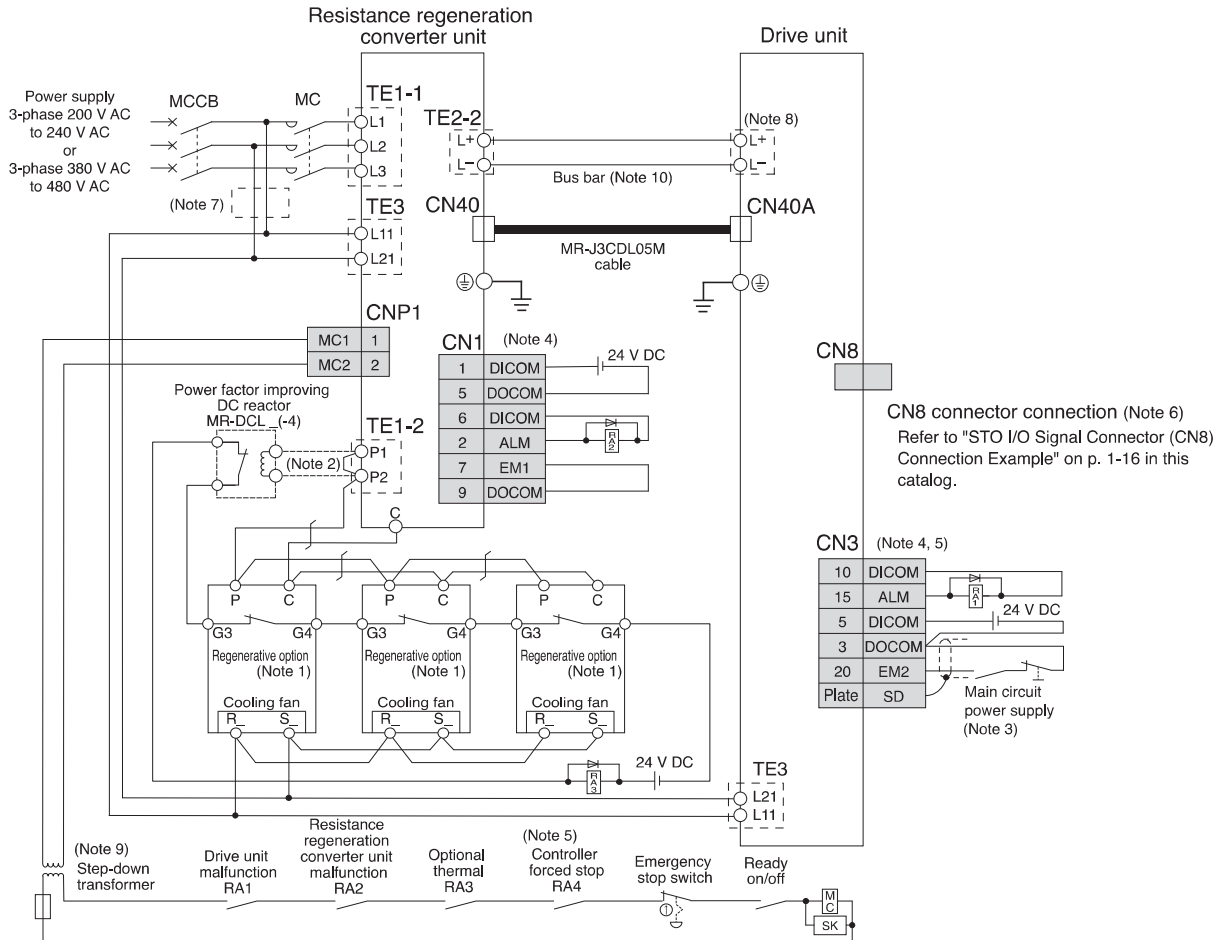

- Notes: 1. This connection is applicable when MR-RB137 (for 200 V) or MR-RB13V-4 (for 400 V) is used. Note that three units of MR-RB137 or MR-RB13V-4 are required for each resistance regeneration converter unit. (Permissible regenerative power: 3900 W)
2. Disconnect a short-circuit bar between P1 and P2 when using the power factor improving DC reactor.
3. To prevent an unexpected restart of the drive unit, create a circuit to turn off EM2 (Forced stop 2) when the main circuit power is turned off.
4. This is for sink wiring. Source wiring is also possible.
5. This connection is applicable for MR-J4-DU_B(-RJ)/MR-J4-DU_B4(-RJ). For MR-J4-DU_A(-RJ)/MR-J4-DU_A4(-RJ), refer to "MR-CV_ MR-CR55K_ MR-J4-DU_B_(-RJ) MR-J4-DU_A_(-RJ) Instruction Manual."
6. Be sure to attach a short-circuit connector supplied with the drive unit when the STO function is not used.
7. Install an overcurrent protection device (molded-case circuit breaker, fuse, etc.) to protect the branch circuit.
8. Terminal varies depending on the drive unit capacities. Refer to the dimensions of the relevant drive unit in this catalog for details.
9. A step-down transformer is required if the resistance regeneration converter unit is in 400 V class, and coil voltage of the magnetic contactor is in 200 V class.
10. A bus bar is attached to 30 kW or larger drive units.



Be sure to read through Instruction Manual for the actual wiring and use. Use the equipment after you have a full knowledge of the equipment, safety information and instructions.

Servo Motor Connection Example (Rotary Servo Motor) Semi Closed Loop Control System with MR-J4-GF/MR-J4-B/MR-J4-A

GF B A

● For HG-KR/HG-MR series

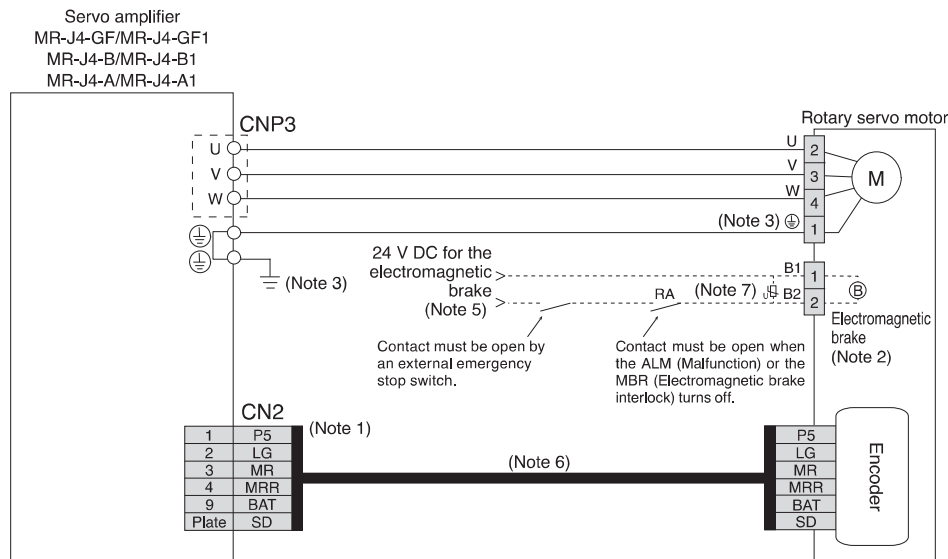

● For HG-SR/HG-JR (9 kW or smaller) series

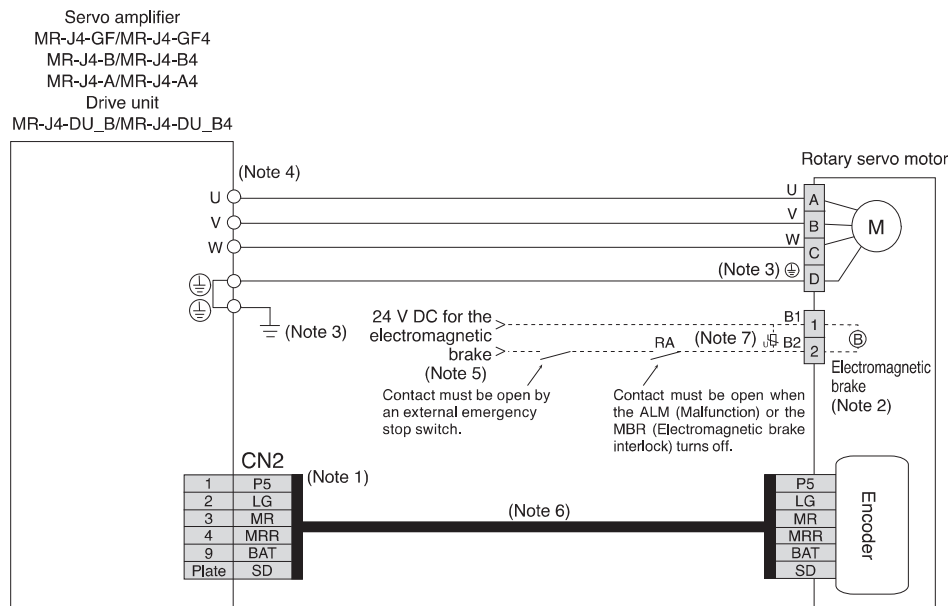

- Notes: 1. The signals shown are applicable when using a two-wire type encoder cable. Four-wire type is also compatible.
 2. This is for the servo motor with electromagnetic brake. The electromagnetic brake terminals (B1, B2) do not have polarity.
 3. Connect the grounding wire to the cabinet protective earth (PE) terminal via the servo amplifier protective earth (PE) terminal for grounding.
 4. Connector or terminal varies depending on the servo amplifier capacities. Refer to the dimensions of the relevant servo amplifier in this catalog for details.
 5. Do not use the 24 V DC interface power supply for the electromagnetic brake. Provide a dedicated power supply to the electromagnetic brake.
 6. Encoder cable is available as an option. Refer to "Servo Motor Instruction Manual (Vol. 3)" when fabricating the cables.
 7. Be sure to install a surge absorber between B1 and B2.



Be sure to read through Instruction Manual for the actual wiring and use. Use the equipment after you have a full knowledge of the equipment, safety information and instructions.

Servo Motor Connection Example (Rotary Servo Motor)

GF B A

Semi Closed Loop Control System with MR-J4-GF/MR-J4-B/MR-J4-A

● For HG-JR 1500 r/min series (11 kW and 15 kW)

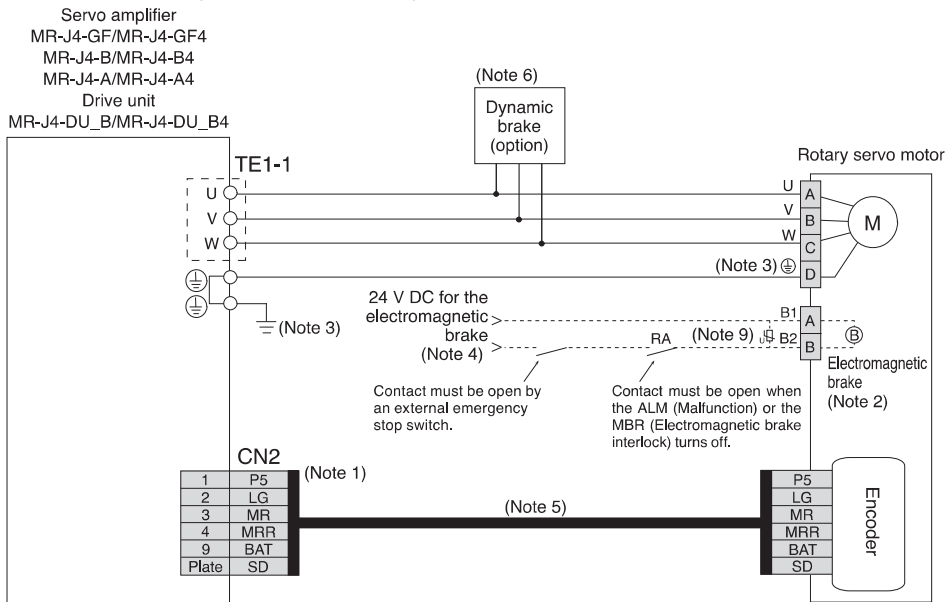

● For HG-JR 1000 r/min series (15 kW or larger) and HG-JR 1500 r/min series (22 kW or larger)

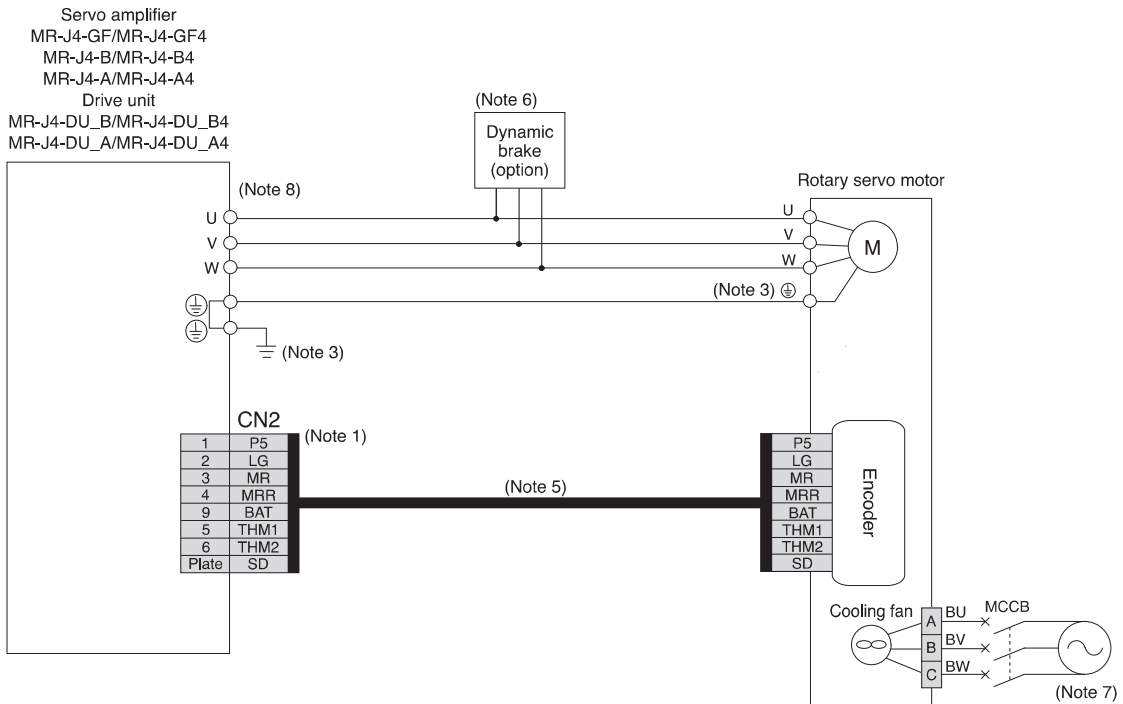

- Notes: 1. The signals shown are applicable when using a two-wire type encoder cable. Four-wire type is also compatible.
 2. This is for the servo motor with electromagnetic brake. The electromagnetic brake terminals (B1, B2) do not have polarity.
 3. Connect the grounding wire to the cabinet protective earth (PE) terminal via the servo amplifier protective earth (PE) terminal for grounding.
 4. Do not use the 24 V DC interface power supply for the electromagnetic brake. Provide a dedicated power supply to the electromagnetic brake.
 5. Encoder cable is available as an option. Refer to "Servo Motor Instruction Manual (Vol. 3)" when fabricating the cables.
 6. Use an external dynamic brake (option) with the servo amplifier. Without the external dynamic brake, a servo motor does not stop immediately at emergency stop and falls in free-run status, causing an accident such as machine collision, etc. Refer to relevant Servo Amplifier Instruction Manual when wiring the dynamic brake.
 7. Be sure to supply power to the cooling fan terminals. Refer to the cooling fan power supply described in the servo motor specifications in this catalog for the required power.
 8. Connector or terminal varies depending on the servo amplifier capacities. Refer to the dimensions of the relevant servo amplifier in this catalog for details.
 9. Be sure to install a surge absorber between B1 and B2.



Be sure to read through Instruction Manual for the actual wiring and use. Use the equipment after you have a full knowledge of the equipment, safety information and instructions.

Servo Motor Connection Example (Rotary Servo Motor) Semi Closed Loop Control System with MR-J4-GF/MR-J4-B/MR-J4-A

GF B A

● For HG-RR/HG-UR series

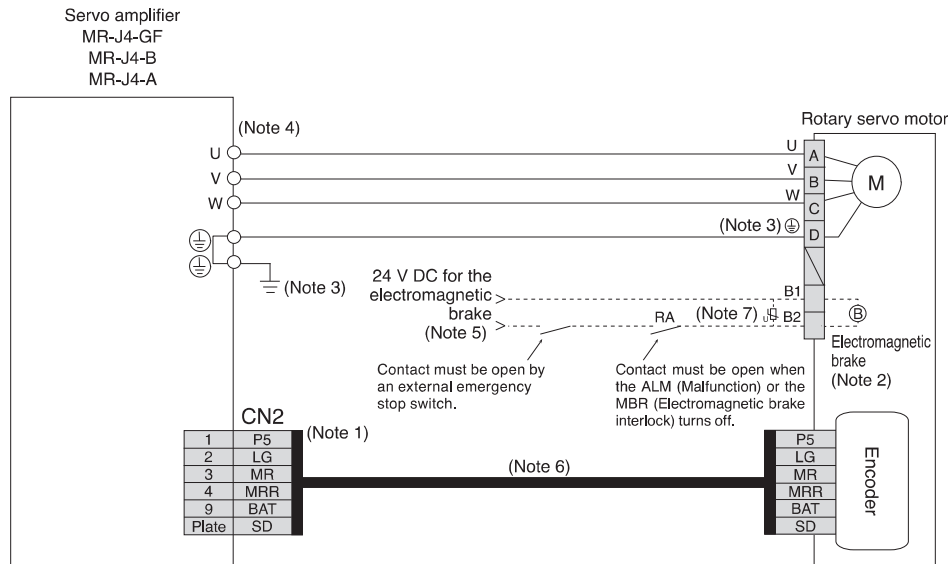

- Notes: 1. The signals shown are applicable when using a two-wire type encoder cable. Four-wire type is also compatible.
 2. This is for the servo with electromagnetic brake. The electromagnetic brake terminals (B1, B2) do not have polarity. A separate connector from the motor power connector is provided as an electromagnetic brake connector for HG-UR202B to HG-UR502B. The pin numbers vary depending on the servo motor capacity. Refer to the dimensions of the relevant servo motor in this catalog for details.
 3. Connect the grounding wire to the cabinet protective earth (PE) terminal via the servo amplifier protective earth (PE) terminal for grounding.
 4. Connector or terminal varies depending on the servo amplifier capacities. Refer to the dimensions of the relevant servo amplifier in this catalog for details.
 5. Do not use the 24 V DC interface power supply for the electromagnetic brake. Provide a dedicated power supply to the electromagnetic brake.
 6. Encoder cable is available as an option. Refer to "Servo Motor Instruction Manual (Vol. 3)" when fabricating the cables.
 7. Be sure to install a surge absorber between B1 and B2.



Be sure to read through Instruction Manual for the actual wiring and use. Use the equipment after you have a full knowledge of the equipment, safety information and instructions.

Servo Motor Connection Example (Rotary Servo Motor)

GF B A

Fully Closed Loop Control System with MR-J4-GF/MR-J4-B/MR-J4-A

● For HG-KR/HG-MR series

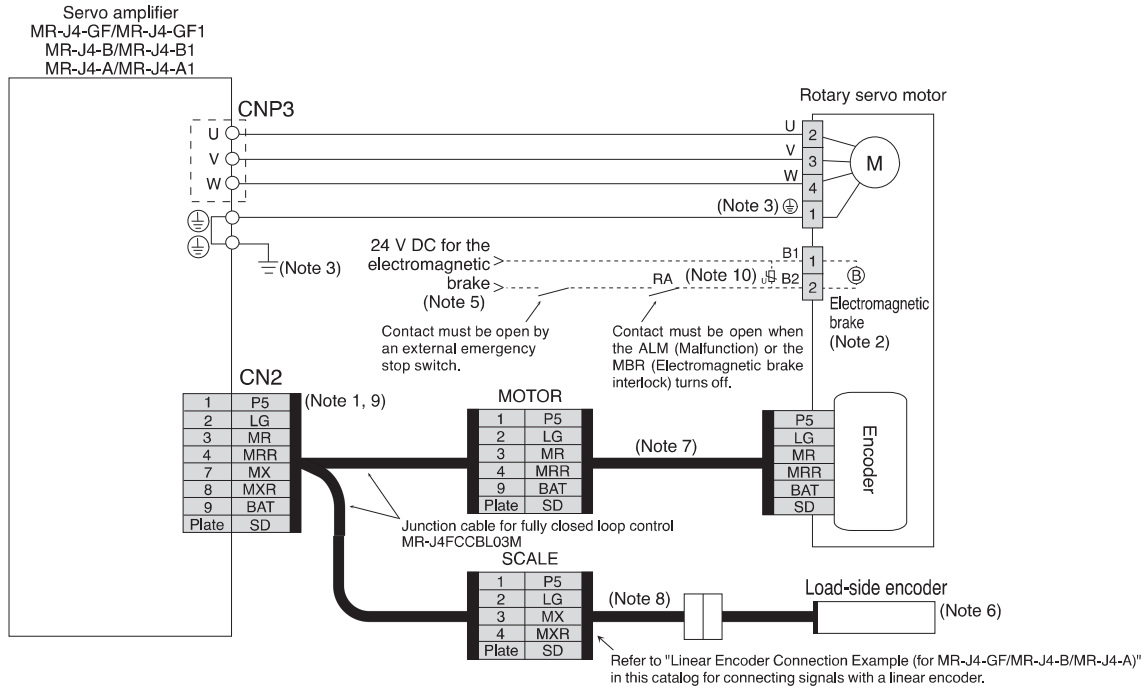

● For HG-SR/HG-JR (9 kW or smaller) series

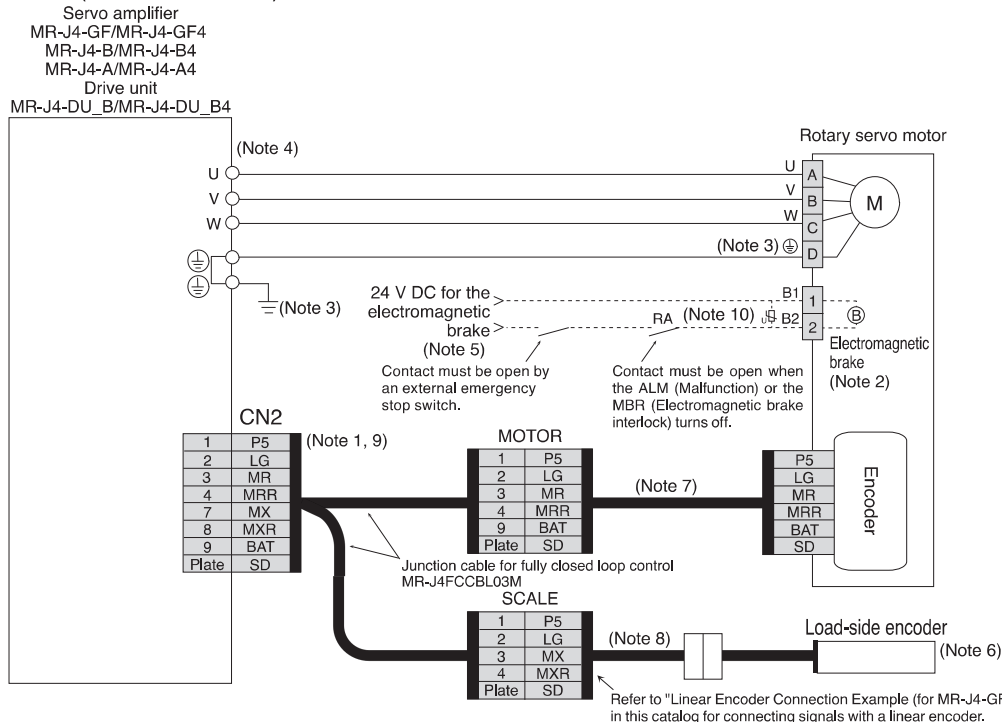

- Notes: 1. For fully closed loop control, the load-side encoder and the servo motor encoder are compatible only with two-wire type communication method. Four-wire type cannot be used.
2. This is for the servo motor with electromagnetic brake. The electromagnetic brake terminals (B1, B2) do not have polarity.
3. Connect the grounding wire to the cabinet protective earth (PE) terminal via the servo amplifier protective earth (PE) terminal for grounding.
4. Connector or terminal varies depending on the servo amplifier capacities. Refer to the dimensions of the relevant servo amplifier in this catalog for details.
5. Do not use the 24 V DC interface power supply for the electromagnetic brake. Provide a dedicated power supply to the electromagnetic brake.
6. For linear encoders, refer to "List of Linear Encoders" under section 3 Linear Servo Motors in this catalog. Refer to relevant Servo Amplifier Instruction Manual for the fully closed loop control with a rotary encoder.
7. Encoder cable is available as an option. Refer to "Servo Motor Instruction Manual (Vol. 3)" when fabricating the cables.
8. Necessary encoder cables vary depending on the load-side encoder. Refer to relevant Instruction Manual.
9. When configuring a fully closed loop control system with MR-J4-GF/_MR-J4-B/_MR-J4-DU_B/_MR-J4-A_, be sure to connect MR-J4FCCBL03M junction cable or a junction cable fabricated using MR-J3THMCN2 connector set to CN2 connector.
10. Be sure to install a surge absorber between B1 and B2.



Be sure to read through Instruction Manual for the actual wiring and use. Use the equipment after you have a full knowledge of the equipment, safety information and instructions.

Servo Motor Connection Example (Rotary Servo Motor)
Fully Closed Loop Control System with MR-J4-GF/MR-J4-B/MR-J4-A

GF B A

● For HG-JR 1500 r/min series (11 kW and 15 kW)

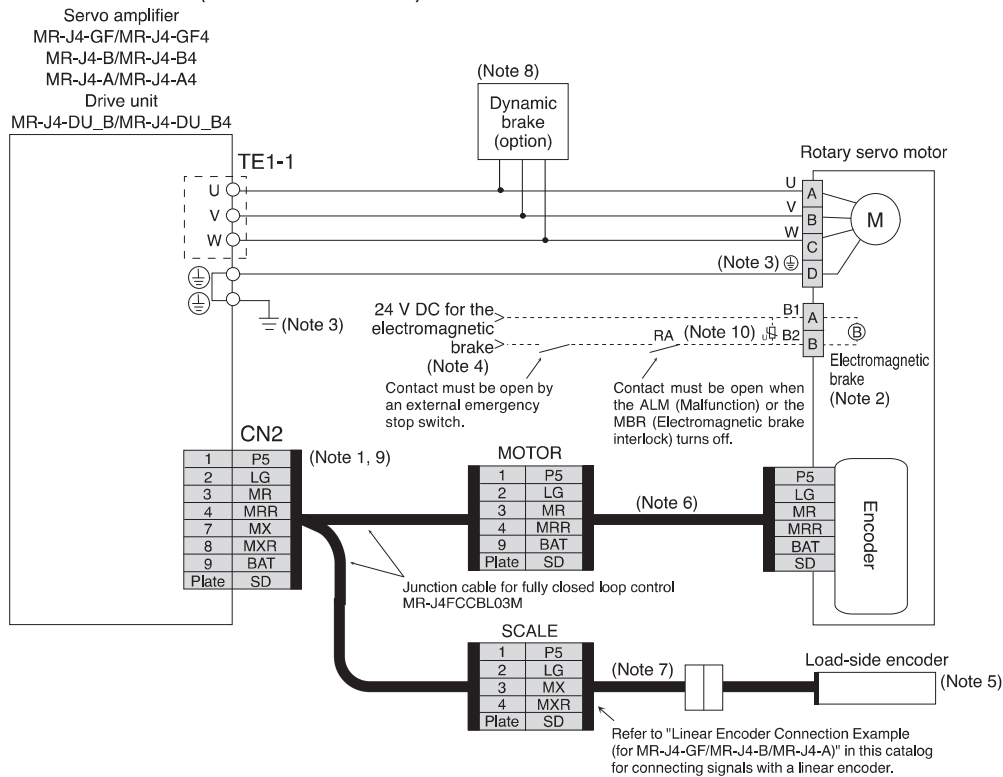

- Notes: 1. For fully closed loop control, the load-side encoder and the servo motor encoder are compatible only with two-wire type communication method. Four-wire type cannot be used.
 2. This is for the servo motor with electromagnetic brake. The electromagnetic brake terminals (B1, B2) do not have polarity.
 3. Connect the grounding wire to the cabinet protective earth (PE) terminal via the servo amplifier protective earth (PE) terminal for grounding.
 4. Do not use the 24 V DC interface power supply for the electromagnetic brake. Provide a dedicated power supply to the electromagnetic brake.
 5. For linear encoders, refer to "List of Linear Encoders" under section 3 Linear Servo Motors in this catalog. Refer to relevant Servo Amplifier Instruction Manual for the fully closed loop control with a rotary encoder.
 6. Encoder cable is available as an option. Refer to "Servo Motor Instruction Manual (Vol. 3)" when fabricating the cables.
 7. Necessary encoder cables vary depending on the load-side encoder. Refer to relevant Instruction Manual.
 8. Use an external dynamic brake (option) with the servo amplifier. Without the external dynamic brake, a servo motor does not stop immediately at emergency stop and falls in free-run status, causing an accident such as machine collision, etc. Refer to relevant Servo Amplifier Instruction Manual when wiring the dynamic brake.
 9. When configuring a fully closed loop control system with MR-J4-GF/_MR-J4-B/_MR-J4-DU_B/_MR-J4-A_, be sure to connect MR-J4FCCBL03M junction cable or a junction cable fabricated using MR-J3THMCN2 connector set to CN2 connector.
 10. Be sure to install a surge absorber between B1 and B2.

Be sure to read through Instruction Manual for the actual wiring and use. Use the equipment after you have a full knowledge of the equipment, safety information and instructions.

Servo Amplifiers
 Rotary Servo Motors
 Linear Servo Motors
 Direct Drive Motors
 Options/Peripheral Equipment
 LV/S/Wires
 Product List
 Cautions

Servo Motor Connection Example (Rotary Servo Motor)

Fully Closed Loop Control System with MR-J4-GF/MR-J4-B/MR-J4-A

- For HG-JR 1000 r/min series (15 kW or larger) and HG-JR 1500 r/min series (22 kW or larger)

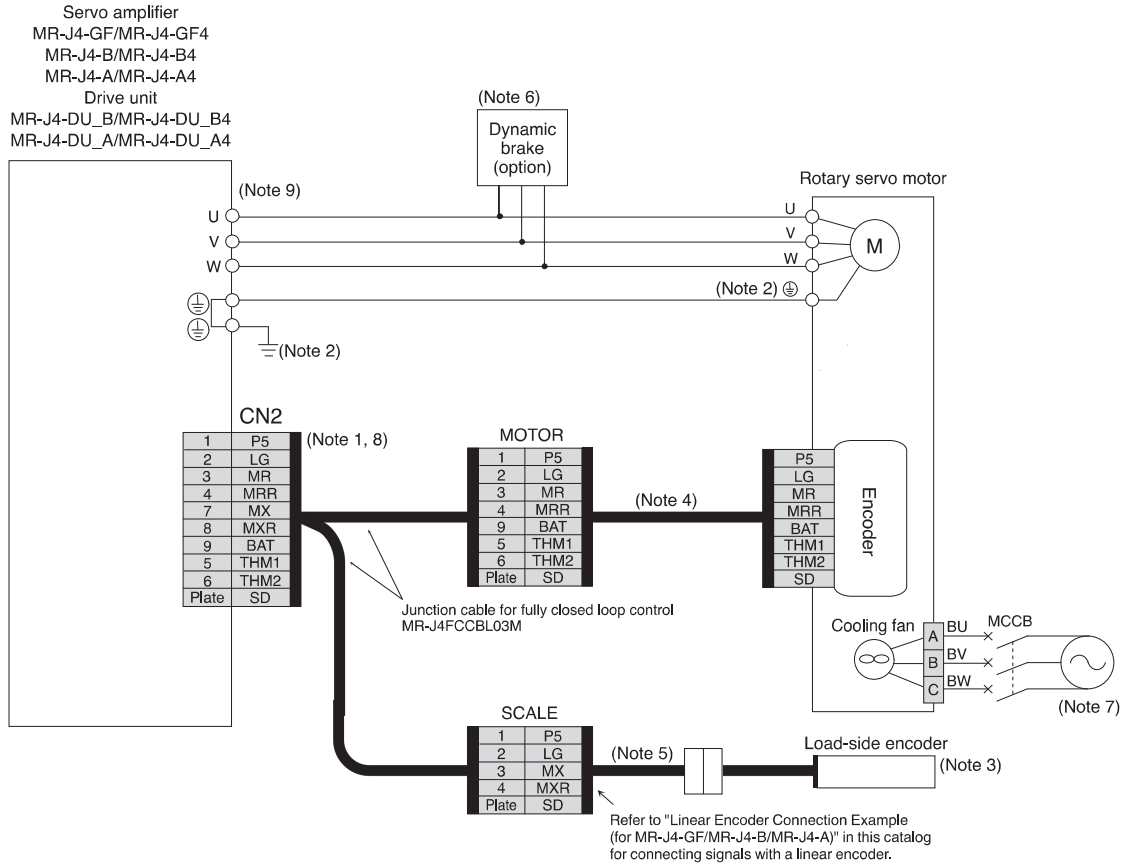

- Notes: 1. For fully closed loop control, the load-side encoder and the servo motor encoder are compatible only with two-wire type communication method. Four-wire type cannot be used.
2. Connect the grounding wire to the cabinet protective earth (PE) terminal via the servo amplifier protective earth (PE) terminal for grounding.
3. For linear encoders, refer to "List of Linear Encoders" under section 3 Linear Servo Motors in this catalog. Refer to relevant Servo Amplifier Instruction Manual for the fully closed loop control with a rotary encoder.
4. Encoder cable is available as an option. Refer to "Servo Motor Instruction Manual (Vol. 3)" when fabricating the cables.
5. Necessary encoder cables vary depending on the load-side encoder. Refer to relevant Instruction Manual.
6. Use an external dynamic brake (option) with the servo amplifier. Without the external dynamic brake, a servo motor does not stop immediately at emergency stop and falls in free-run status, causing an accident such as machine collision, etc. Refer to relevant Servo Amplifier Instruction Manual when wiring the dynamic brake.
7. Be sure to supply power to the cooling fan terminals. Refer to the cooling fan power supply described in the servo motor specifications in this catalog for the required power.
8. When configuring a fully closed loop control system with MR-J4-GF_/MR-J4-B_/MR-J4-DU_B_/MR-J4-A_, be sure to connect MR-J4FCCBL03M junction cable or a junction cable fabricated using MR-J3THMCN2 connector set to CN2 connector.
9. Connector or terminal varies depending on the servo amplifier capacities. Refer to the dimensions of the relevant servo amplifier in this catalog for details.



Be sure to read through Instruction Manual for the actual wiring and use. Use the equipment after you have a full knowledge of the equipment, safety information and instructions.

Servo Motor Connection Example (Rotary Servo Motor) Fully Closed Loop Control System with MR-J4-GF/MR-J4-B/MR-J4-A

GF B A

● For HG-RR/HG-UR series

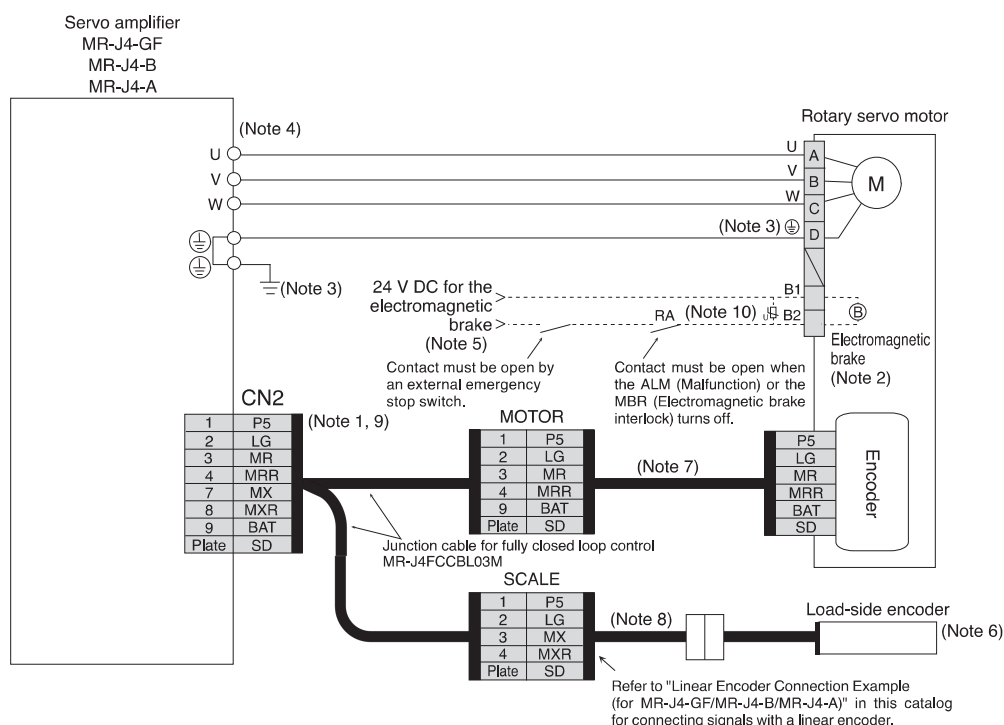

- Notes: 1. For fully closed loop control, the load-side encoder and the servo motor encoder are compatible only with two-wire type communication method. Four-wire type cannot be used.
2. This is for the servo motor with electromagnetic brake. The electromagnetic brake terminals (B1, B2) do not have polarity. A separate connector from the motor power connector is provided as an electromagnetic brake connector for HG-UR202B to HG-UR502B. The pin numbers vary depending on the servo motor capacity. Refer to the dimensions of the relevant servo motor in this catalog for details.
3. Connect the grounding wire to the cabinet protective earth (PE) terminal via the servo amplifier protective earth (PE) terminal for grounding.
4. Connector or terminal varies depending on the servo amplifier capacities. Refer to the dimensions of the relevant servo amplifier in this catalog for details.
5. Do not use the 24 V DC interface power supply for the electromagnetic brake. Provide a dedicated power supply to the electromagnetic brake.
6. For linear encoders, refer to "List of Linear Encoders" under section 3 Linear Servo Motors in this catalog. Refer to relevant Servo Amplifier Instruction Manual for the fully closed loop control with a rotary encoder.
7. Encoder cable is available as an option. Refer to "Servo Motor Instruction Manual (Vol. 3)" when fabricating the cables.
8. Necessary encoder cables vary depending on the load-side encoder. Refer to relevant Instruction Manual.
9. When configuring a fully closed loop control system with MR-J4-GF/MR-J4-B/MR-J4-A, be sure to connect MR-J4FCCBL03M junction cable or a junction cable fabricated using MR-J3THMCN2 connector set to CN2 connector.
10. Be sure to install a surge absorber between B1 and B2.

 Be sure to read through Instruction Manual for the actual wiring and use. Use the equipment after you have a full knowledge of the equipment, safety information and instructions.

Servo Amplifiers
Rotary Servo Motors
Linear Servo Motors
Direct Drive Motors
Options/Peripheral Equipment
LV/S/Wires
Product List
Cautions

Servo Motor Connection Example (Linear Servo Motor)

Linear Servo Motor System with MR-J4-GF/MR-J4-B/MR-J4-A

● For LM-H3/LM-F/LM-K2/LM-U2 series

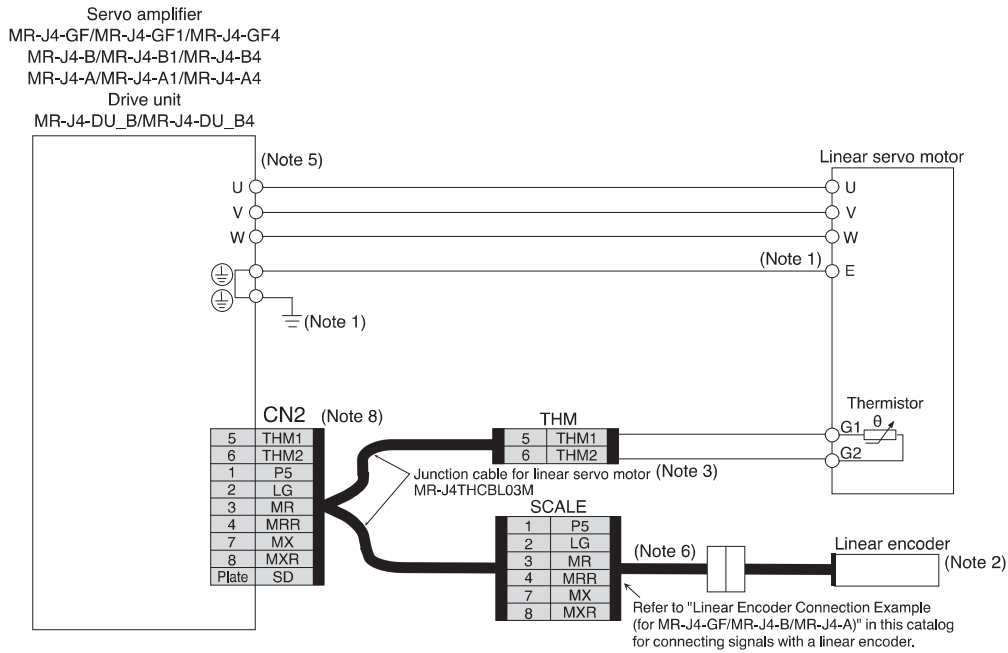

Linear Encoder Connection Example (for MR-J4-GF/MR-J4-B/MR-J4-A)

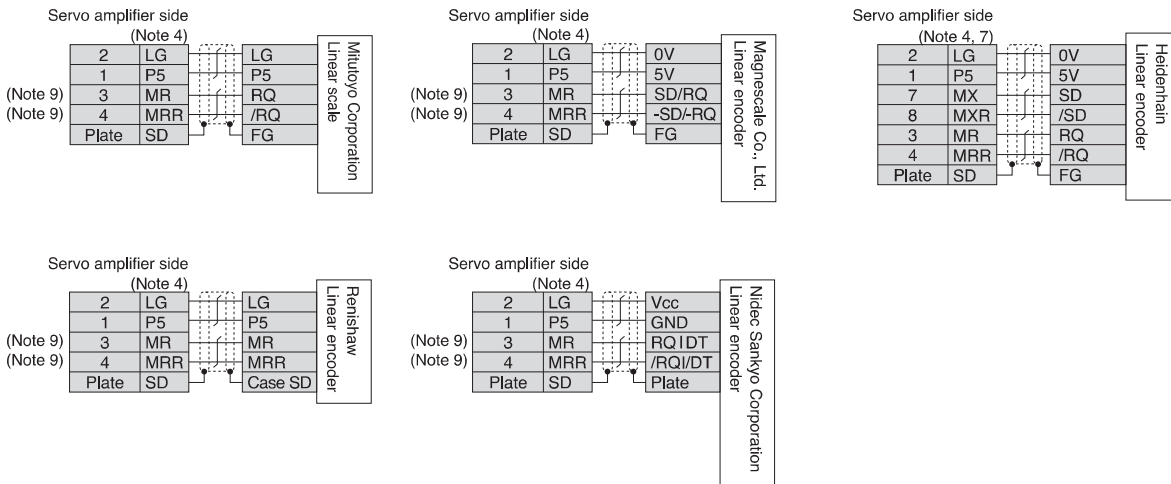

- Notes: 1. Connect the grounding wire to the cabinet protective earth (PE) terminal via the servo amplifier protective earth (PE) terminal for grounding.
2. For linear encoders, refer to "List of Linear Encoders" under section 3 Linear Servo Motors in this catalog.
3. MR-J4THCBL03M junction cable for linear servo motor is compatible with both two-wire and four-wire type linear encoders.
4. For the number of the wire pairs for LG and P5, refer to "Linear Encoder Instruction Manual."
5. Connector or terminal varies depending on the servo amplifier capacities. Refer to the dimensions of the relevant servo amplifier in this catalog for details.
6. Necessary encoder cables vary depending on the linear encoder. Refer to relevant Instruction Manual.
7. When fully closed loop control is configured with a rotary servo motor, the load-side encoder and the servo motor encoder are compatible only with two-wire type communication method. Four-wire type cannot be used.
8. When using a linear servo motor with MR-J4-GF_/MR-J4-B_/MR-J4-DU_B_/MR-J4-A_, be sure to connect MR-J4THCBL03M junction cable or a junction cable fabricated using MR-J3THMCN2 connector set to CN2 connector.
9. For the fully closed loop control, the signals of 3-pin and 4-pin are as follows:
3-pin: MX
4-pin: MXR



Be sure to read through Instruction Manual for the actual wiring and use. Use the equipment after you have a full knowledge of the equipment, safety information and instructions.

Servo Motor Connection Example (Direct Drive Motor)

GF GF-RJ B B-RJ A A-RJ

● For TM-RG2M/TM-RU2M/TM-RFM series (incremental system)

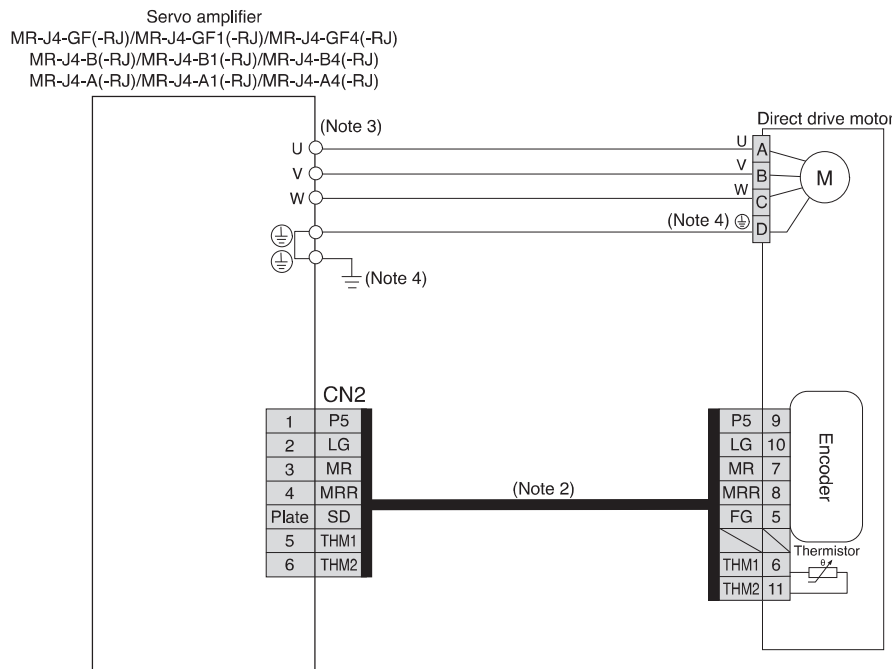

● For TM-RG2M/TM-RU2M/TM-RFM series (absolute position detection system)

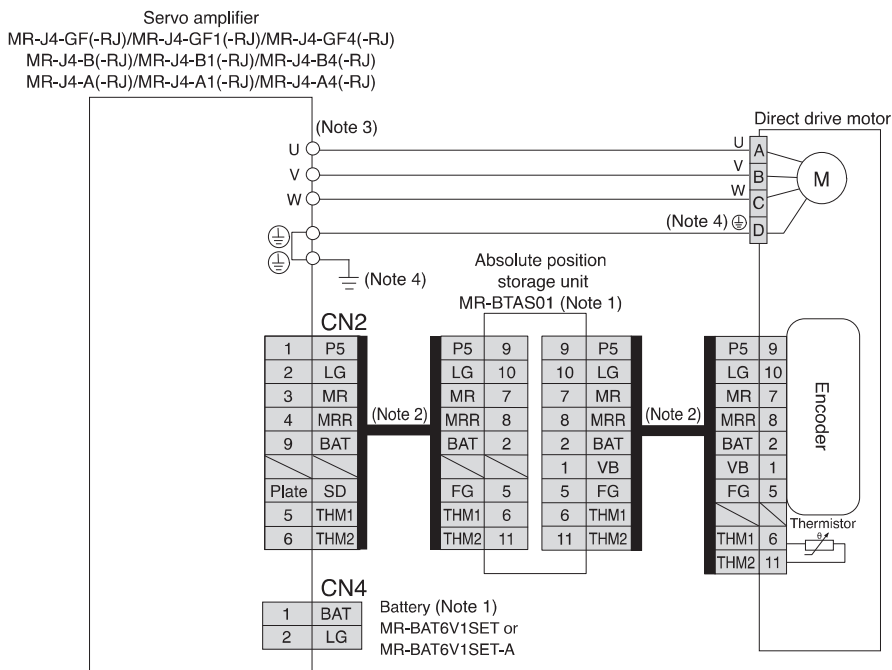

- Notes: 1. An MR-BTAS01 absolute position storage unit and MR-BAT6V1SET or MR-BAT6V1SET-A battery (sold as options) are required for absolute position detection system. Required battery varies depending on the servo amplifiers. Refer to configuration example for each servo amplifier in this catalog. Refer to relevant Servo Amplifier Instruction Manual and "TM-RFM TM-RG2M TM-RU2M Direct Drive Motor Instruction Manual" for details of absolute position detection system.
2. Fabricate this encoder cable. Refer to "TM-RFM TM-RG2M TM-RU2M Direct Drive Motor Instruction Manual" for fabricating the encoder cable.
3. Connector or terminal varies depending on the servo amplifier capacities. Refer to the dimensions of the relevant servo amplifier in this catalog for details.
4. Connect the grounding wire to the cabinet protective earth (PE) terminal via the servo amplifier protective earth (PE) terminal for grounding.



Be sure to read through Instruction Manual for the actual wiring and use. Use the equipment after you have a full knowledge of the equipment, safety information and instructions.

Servo Amplifiers

Encoder Connection Specifications

GF **GF-RJ** **B** **B-RJ** **WB** **A** **A-RJ**

When configuring a linear servo motor system or a fully closed loop control system, or when using the scale measurement function, use the servo amplifier with the following software version.

Refer to the following table for the encoder communication method compatible with each system and for the servo amplifier connector to which a load-side encoder should be connected.

Operation mode	External encoder communication method	Connector to be connected with the external encoder									
		MR-J4-GF_	MR-J4-GF_-RJ	MR-J4-B_	MR-J4-B_-RJ	MR-J4-DU_B_	MR-J4-DU_B_-RJ	MR-J4-A_	MR-J4-A_-RJ	MR-J4W2-B	MR-J4W3-B
Linear servo motor system (Note 9)	Two-wire type	CN2 (Note 1)	CN2	CN2 (Note 1)	CN2 (Note 1)	CN2 (Note 1, 6)	CN2 (Note 1)	CN2A (Note 1)	CN2B (Note 1)	CN2A (Note 1)	CN2B (Note 1)
	Four-wire type									CN2C (Note 1)	
	A/B/Z-phase differential output type		CN2L (Note 8)		CN2L (Note 8)		CN2L (Note 8)				
Fully closed loop control system	Two-wire type	CN2		CN2 (Note 2, 3, 5)		CN2 (Note 2, 3, 6)		CN2A (Note 2, 4, 5)	CN2B (Note 2, 4, 5)		
	Four-wire type		CN2L		CN2L		CN2L				
	A/B/Z-phase differential output type										
Scale measurement function	Two-wire type	CN2		CN2 (Note 2, 3, 7)				CN2A (Note 2, 4, 7)	CN2B (Note 2, 4, 7)		
	Four-wire type		CN2L		CN2L (Note 7)						
	A/B/Z-phase differential output type										

- Notes: 1. MR-J4THCBL03M junction cable is required.
 2. MR-J4FCCBL03M junction cable is required.
 3. MR-J4-GF_/MR-J4-B_/MR-DU_B_/MR-J4-A_/MR-J4-DU_A_ is not compatible with a servo motor encoder with four-wire type communication method. Use MR-J4-GF_-RJ/MR-J4-B_-RJ/MR-DU_B_-RJ/MR-J4-A_-RJ/MR-J4-DU_A_-RJ.
 4. MR-J4W2-B servo amplifier does not support a servo motor encoder with four-wire communication method. Use MR-J4-B-RJ servo amplifier.
 5. Supported by the servo amplifiers with software version A3 or later
 6. Supported by the servo amplifiers with software version A5 or later
 7. Supported by the servo amplifiers with software version A8 or later
 8. Connect a thermistor to CN2 connector.
 9. Refer to pp. 1-4 to 1-6 and 1-8 in this catalog for servo amplifier that is compatible with linear servo motors.

Servo Motor Connection Example (Rotary Servo Motor)

GF-RJ B-RJ A-RJ

Fully Closed Loop Control System with MR-J4-GF-RJ/MR-J4-B-RJ/MR-J4-A-RJ

● For HG-KR/HG-MR series

Servo amplifier
MR-J4-GF-RJ/MR-J4-GF1-RJ
MR-J4-B-RJ/MR-J4-B1-RJ
MR-J4-A-RJ/MR-J4-A1-RJ

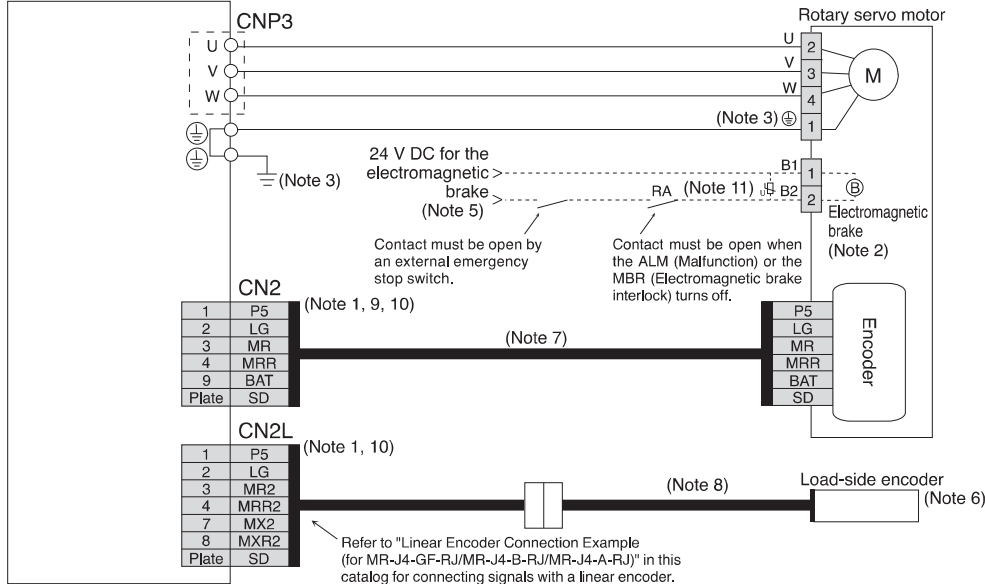

● For HG-SR/HG-JR (9 kW or smaller) series

Servo amplifier
MR-J4-GF-RJ/MR-J4-GF4-RJ
MR-J4-B-RJ/MR-J4-B4-RJ
MR-J4-A-RJ/MR-J4-A4-RJ
Drive unit
MR-J4-DU_B-RJ/MR-J4-DU_B4-RJ

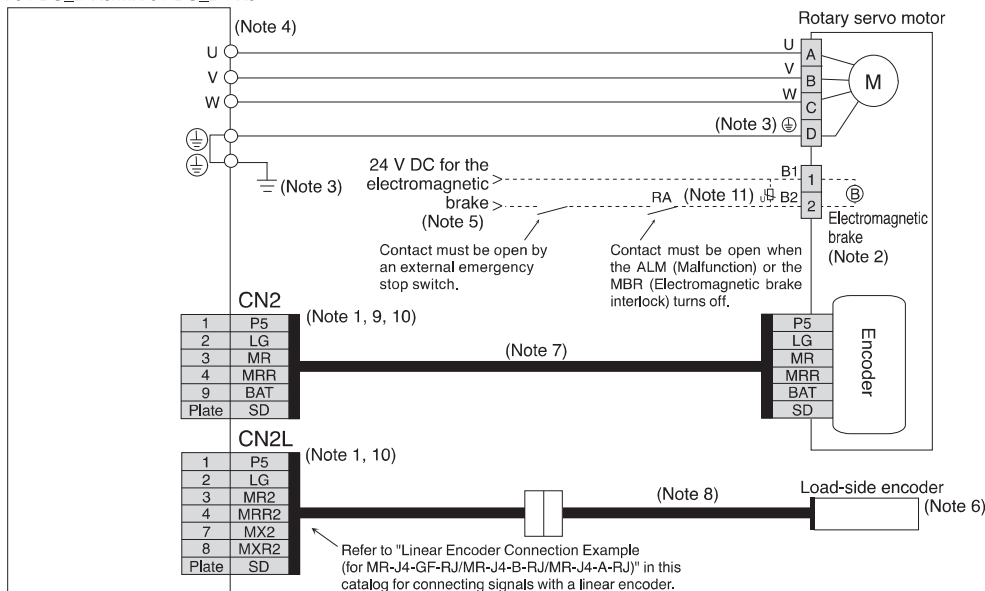

- Notes: 1. The load-side encoder and the servo motor encoder are compatible with both two-wire and four-wire type communication methods.
2. This is for the servo motor with electromagnetic brake. The electromagnetic brake terminals (B1, B2) do not have polarity.
3. Connect the grounding wire to the cabinet protective earth (PE) terminal via the servo amplifier protective earth (PE) terminal for grounding.
4. Connector or terminal varies depending on the servo amplifier capacities. Refer to the dimensions of the relevant servo amplifier in this catalog for details.
5. Do not use the 24 V DC interface power supply for the electromagnetic brake. Provide a dedicated power supply to the electromagnetic brake.
6. For linear encoders, refer to "List of Linear Encoders" under section 3 Linear Servo Motors in this catalog. Refer to relevant Servo Amplifier Instruction Manual for the fully closed loop control with a rotary encoder.
7. Encoder cable is available as an option. Refer to "Servo Motor Instruction Manual (Vol. 3)" when fabricating the cables.
8. Necessary encoder cables vary depending on the load-side encoder. Refer to relevant Instruction Manual.
9. This wiring of the servo motor encoder is applicable for the two-wire type communication method.
10. When configuring a fully closed loop control system with MR-J4-GF-RJ/MR-J4-B-RJ/MR-J4-DU_B-RJ/MR-J4-A-RJ, be sure to connect a servo motor encoder to CN2 connector and a load-side encoder to CN2L connector. Do not use MR-J4FCCBL03M junction cable or a junction cable fabricated using MR-J3THMCN2 connector set.
11. Be sure to install a surge absorber between B1 and B2.



Be sure to read through Instruction Manual for the actual wiring and use. Use the equipment after you have a full knowledge of the equipment, safety information and instructions.

Servo Motor Connection Example (Rotary Servo Motor)

GF-RJ B-RJ A-RJ

Fully Closed Loop Control System with MR-J4-GF-RJ/MR-J4-B-RJ/MR-J4-A-RJ

● For HG-JR 1500 r/min series (11 kW and 15 kW)

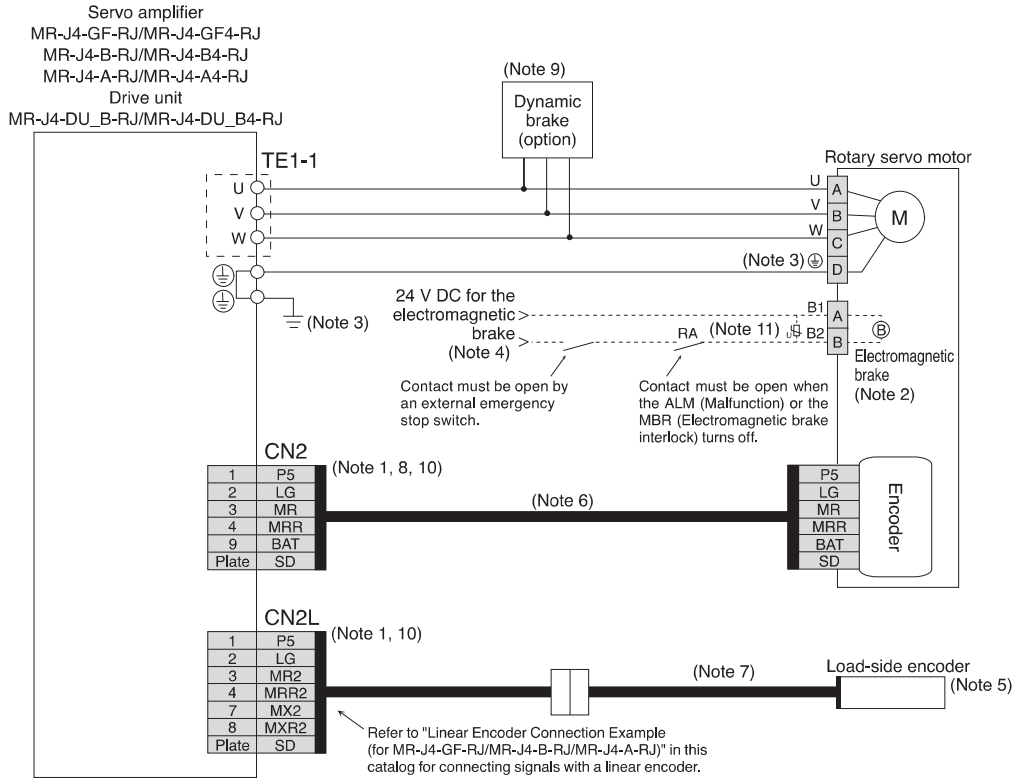

- Notes: 1. The load-side encoder and the servo motor encoder are compatible with both two-wire and four-wire type communication methods.
 2. This is for the servo motor with electromagnetic brake. The electromagnetic brake terminals (B1, B2) do not have polarity.
 3. Connect the grounding wire to the cabinet protective earth (PE) terminal via the servo amplifier protective earth (PE) terminal for grounding.
 4. Do not use the 24 V DC interface power supply for the electromagnetic brake. Provide a dedicated power supply to the electromagnetic brake.
 5. For linear encoders, refer to "List of Linear Encoders" under section 3 Linear Servo Motors in this catalog. Refer to relevant Servo Amplifier Instruction Manual for the fully closed loop control with a rotary encoder.
 6. Encoder cable is available as an option. Refer to "Servo Motor Instruction Manual (Vol. 3)" when fabricating the cables.
 7. Necessary encoder cables vary depending on the load-side encoder. Refer to relevant Instruction Manual.
 8. This wiring of the servo motor encoder is applicable for the two-wire type communication method.
 9. Use an external dynamic brake (option) with the servo amplifier. Without the external dynamic brake, a servo motor does not stop immediately at emergency stop and falls in free-run status, causing an accident such as machine collision, etc. Refer to relevant Servo Amplifier Instruction Manual when wiring the dynamic brake.
 10. When configuring a fully closed loop control system with MR-J4-GF-RJ/MR-J4-B-RJ/MR-J4-DU_B-RJ/MR-J4-A-RJ, be sure to connect a servo motor encoder to CN2 connector and a load-side encoder to CN2L connector. Do not use MR-J4FCCBL03M junction cable or a junction cable fabricated using MR-J3THMCN2 connector set.
 11. Be sure to install a surge absorber between B1 and B2.



Be sure to read through Instruction Manual for the actual wiring and use. Use the equipment after you have a full knowledge of the equipment, safety information and instructions.

Servo Motor Connection Example (Rotary Servo Motor)

GF-RJ B-RJ A-RJ

Fully Closed Loop Control System with MR-J4-GF-RJ/MR-J4-B-RJ/MR-J4-A-RJ

● For HG-JR 1000 r/min series (15 kW or larger) and HG-JR 1500 r/min series (22 kW or larger)

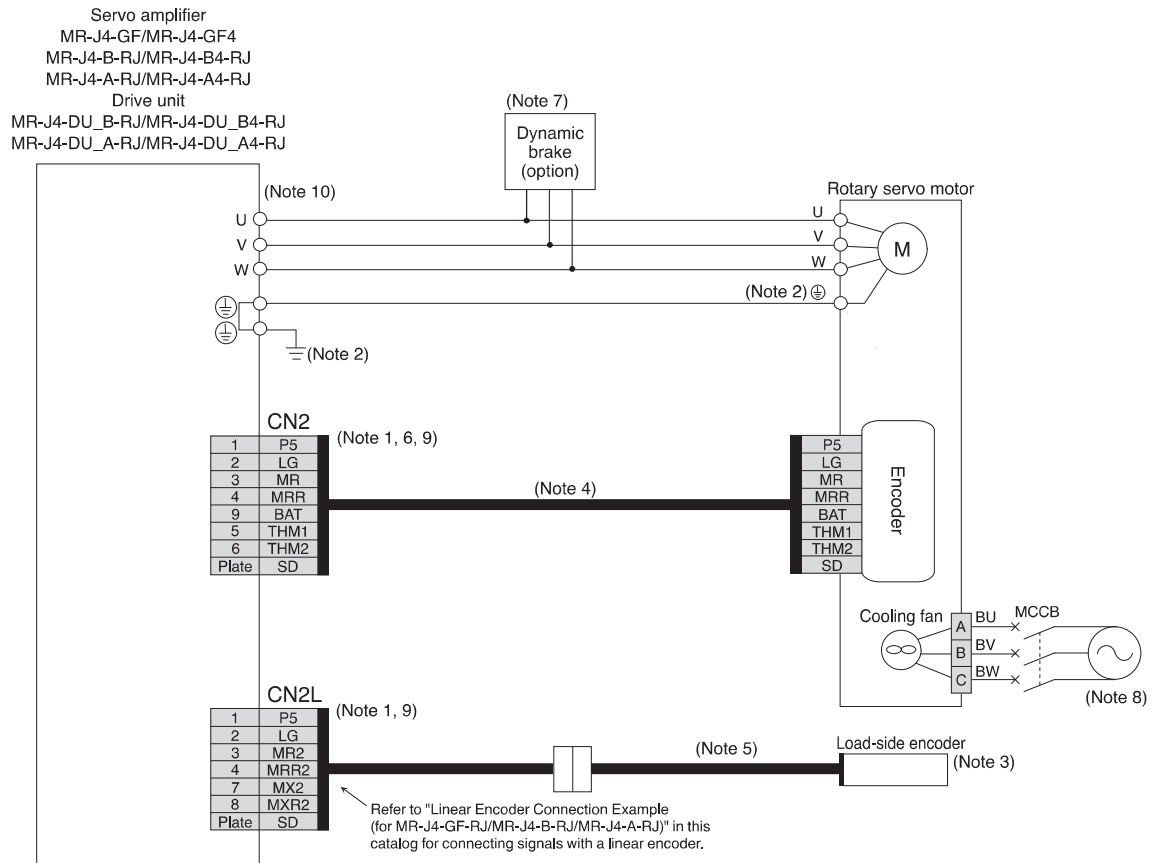

- Notes: 1. The load-side encoder and the servo motor encoder are compatible with both two-wire and four-wire type communication methods.
2. Connect the grounding wire to the cabinet protective earth (PE) terminal via the servo amplifier protective earth (PE) terminal for grounding.
3. For linear encoders, refer to "List of Linear Encoders" under section 3 Linear Servo Motors in this catalog. Refer to relevant Servo Amplifier Instruction Manual for the fully closed loop control with a rotary encoder.
4. Encoder cable is available as an option. Refer to "Servo Motor Instruction Manual (Vol. 3)" when fabricating the cables.
5. Necessary encoder cables vary depending on the load-side encoder. Refer to relevant Instruction Manual.
6. This wiring of the servo motor encoder is applicable for the two-wire type communication method.
7. Use an external dynamic brake (option) with the servo amplifier. Without the external dynamic brake, a servo motor does not stop immediately at emergency stop and falls in free-run status, causing an accident such as machine collision, etc. Refer to relevant Servo Amplifier Instruction Manual when wiring the dynamic brake.
8. Be sure to supply power to the cooling fan terminals. Refer to the cooling fan power supply described in the servo motor specifications in this catalog for the required power.
9. When configuring a fully closed loop control system with MR-J4-GF-RJ/MR-J4-B-RJ/MR-J4-DU_B-RJ/MR-J4-A-RJ, be sure to connect a servo motor encoder to CN2 connector and a load-side encoder to CN2L connector. Do not use MR-J4FCCBL03M junction cable or a junction cable fabricated using MR-J3THMCN2 connector set.
10. Connector or terminal varies depending on the servo amplifier capacities. Refer to the dimensions of the relevant servo amplifier in this catalog for details.

Be sure to read through Instruction Manual for the actual wiring and use. Use the equipment after you have a full knowledge of the equipment, safety information and instructions.

Servo Amplifiers

Rotary Servo Motors

Linear Servo Motors

Direct Drive Motors

Options/Peripheral Equipment

LVS/Wires

Product List

Cautions

Servo Motor Connection Example (Rotary Servo Motor)

GF-RJ B-RJ A-RJ

Fully Closed Loop Control System with MR-J4-GF-RJ/MR-J4-B-RJ/MR-J4-A-RJ

● For HG-RR/HG-UR series

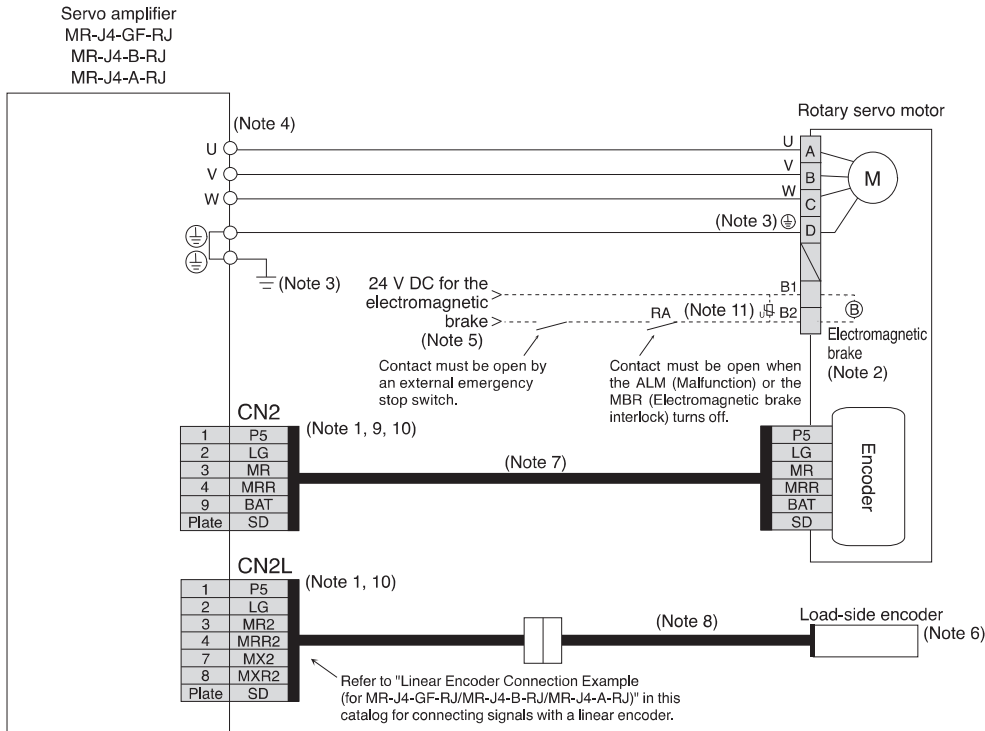

- Notes: 1. The load-side encoder and the servo motor encoder are compatible with both two-wire and four-wire type communication methods.
 2. This is for the servo motor with electromagnetic brake. The electromagnetic brake terminals (B1, B2) do not have polarity. A separate connector from the motor power connector is provided as an electromagnetic brake connector for HG-UR202B to HG-UR502B. The pin numbers vary depending on the servo motor capacity. Refer to the dimensions of the relevant servo motor in this catalog for details.
 3. Connect the grounding wire to the cabinet protective earth (PE) terminal via the servo amplifier protective earth (PE) terminal for grounding.
 4. Connector or terminal varies depending on the servo amplifier capacities. Refer to the dimensions of the relevant servo amplifier in this catalog for details.
 5. Do not use the 24 V DC interface power supply for the electromagnetic brake. Provide a dedicated power supply to the electromagnetic brake.
 6. For linear encoders, refer to "List of Linear Encoders" under section 3 Linear Servo Motors in this catalog. Refer to relevant Servo Amplifier Instruction Manual for the fully closed loop control with a rotary encoder.
 7. Encoder cable is available as an option. Refer to "Servo Motor Instruction Manual (Vol. 3)" when fabricating the cables.
 8. Necessary encoder cables vary depending on the load-side encoder. Refer to relevant Instruction Manual.
 9. This wiring of the servo motor encoder is applicable for the two-wire type communication method.
 10. When configuring a fully closed loop control system with MR-J4-GF-RJ/MR-J4-B-RJ/MR-J4-A-RJ, be sure to connect a servo motor encoder to CN2 connector and a load-side encoder to CN2L connector. Do not use MR-J4FCCBL03M junction cable or a junction cable fabricated using MR-J3THMCN2 connector set.
 11. Be sure to install a surge absorber between B1 and B2.



Be sure to read through Instruction Manual for the actual wiring and use. Use the equipment after you have a full knowledge of the equipment, safety information and instructions.

Servo Motor Connection Example (Linear Servo Motor)

GF-RJ B-RJ A-RJ

Linear Servo Motor System with MR-J4-GF-RJ/MR-J4-B-RJ/MR-J4-A-RJ (LM-H3, LM-F, LM-K2, LM-U2)

●Connecting a serial linear encoder

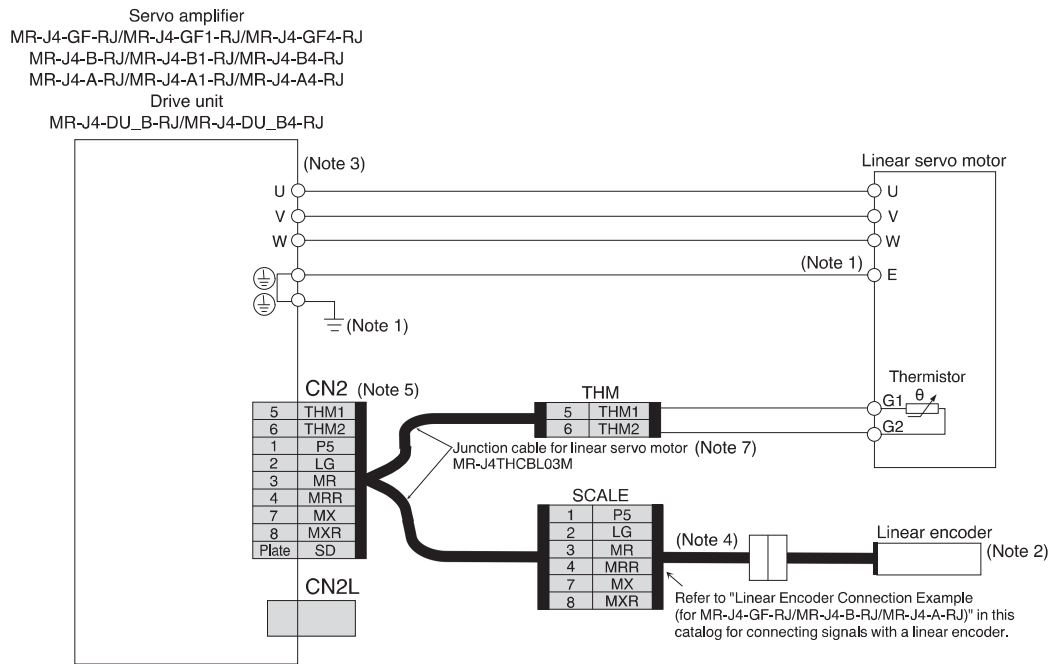

●Connecting an A/B/Z-phase differential output linear encoder

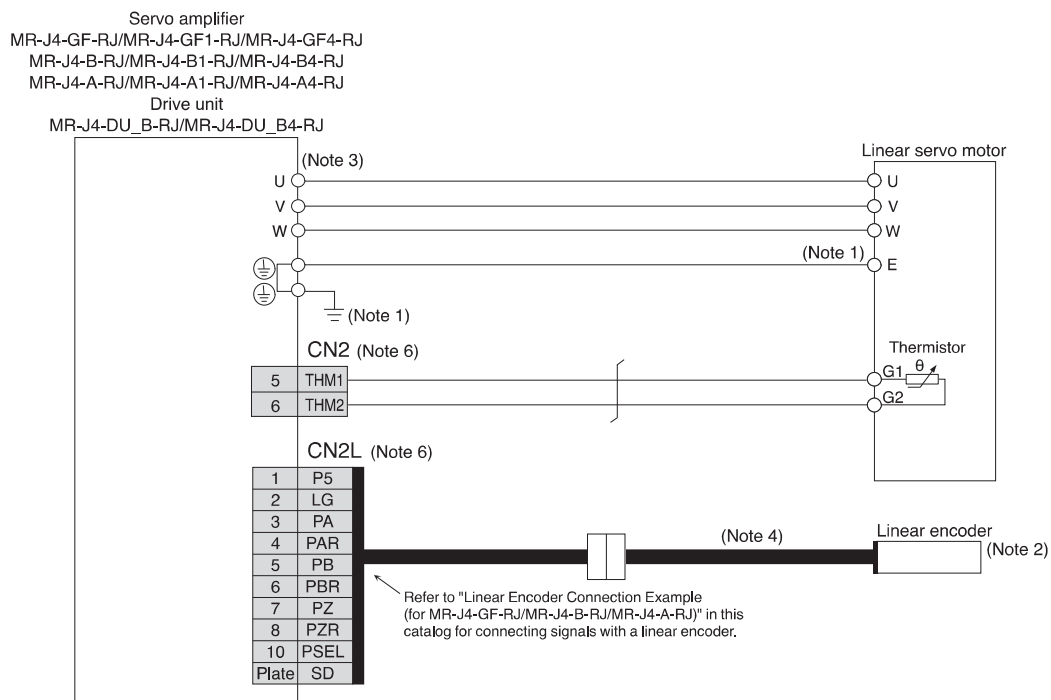

- Notes: 1. Connect the grounding wire to the cabinet protective earth (PE) terminal via the servo amplifier protective earth (PE) terminal for grounding.
 2. For linear encoders, refer to "List of Linear Encoders" under section 3 Linear Servo Motors in this catalog.
 3. Connector or terminal varies depending on the servo amplifier capacities. Refer to the dimensions of the relevant servo amplifier in this catalog for details.
 4. Necessary encoder cables vary depending on the linear encoder. Refer to relevant Instruction Manual.
 5. When configuring a linear servo system with MR-J4-GF-RJ/MR-J4-B-RJ/MR-J4-DU_B-RJ/MR-J4-A-RJ and a serial linear encoder, be sure to connect MR-J4THCBL03M junction cable or a junction cable fabricated using MR-J3THMCN2 connector set to CN2 connector.
 6. When configuring a linear servo system with MR-J4-GF-RJ/MR-J4-B-RJ/MR-J4-DU_B-RJ/MR-J4-A-RJ and an A/B/Z-phase differential output type linear encoder, be sure to connect a thermistor to CN2 connector and the linear encoder to CN2L connector. Do not use MR-J4THCBL03M junction cable or a junction cable fabricated using MR-J3THMCN2 connector set.
 7. MR-J4THCBL03M junction cable for linear servo motor is compatible with both two-wire and four-wire type linear encoders.

Be sure to read through Instruction Manual for the actual wiring and use. Use the equipment after you have a full knowledge of the equipment, safety information and instructions.

Servo Amplifiers
Rotary Servo Motors
Linear Servo Motors
Direct Drive Motors
Options/Peripheral Equipment
LV/S/Wires
Product List
Cautions

Servo Amplifiers

Linear Encoder Connection Example (for MR-J4-GF-RJ/MR-J4-B-RJ/MR-J4-A-RJ) **GF-RJ** **B-RJ** **A-RJ**

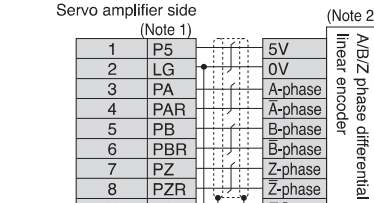
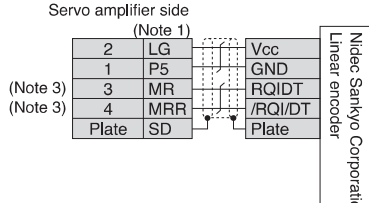
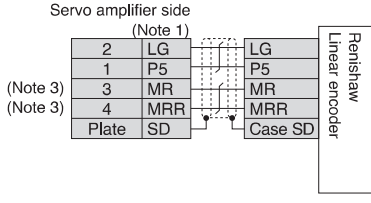
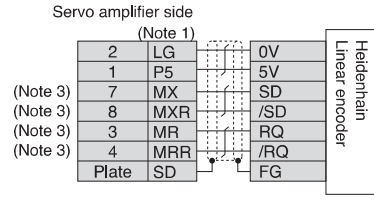
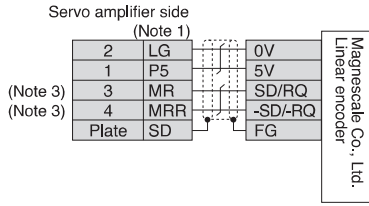
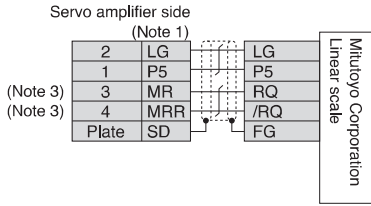

- Notes: 1. For the number of the wire pairs for LG and P5, refer to "Linear Encoder Instruction Manual."
 2. If the encoder's current consumption exceeds 350 mA, supply power from an external source.
 3. For CN2L connector, the signals of 3-pin, 4-pin, 7-pin, and 8-pin are as follows:
 3-pin: MR2
 4-pin: MRR2
 7-pin: MX2
 8-pin: MXR2



Be sure to read through Instruction Manual for the actual wiring and use. Use the equipment after you have a full knowledge of the equipment, safety information and instructions.

Servo Amplifiers

MR-J4-GF/MR-J4-GF-RJ Dimensions

GF GF-RJ

- MR-J4-60GF4, MR-J4-60GF4-RJ
- MR-J4-100GF4, MR-J4-100GF4-RJ

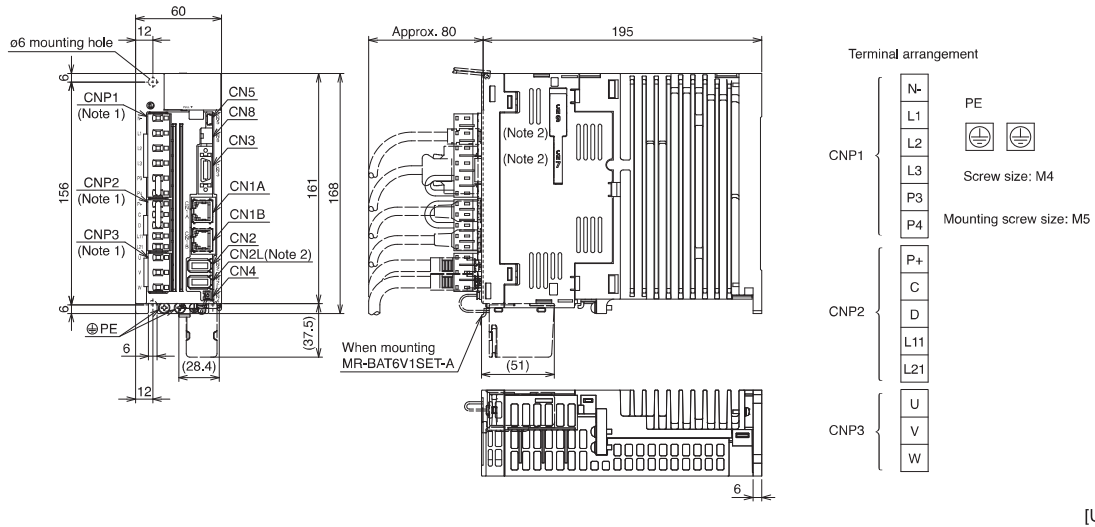

[Unit: mm]

- MR-J4-200GF, MR-J4-200GF-RJ

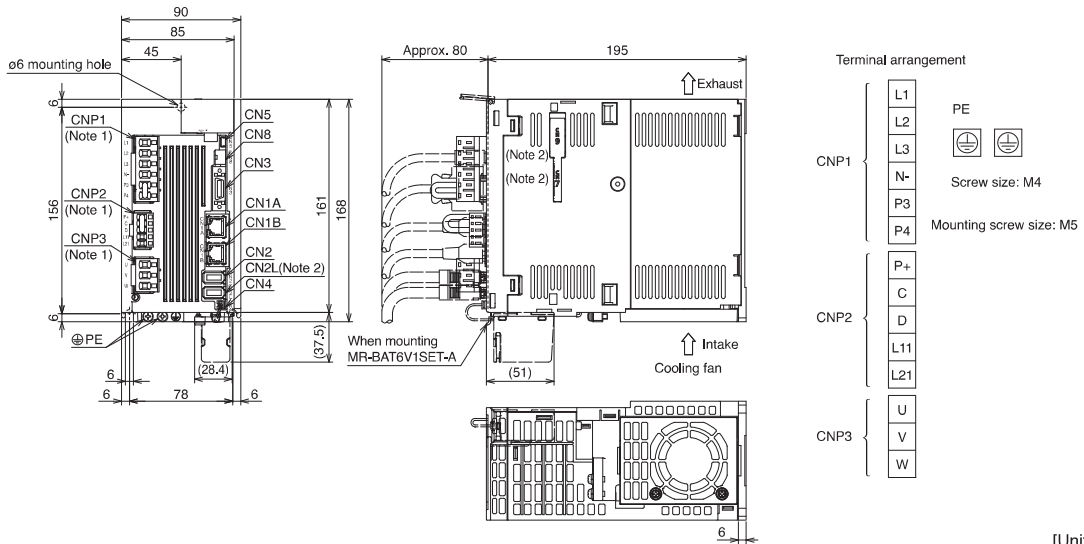

[Unit: mm]

- MR-J4-200GF4, MR-J4-200GF4-RJ

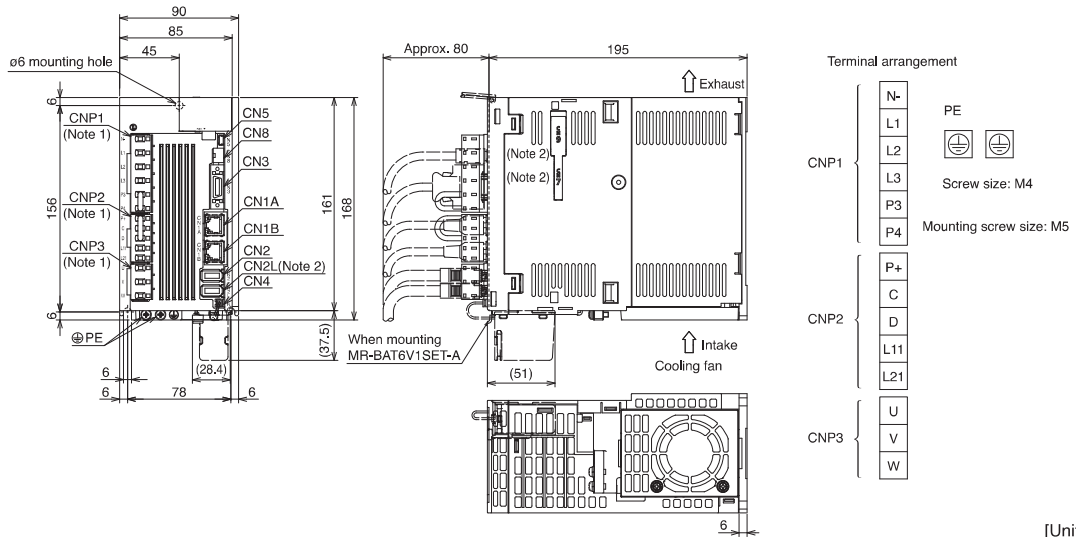

[Unit: mm]

Notes: 1. CNP1, CNP2 and CNP3 connectors are supplied with the servo amplifier.
 2. CN2L, CN7, and CN9 connectors are not available for MR-J4-GF servo amplifier.

MR-J4-GF/MR-J4-GF-RJ Dimensions

●MR-J4-350GF, MR-J4-350GF-RJ

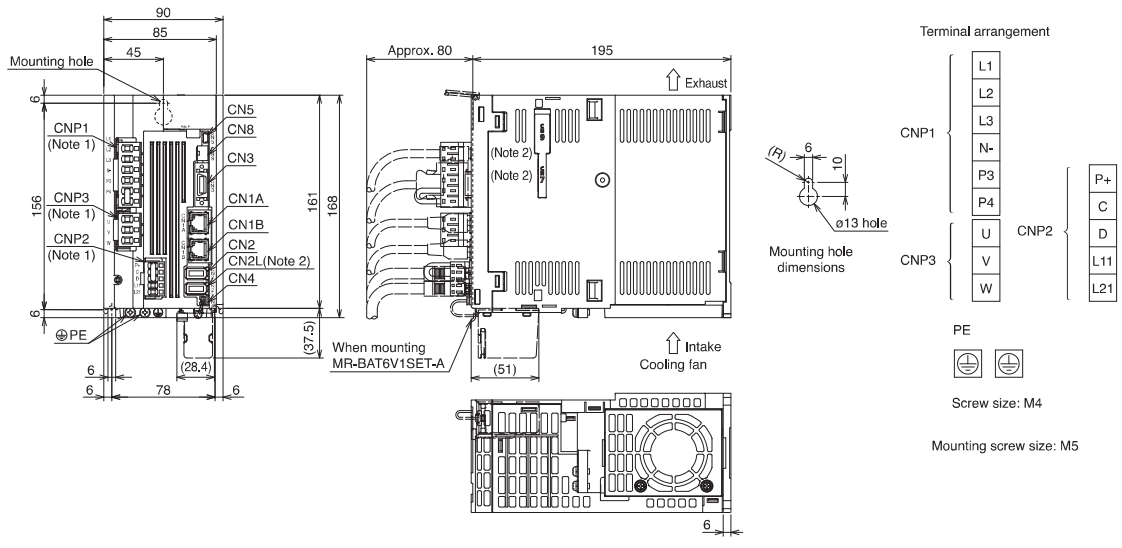

[Unit: mm]

●MR-J4-350GF4, MR-J4-350GF4-RJ

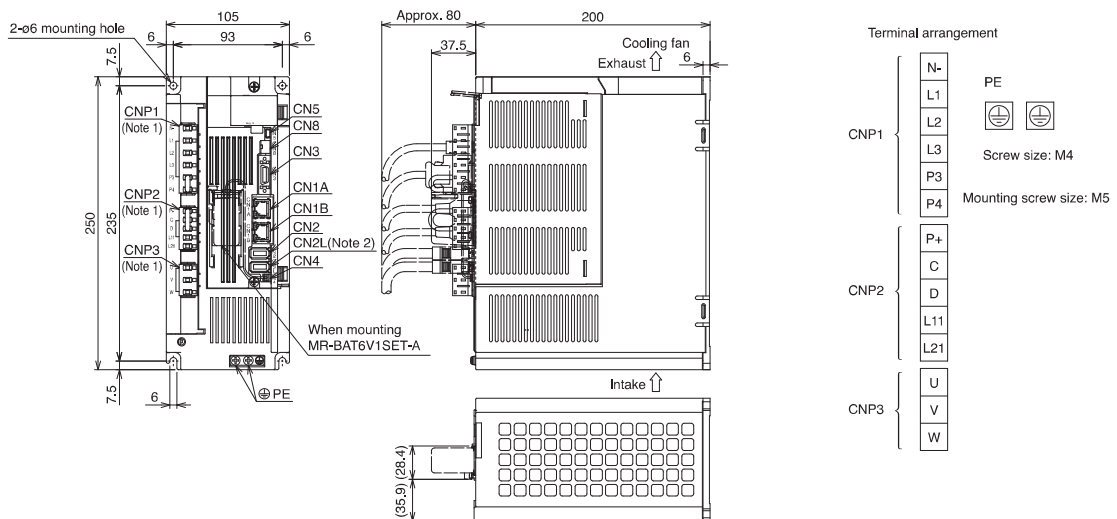

[Unit: mm]

●MR-J4-500GF, MR-J4-500GF-RJ

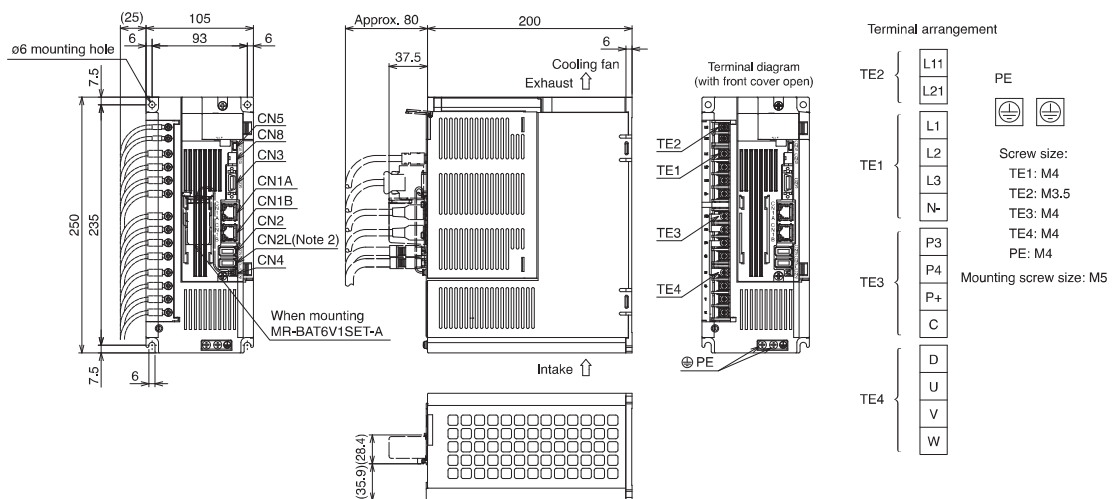

[Unit: mm]

Notes: 1. CNP1, CNP2 and CNP3 connectors are supplied with the servo amplifier.
2. CN2L, CN7, and CN9 connectors are not available for MR-J4-GF servo amplifier.

Servo Amplifiers

MR-J4-GF/MR-J4-GF-RJ Dimensions

GF GF-RJ

●MR-J4-500GF4, MR-J4-500GF4-RJ

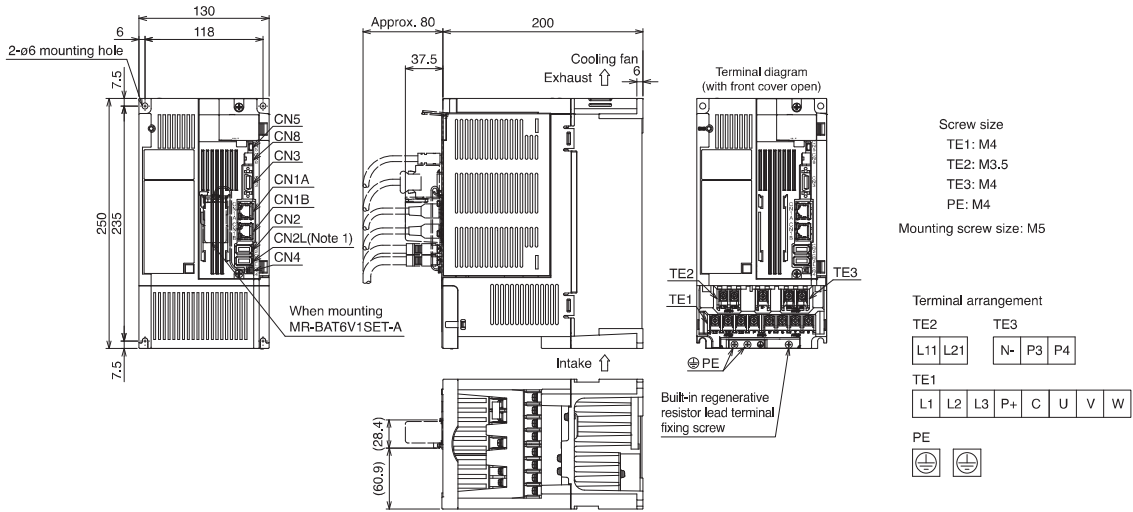

[Unit: mm]

●MR-J4-700GF, MR-J4-700GF-RJ

●MR-J4-700GF4, MR-J4-700GF4-RJ

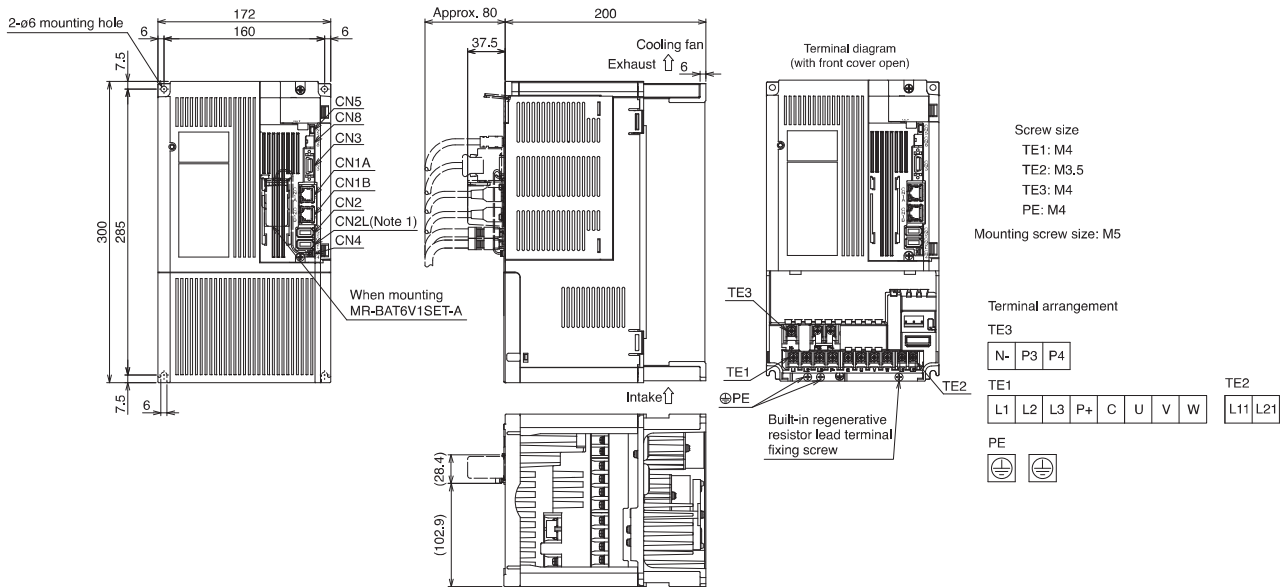

[Unit: mm]

Notes: 1. CN2L, CN7, and CN9 connectors are not available for MR-J4-GF servo amplifier.

MR-J4-GF/MR-J4-GF-RJ Dimensions

- MR-J4-11KGF, MR-J4-11KGF-RJ, MR-J4-11KGF4, MR-J4-11KGF4-RJ
- MR-J4-15KGF, MR-J4-15KGF-RJ, MR-J4-15KGF4, MR-J4-15KGF4-RJ

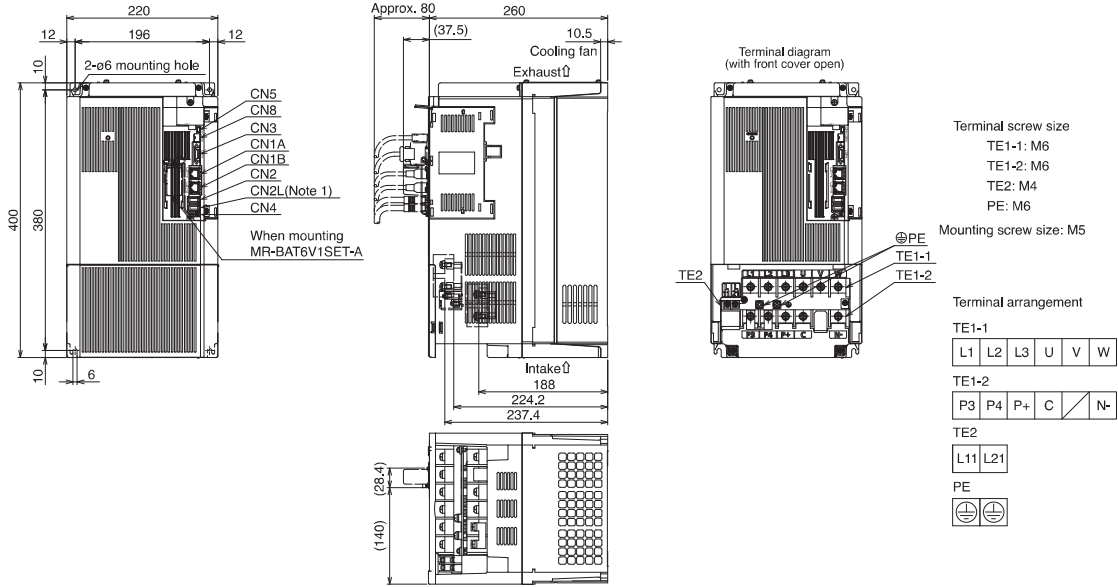

[Unit: mm]

- MR-J4-22KGF, MR-J4-22KGF-RJ, MR-J4-22KGF4, MR-J4-22KGF4-RJ

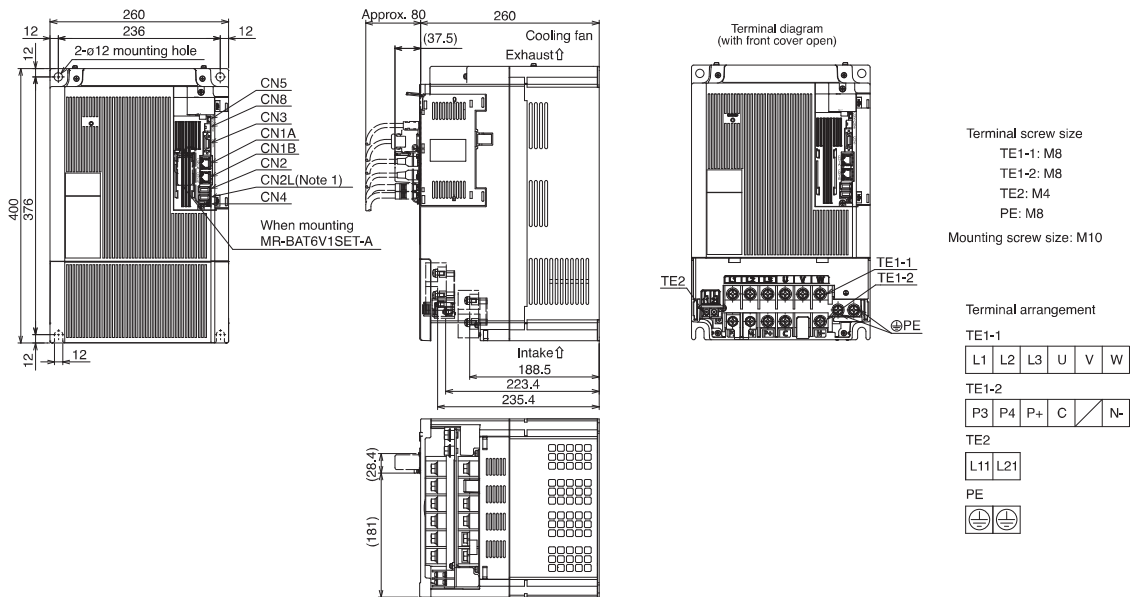

[Unit: mm]

Notes: 1. CN2L, CN7, and CN9 connectors are not available for MR-J4-GF servo amplifier.