

FUJI SERVO SYSTEM
ALPHA5





SIMPLE & SMART

ALPHA5

Line of products of ALPHA5 Series

Servo Amplifier

Model	Command interface				Control mode				Power supply	Capacity	Type	Applicable motor series	
	Pulse/analog	Di/Do	Modbus-RTU	SX bus	Positioning	Position	Speed	Torque					
 General-purpose interface	VV type	●	●	●		●	●	●	●	Single-phase or 3-phase 200 to 240 VAC	0.05 to 0.75kW	RYT***□5-VV2	GYS GYC GYG NEW GYB
										3-phase 200 to 240 VAC	0.85 to 5.0kW		
										Single-phase 100 to 120 VAC	0.05 to 0.375kW	RYT***□5-VV6	GYS
 High speed serial bus (SX bus)	VS type				●		●	●	●	Single-phase or 3-phase 200 to 240 VAC	0.05 to 0.75kW	RYT***□5-VS2 RYT***□5-LS2	GYS GYC GYG NEW GYB
	LS type									3-phase 200 to 240 VAC	0.85 to 5.0kW		
						●	●	●			Single-phase 100 to 120 VAC	0.05 to 0.375kW	RYT***□5-VS6 RYT***□5-LS6

CONTENTS

Features	2
Explanation of Model Codes	9
Specifications of Servo Amplifier	10
Connection Diagram (Reference)	13
Specifications of Servomotor	15
Option/Peripheral Equipment	22

External Dimensions	24
Model List	34
Service Network	38
Product Warranty	39

Next generation servo system for ever-evolving machines

Servomotor

Model	Rated speed (max. speed)	Power supply	Rated output capacity	Servomotor type		Protective construction	Encoder	Type
				Without brake	With brake			
 <p>GYS motor Ultra-low inertia</p>	3000r/min (0.75kW or less: 6000r/min 1.0kW or more: 5000r/min)	200V series	11 types 0.05 to 5.0kW	●	●	IP67 *1	18-bit ABS	GYG***D5-HB2(-B) *2
				●	●		20-bit INC	GYG***D5-RB2(-B) *2
		100V series	4 types 0.05 to 0.375kW	●	●	IP67 *1	18-bit ABS	GYG***D5-HB6(-B) *2
				●	●		20-bit INC	GYG***D5-RB6(-B) *2
 <p>GYC motor Low inertia</p>	3000r/min (0.75kW or less: 6000r/min 1.0kW or more: 5000r/min)	200V series	7 types 0.1 to 2.0kW	●	●	IP67 *1	18-bit ABS	GYC***D5-HB2(-B) *2
				●	●		20-bit INC	GYC***D5-RB2(-B) *2
 <p>GYG motor Medium inertia</p>	2000r/min (3000r/min)	200V series	5 types 0.5 to 2.0kW	●	●	IP67 *1	18-bit ABS	GYG***C5-HB2(-B) *2
				●	●		20-bit INC	GYG***C5-RB2(-B) *2
 <p>GYG motor Medium inertia</p>	1500r/min (3000r/min)	200V series	3 types 0.5, 0.85, 1.3kW	●	●	IP67 *1	18-bit ABS	GYG***B5-HB2(-B) *2
				●	●		20-bit INC	GYG***B5-RB2(-B) *2
 <p>GYB motor Medium inertia</p>	3000r/min (6000r/min*3)	200V series	3 types 0.2, 0.4, 0.75kW	●	●	IP67 *1	18-bit ABS	GYG***D5-HB2(-B) *2
				●	●		20-bit INC	GYG***D5-RB2(-B) *2

*1: Except for shaft-through part (Also except connectors for GYS and GYC motors of 0.75kW or less and all GYB motors).

*2: Models with a brake has "-B" at the end.

*3: The maximum rotation speed is 5000r/min when using the motor with Fuji's gear head.

Compatibility with general-purpose communication: VV type

Simple! PTP positioning

Positioning function is embedded as standard in general purpose interface unit "ALPHA5 VV".

As the ALPHA5 VV type is the standard model, external positioning unit or dedicated items for positioning are not required.

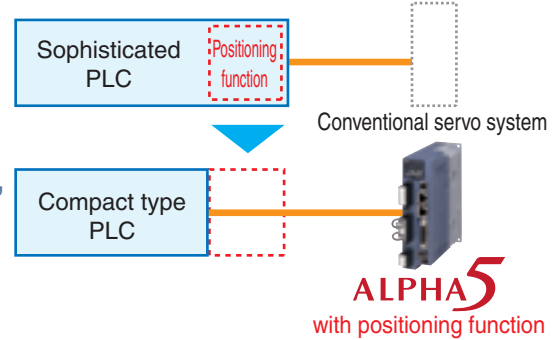

3 in 1 !

Following operations are enabled by one unit:

- Positioning via Modbus-RTU communications (immediate value data)
- Positioning via Di/Do signal (positioning data 15 points*)
- Controlling positions, speeds and torques via pulse/analog input

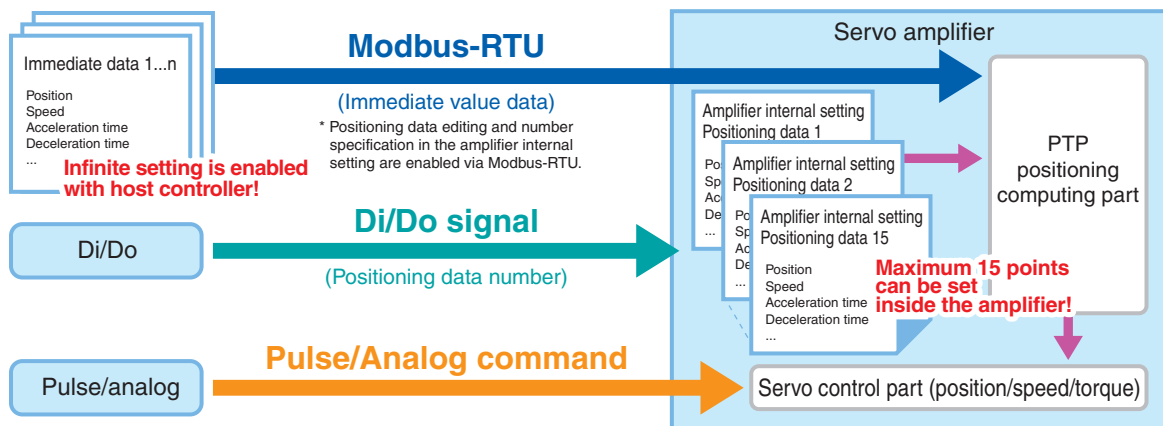

Simple connection! Modbus-RTU communications

Operations such as PTP positioning operation, parameter edit, and various monitoring are enabled. All you need to do is connect HMI (POD), general-purpose PLC, or PC controller directly to servo amplifier via Modbus-RTU communications.

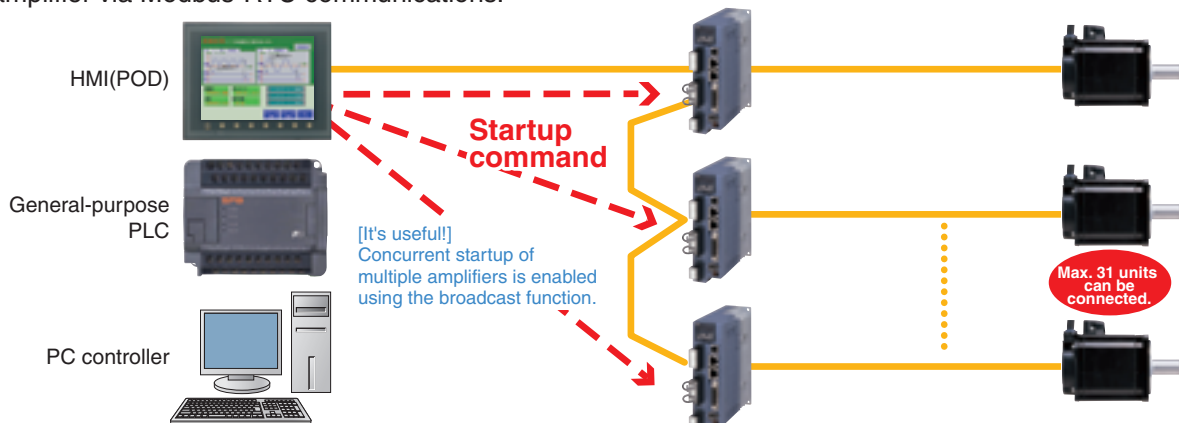

Other makers' products compatible with Modbus-RTU

Any HMI (POD), general-purpose PLC, or PC controller compatible with Modbus-RTU can be connected to servo amplifier easily regardless of maker.

Compatibility with SX bus: VS type and LS type

Sophisticated motion control system that has synchronization and interpolation controls can be configured easily.

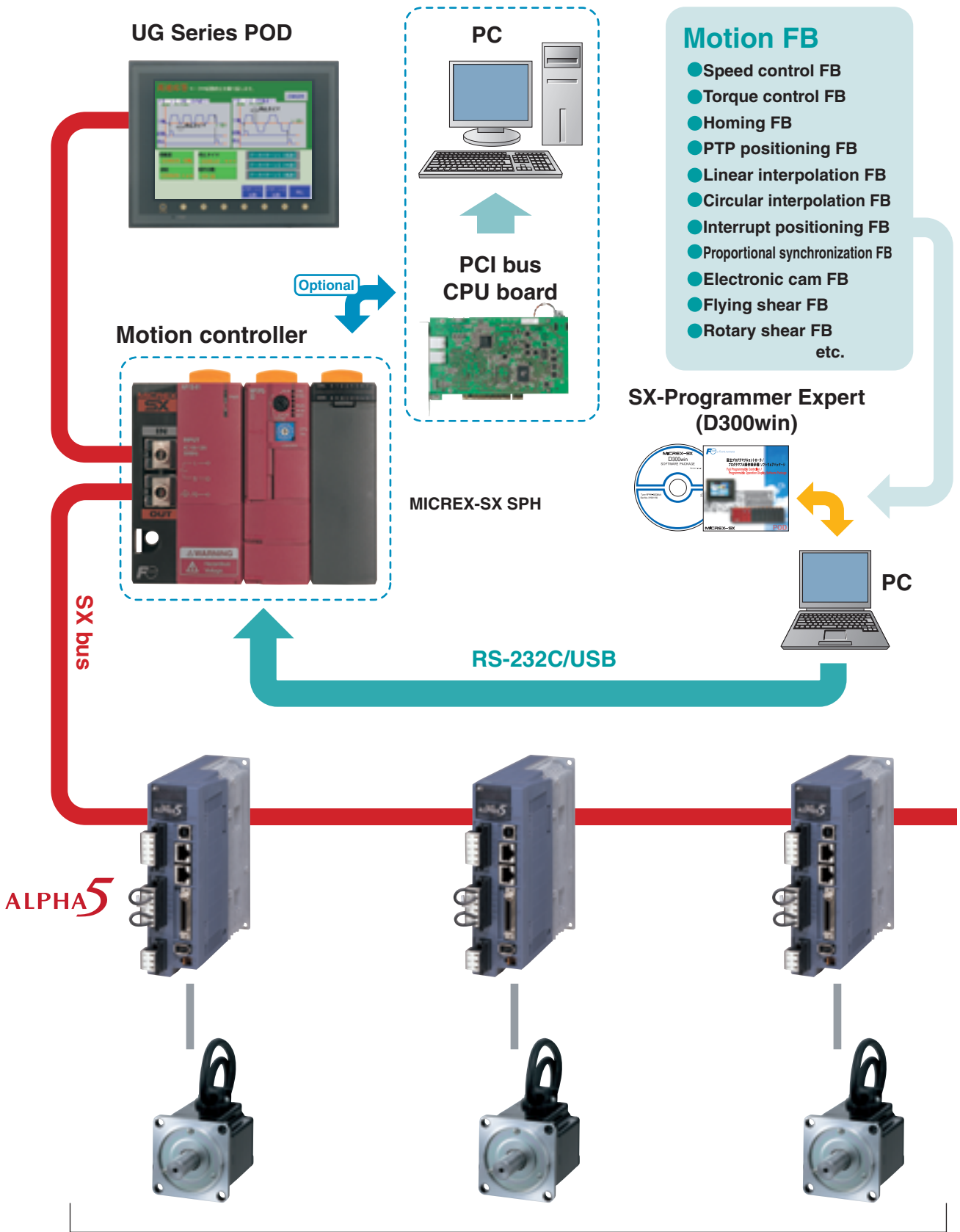

- ### Motion FB
- Speed control FB
 - Torque control FB
 - Homing FB
 - PTP positioning FB
 - Linear interpolation FB
 - Circular interpolation FB
 - Interrupt positioning FB
 - Proportional synchronization FB
 - Electronic cam FB
 - Flying shear FB
 - Rotary shear FB etc.

SX-Programmer Expert (D300win)



ALPHA5

Total extension 25m (maximum), 32 connection units (maximum)

Fast and accurate positioning is realized.

New high speed servo control engine
Frequency response 1500Hz

Increased motor rotation speed
Max. rotation speed 6000r/min

Fine resolution encoder
18-bit absolute 262,144 pulses
20-bit incremental 1,048,576 pulses

High performance frequency response (1500Hz), high rotation speed (6000r/min) and high resolution encoder reduce the cycle time and make faster and more accurate positioning and settling possible.

■ Cycle time reduction 1.2s → 1s

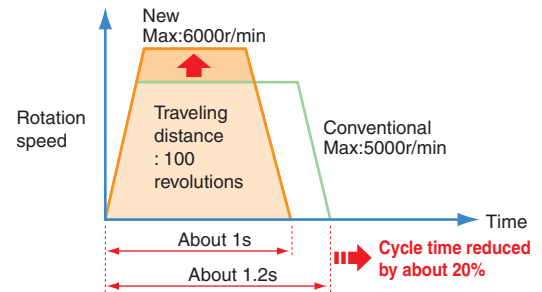

■ Time necessary to settling to 1 μ m accuracy 4ms

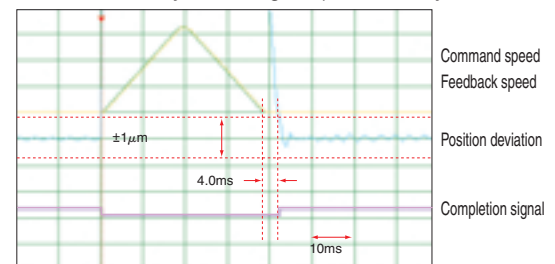

1/10000 rotation accuracy with a 10mm ball screw = 1 μ m

New control functions

New notch filter (auto notch filter)

The notch filter is set automatically upon detection of mechanical resonance. Because detection and calculation are always conducted while the auto notch filter remains turned on, resonance frequencies changing by time are effectively filtered.

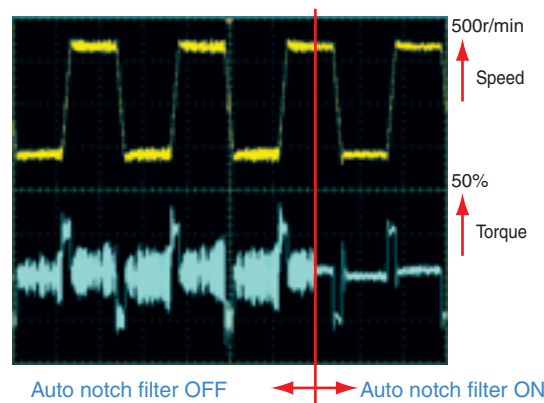
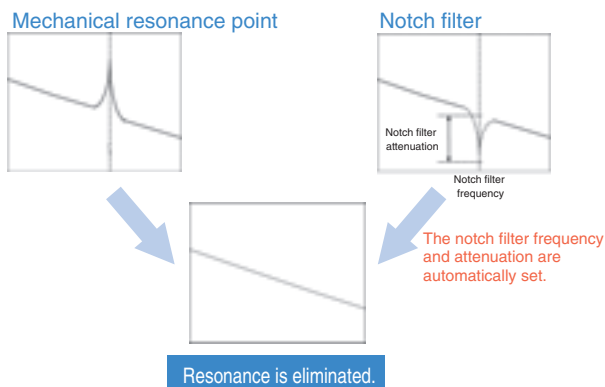

Homing by hit-to-stop

Wire saving can be achieved with elimination of the limit switch and over travel signal. Moreover, several homing functions allows homing program creation to be simplified only by combining the servo parameters. Creating complicated program of homing in the host controller is no more necessary.

Motor stop method setting is enabled

- Alarm occurrence
 - Main power supply is OFF.
 - Servo ON signal is OFF.
- Selection among rapid deceleration stop, DB stop, and coast-to-stop is enabled under the above conditions. Since limiting output torque at desired value is possible even if rapid deceleration stops is selected, impact shock to the machine can be reduced.

* However, it is enabled when the control power supply is input.

Reduced space

Size reduction of servomotor and servo amplifier

- Servo amplifier

The installation area is reduced by 25 to 30% when compared with our conventional model.

- Servomotor

The overall length is reduced by about 15% when compared with our conventional model.

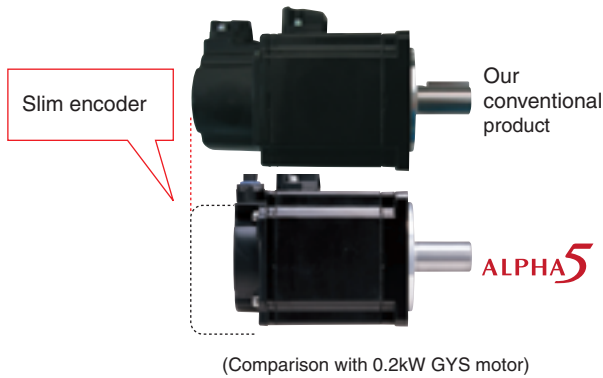

Close installation

The servo amplifier can be installed side by side without a clearance. The installation space in the control panel of the machine is reduced.

* 80% ED rating in case of close installation
There is no limitation if 5mm or a larger clearance is placed.



Close installation can be made even if the ABS backup battery is installed. The battery can be replaced without difficulty while the servo amplifier is left installed.



The designed life time of the battery is about 35000 hours. (Retention time with power turned off)



Long life design

The designed service lives of various parts of the servo amplifier are extended.

Electrolytic capacitor: 10 years

Cooling fan: 10 years

* Operating conditions

- Ambient temperature: Average 30°C/year
- Load factor: Within 80%
- Operation ratio: Within 20 hours/day

Compliance with various standards

Compliance with CE marking and UL/cUL and TÜV

Global Compatibility. The standard model complies with CE marking, UL/cUL and TÜV.



* As for UL/cUL, some of the models are in the process to be certified.

Compliance with RoHS directive

The standard model complies with EU's specific hazardous material limitation (RoHS) directive. The servo system is environmentally friendly because use of six hazardous materials is limited.

<Six hazardous materials>

Lead, mercury, cadmium, hexavalent chromium, polybrominated biphenyl (PBB), polybrominated diphenylether (PBDE)

Environmental resistance

IP67 (servomotor)

The standard servomotor model is compatible with IP67* and it can be used in the environment susceptible to water or dust splashes.

* Except for shaft-through part and connectors

Compatibility

Compatibility with FALDIC- α , - β and -W motors

Because compatibility with FALDIC- α , - β and -W Series servomotors is assured, the new amplifier meets requirements for replacement of existing products flexibly. (Compatibility with individual products is planned.)



Improved usability: PC Loader

USB connection

The amplifier can be connected to PC using a commercially available USB cable (B-type).

Simple setup

- Easy tuning and profile operation

Because the servo can be adjusted for the machine even if the controller program is not completed, the machine setup time is substantially reduced.

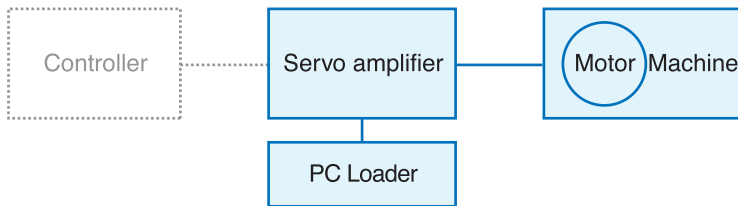

Easy tuning data entry screen



Up to 25 reciprocal motions of the servomotor are conducted while the gain is automatically adjusted.

- Sequence test mode

The controller program can run even if the machine is not completed. The efficiency of program debugging is improved.

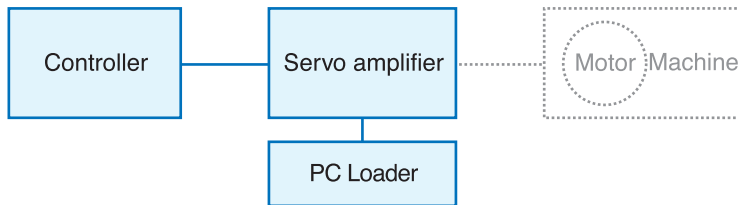

Sequence test mode data entry screen



The sequence of the host controller can be tested even if the servomotor is not connected.

Enriched maintenance functions

- Functions associated with alarm

When an alarm occurs, data such as the speed and torque at alarm occurrence is displayed as well as the description of the alarm. Accurate analyses into the cause of the alarm are possible.

Description of the alarm and various cumulative operation times are displayed.

Alarm history monitor screen

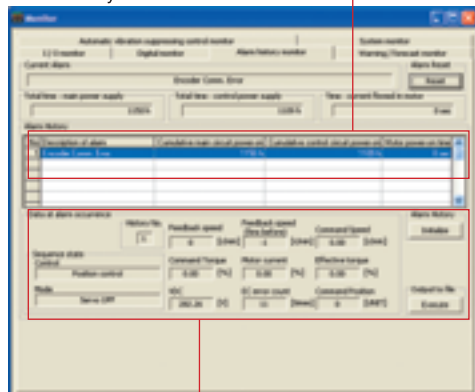

Each piece of data at alarm occurrence is displayed.

- Life warning function

The life of consumable parts of the servo amplifier is calculated.

- Battery life warning
- Main circuit capacity life warning
- Cooling fan life warning

Warning monitor screen

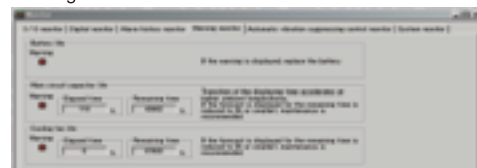

The warning can be issued in a sequence output signal or displayed on the keypad.

Explanation of Model Codes

Servo amplifier

RYT 500 D 5 - V S 2

Code	[Basic type]
RYT	ALPHA5 series

Code	[Applicable motor output]
500	50 × 10 ⁰ = 0.05kW
101	10 × 10 ¹ = 0.1kW
201	20 × 10 ¹ = 0.2kW
401	40 × 10 ¹ = 0.4kW, 0.375kW
501	50 × 10 ¹ = 0.5kW
751	75 × 10 ¹ = 0.75kW
851	85 × 10 ¹ = 0.85kW
102	10 × 10 ² = 1.0kW
132	13 × 10 ² = 1.3kW
152	15 × 10 ² = 1.5kW
202	20 × 10 ² = 2.0kW
302	30 × 10 ² = 3.0kW
402	40 × 10 ² = 4.0kW
502	50 × 10 ² = 5.0kW

Code	[Series]
D	3000r/min series
C	2000r/min series
B	1500r/min series

Code	[Order of development]
5	5

Code	[Input voltage]
2	3-phase 200 VAC
6	Single-phase 100 VAC

Code	[Upper interface]
S	SX bus
V	General-purpose interface (pulse, analog voltage)

Code	[Major functions]
V	Position, speed and torque control
L	Built-in positioning function

Servomotor

GYS 500 D 5 - H B 2 - B

Code	[Basic type]
GYS	Ultra-low inertia
GYC	Low inertia
GYG	Medium inertia
GYB	Medium inertia

Code	[Rated output]
500	50 × 10 ⁰ = 0.05kW
101	10 × 10 ¹ = 0.1kW
201	20 × 10 ¹ = 0.2kW
401	40 × 10 ¹ = 0.4kW, 0.375kW
501	50 × 10 ¹ = 0.5kW
751	75 × 10 ¹ = 0.75kW
851	85 × 10 ¹ = 0.85kW
102	10 × 10 ² = 1.0kW
132	13 × 10 ² = 1.3kW
152	15 × 10 ² = 1.5kW
202	20 × 10 ² = 2.0kW
302	30 × 10 ² = 3.0kW
402	40 × 10 ² = 4.0kW
502	50 × 10 ² = 5.0kW

Code	[Rated speed]
D	3000r/min series
C	2000r/min series
B	1500r/min series

Code	[Order of development]
5	5

Code	[Brake]
Blank	Not provided
B	Provided

Code	[Input voltage]
2	3-phase 200 VAC
6	Single-phase 100 VAC

Code	[Oil seal/shaft]
A	Without an oil seal, straight shaft with a key
B	Without an oil seal, straight shaft without a key
C	Without an oil seal, straight shaft with a key, tapped
E	With an oil seal, straight shaft with a key
F	With an oil seal, straight shaft without a key
G	With an oil seal, straight shaft with a key, tapped

Code	[Encoder]
H	18-bit ABS
R	20-bit INC

Specifications of Servo Amplifier

Common specifications

Applicable motor rated speed		3000r/min				3000r/min										2000r/min					1500r/min																										
Applicable motor output [kW]		0.05	0.1	0.2	0.375	0.05	0.1	0.2	0.4	0.75	1.0	1.5	2.0	3.0	4.0	5.0	0.5	0.75	1.0	1.5	2.0	0.5	0.85	1.3																							
Amplifier type		D5-△△○				500				101		201		401		751		102		152		202		302		402		502																			
RYT□□□		C5-△△2																																													
		B5-△△2																																													
Outer frame number		Frame 1		Frame 2		Frame 3		Frame 1		Frame 2		Frame 3		Frame 4		Frame 5		Frame 6		Frame 3		Frame 4		Frame 5		Frame 3		Frame 4		Frame 5																	
Mass [kg]		0.9		1.1		1.3		0.9		1.1		1.3		1.5		2.6		3.8		1.3		1.5		2.9		1.3		1.5		2.9																	
Protective construction / cooling		Open / self-cooling		Open / forced air cooling		Open / self-cooling		Open / self-cooling		Open / self-cooling		Open / forced air cooling		Open / forced air cooling		Open / forced air cooling		Open / forced air cooling		Open / forced air cooling		Open / forced air cooling		Open / forced air cooling		Open / forced air cooling		Open / forced air cooling																			
Power supply	Main power supply		Phase		Single-phase		Single-phase, 3-phase		3-phase		3-phase		Single-phase, 3-phase		3-phase		Single-phase, 3-phase		3-phase		Single-phase, 3-phase		3-phase		Single-phase, 3-phase		3-phase																				
	Voltage frequency		AC100 to 120V 50/60Hz		AC200 to 240V 50/60Hz		AC200 to 240V 50/60Hz		AC200 to 240V 50/60Hz		AC200 to 240V 50/60Hz		AC200 to 240V 50/60Hz		AC200 to 240V 50/60Hz		AC200 to 240V 50/60Hz		AC200 to 240V 50/60Hz		AC200 to 240V 50/60Hz		AC200 to 240V 50/60Hz		AC200 to 240V 50/60Hz		AC200 to 240V 50/60Hz																				
	Allowable voltage fluctuation		AC85 to 132V		AC85 to 132V		AC85 to 132V		AC85 to 132V		AC85 to 132V		AC85 to 132V		AC85 to 132V		AC85 to 132V		AC85 to 132V		AC85 to 132V		AC85 to 132V		AC85 to 132V		AC85 to 132V		AC85 to 132V																		
	Control power supply		Phase		Single-phase		Single-phase		Single-phase		Single-phase		Single-phase		Single-phase		Single-phase		Single-phase		Single-phase		Single-phase		Single-phase		Single-phase		Single-phase																		
Voltage frequency		AC100 to 120V 50/60Hz		AC100 to 120V 50/60Hz		AC100 to 120V 50/60Hz		AC100 to 120V 50/60Hz		AC100 to 120V 50/60Hz		AC100 to 120V 50/60Hz		AC100 to 120V 50/60Hz		AC100 to 120V 50/60Hz		AC100 to 120V 50/60Hz		AC100 to 120V 50/60Hz		AC100 to 120V 50/60Hz		AC100 to 120V 50/60Hz		AC100 to 120V 50/60Hz		AC100 to 120V 50/60Hz																			
Allowable voltage fluctuation		AC85 to 132V		AC85 to 132V		AC85 to 132V		AC85 to 132V		AC85 to 132V		AC85 to 132V		AC85 to 132V		AC85 to 132V		AC85 to 132V		AC85 to 132V		AC85 to 132V		AC85 to 132V		AC85 to 132V		AC85 to 132V																			
Control system		IGBT PWM sinusoidal PWM drive																																													
Max voltage for regenerative resistance [W]		Built-in resistor		-		8		20		-		-		8		20		20		20		30		30		60		60		20		20		20		30		30		20		20		30			
External resistor *1		17		17		25		25		17		17		17		17		50		50		50		260		260		300		300		50		50		50		260		260		50		50		260	
Dynamic brake		Built-in *2																																													
Feedback		18-bit serial encoder (absolute/incremental), 20-bit serial encoder (incremental)																																													
Overload capability		300% / 3 sec.																																													
Speed fluctuation ratio	Load fluctuation		Within ±1 r/min (load fluctuation 0 to 100%)																																												
	Power supply fluctuation		Within ±1 r/min (power supply fluctuation -10 to +10%)																																												
	Temperature fluctuation		Within ±0.2% (25 ±10°C at rated operation speed and analog input operation)																																												
Capability and function	VV type	Speed control function		Closed loop control with speed adjuster, acceleration/deceleration time setting, manual feed rate/max. rotation speed, speed command zero clamp, etc.																																											
		Position control function		15-point (position, speed, acceleration/deceleration time setting, timer, M code and various statuses)																																											
		Torque control function		Closed loop control with position adjuster, electronic gear, output pulse setting, feed forward, homing, interrupt positioning, auto startup, etc.																																											
		Accessory functions		Closed loop control with current adjuster (proportional open loop control of current and torque), torque limit, speed limit at torque control, etc.																																											
	VS type	Speed control function		Easy tuning, profile operation, sequence test mode, auto tuning, auto notch filter, vibration suppressing online learning, etc.																																											
		Position control function		Closed loop control with speed adjuster, acceleration/deceleration time setting, manual feed rate/max. rotation speed, etc.																																											
		Torque control function		Closed loop control with position adjuster, electronic gear, output pulse setting, feed forward, homing, interrupt positioning, etc.																																											
		Accessory functions		Closed loop control with current adjuster (proportional open loop control of current and torque), torque limit, speed limit at torque control, etc.																																											
	LS type	Speed control function		Easy tuning, profile operation, sequence test mode, auto tuning, auto notch filter, vibration suppressing online learning, etc.																																											
		Position control function		Automatic startup, manual operation, pulse train, homing																																											
		Number of position data sets		99-point (position, speed, timer, M code and various statuses)																																											
		Max positioning value		±2,000,000,000																																											
Positioning method		Absolute / incremental																																													
Accessory functions		Easy tuning, profile operation, sequence test mode, auto tuning, auto notch filter, vibration suppressing online learning, etc.																																													
Protective function (Alarm indication)		Overcurrent(oc1, oc2), Overspeed(oS), Control power undervoltage(Lvc), Overvoltage(Hv), Encoder trouble(Et1, Et2), Circuit trouble(ct), Memory Error(dE), Fuse Broken(Fb), Motor Combination Error(cE), Braking transistor overheat(tH), Encoder Communication error(Ec), CONT(Control signal) Error(ctE), Overload(oL1, oL2), Main power undervoltage(LVP), Braking resistor overheat(rH1, rH2, rH3), Deviation overflow(oF), Amplifier overheat(AH), Encoder overheat(EH), Absolute data Lost(dL1, dL2, dL3), Multi-turn data over flow(AF), Initial Error(IE), Command pulse Frequency Error(HF)																																													
Operation and display section of main body (keypad)		6-digit alphanumeric display with 7-segment LED 4 operation switches Analog monitor connector (CN6), status indication LED																																													
Working conditions	Installation place		Indoors (free from direct sunshine), altitude ≤ 1000m, free from corrosive and flammable gases, oil mist and dust In case of compliance with CE marking Models compliant with EU directive: pollution degree 2, over voltage category III																																												
	Temperature/humidity		-10 to 55°C/10 to 90%RH (without condensation)																																												
	Vibration / shock resistance		4.9m/s²/19.6m/s²																																												
Standards		UL/cUL (UL508c), CE marking (low voltage directive EN61800-5-1) (acquisition being applied for model of 2.0kW or more), RoHS directive																																													

*1: The figure is data determined when the amplifier is connected with an external resistor dedicated for each model.

*2: We will accept custom orders for models without dynamic brake.

Specifications of Servo Amplifier

VV Type

Outline of system configuration

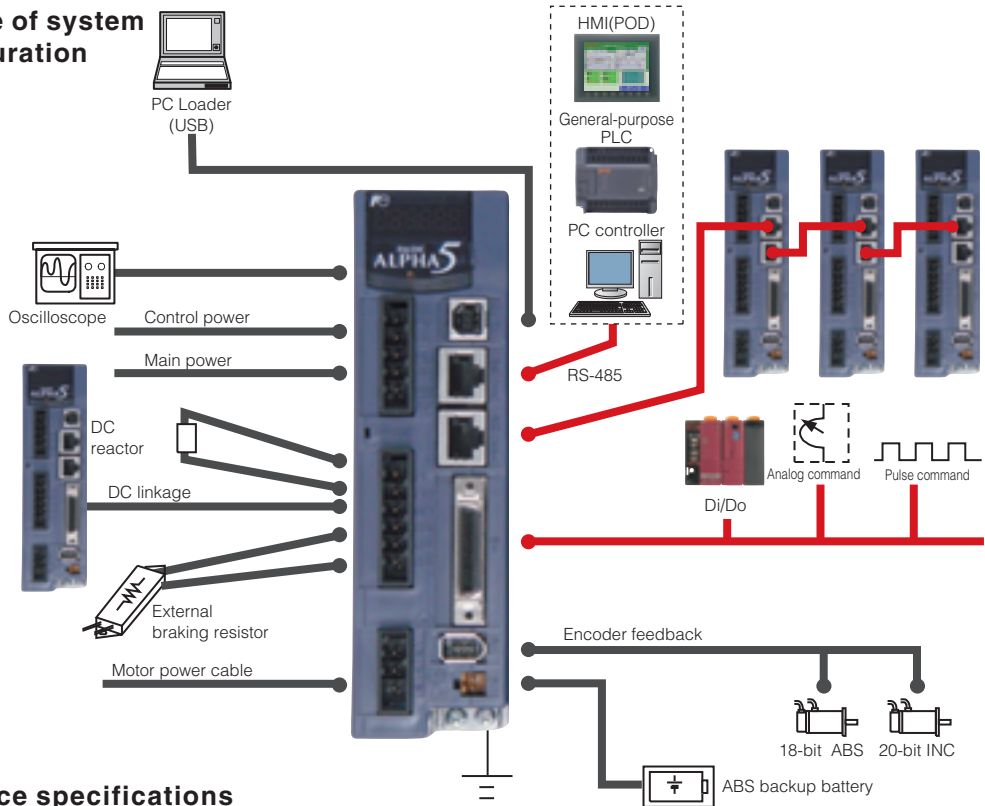

Interface specifications

Item	Specifications	
Command interface	Positioning function	RS-485 (Modbus-RTU), Di/Do
	Position control	Pulse input
	Speed control	Analog voltage input
	Torque control	Analog voltage input
Communication interface	Two RS-485 ports (for parameter editing and monitor)	
	Our original protocol Modbus-RTU	
	9600/19200/38400 bps, connection of max. 31 axes	

Terminal name	Symbol	Specifications
Pulse input	CA,*CA CB,*CB	Pulse input under position control Differential input: max. input frequency $\leq 1.0\text{MHz}$ Open collector input: max. input frequency $\leq 200\text{kHz}$ (in case of signals at 90-degree phase difference, the above relationship is true for the four-fold frequency.) Pulse format Command pulse/Command direction Forward/Reverse pulse Two signals at 90-degree phase difference } Select one of these formats with a parameter setting.
	PPI	
Pulse output	FFA,*FFA FFB,*FFB	Differential output: max. output frequency $\leq 1\text{MHz}$ Two signals at 90-degree phase difference Pulse output count setting n pulses/rev): $16 \leq n \leq 262144$
	FFZ,*FFZ	
	FZ	Open collector output: 1 pulse/rev
	M5	Reference potential (0V)
Analog monitor voltage output	MON1 MON2	0V to $\pm 10\text{VDC}$ Resolution: 14bits / \pm full scale The output data depends on internal parameter.
	M5	Reference potential (0V)
Common for sequence I/O	COMIN	Common for sequence input signal
	COMOUT	Common for sequence output signal
Sequence input signal	CONT1 to CONT8	ON upon short circuit across contacts, OFF upon open circuit 12VDC-10% to 24VDC+10% Current consumption 20mA (per contact; used at 24VDC circuit voltage) Function of each signal depends on parameter setting Compatible with both sink and source input methods
Sequence output signal	OUT1 to OUT5	Short circuit upon ON, open circuit upon OFF 30VDC / 50mA (max.) Function of each signal depends on parameter setting Compatible with both sink and source output methods
Analog voltage input	VREF	Speed command input for speed control Input range: from -10 to 0 to -10V, input impedance 20k Ω Resolution: 15 bits / \pm full scale
	TREF	Torque command input for torque control Input range: from -10 to 0 to +10V, input impedance 20k Ω Resolution: 14 bits / \pm full scale
	P10	Power supply output for analog command (+10 VDC), output capacity 30 mA
	M5	Reference potential (0V)

Specifications of Servo Amplifier

Specifications of Servo Amplifier

VS Type, LS Type

Outline of system configuration

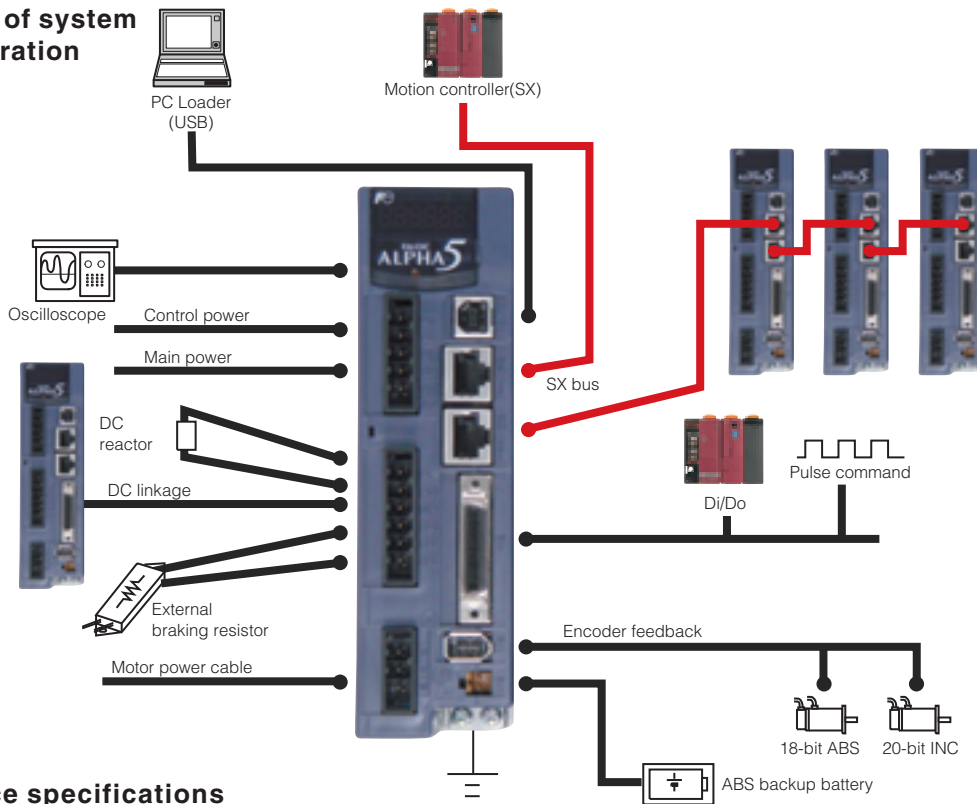

Interface specifications

Item	Specifications	
Command interface	Position control	SX bus: IQ area
	Speed control	SX bus: IQ area
	Torque control	SX bus: IQ area
Communication interface	SX bus (for command interface, parameter editing and monitor)	
	Our original protocol	
	25Mbps, connection of max. 32 axes	

Terminal name	Symbol	Specifications
Pulse input	CA,*CA CB,*CB	Pulse input during operation with high speed counter function (VS Type), Pulse train command input for position control (LS Type) Differential input: max. input frequency $\leq 1.0\text{MHz}$ Open collector input: max. input frequency $\leq 200\text{kHz}$ (In case of signals at 90-degree phase difference, the above relationship is true for the four-fold frequency.) Pulse format Command pulse/Command direction Forward/Reverse pulse Two signals at 90-degree phase difference } Select one of these formats with a parameter setting.
	PPI	Pull-up power input at open collector input ($24\text{VDC} \pm 10\%$)
Pulse output	FFA,*FFA FFB,*FFB	Differential output: max. output frequency $\leq 1\text{MHz}$ Two signals at 90-degree phase difference Pulse output count setting (n pulses/rev): $16 \leq n \leq 262144$
	FFZ,*FFZ	Differential output 1 pulse/rev
	FZ	Open collector output 1 pulse/rev
	M5	Reference potential (0V)
Analog monitor voltage output	MON1 MON2	0V to $\pm 10\text{VDC}$ Resolution: 14 bits / \pm full scale The output data depends on the internal parameter.
	M5	Reference potential (0V)
	COMIN COMOUT	Common for sequence input signal Common for sequence output signal
Sequence input signal	CONT1 to CONT5	ON upon short circuit across contacts, OFF upon open circuit $12\text{VDC} - 10\%$ to $24\text{VDC} + 10\%$ Current consumption 20mA (per contact; use at circuit voltage 24 VDC) Function of each signal depends on parameter setting Compatible with both sink and source input methods
Sequence output signal	OUT1 to OUT2	Short circuit upon ON, open circuit upon OFF 30VDC / 50mA (max.) Function of each signal depends on parameter setting Compatible with both sink and source output methods

Specifications of Servo Amplifier

Connection Diagram (Reference)

VV type

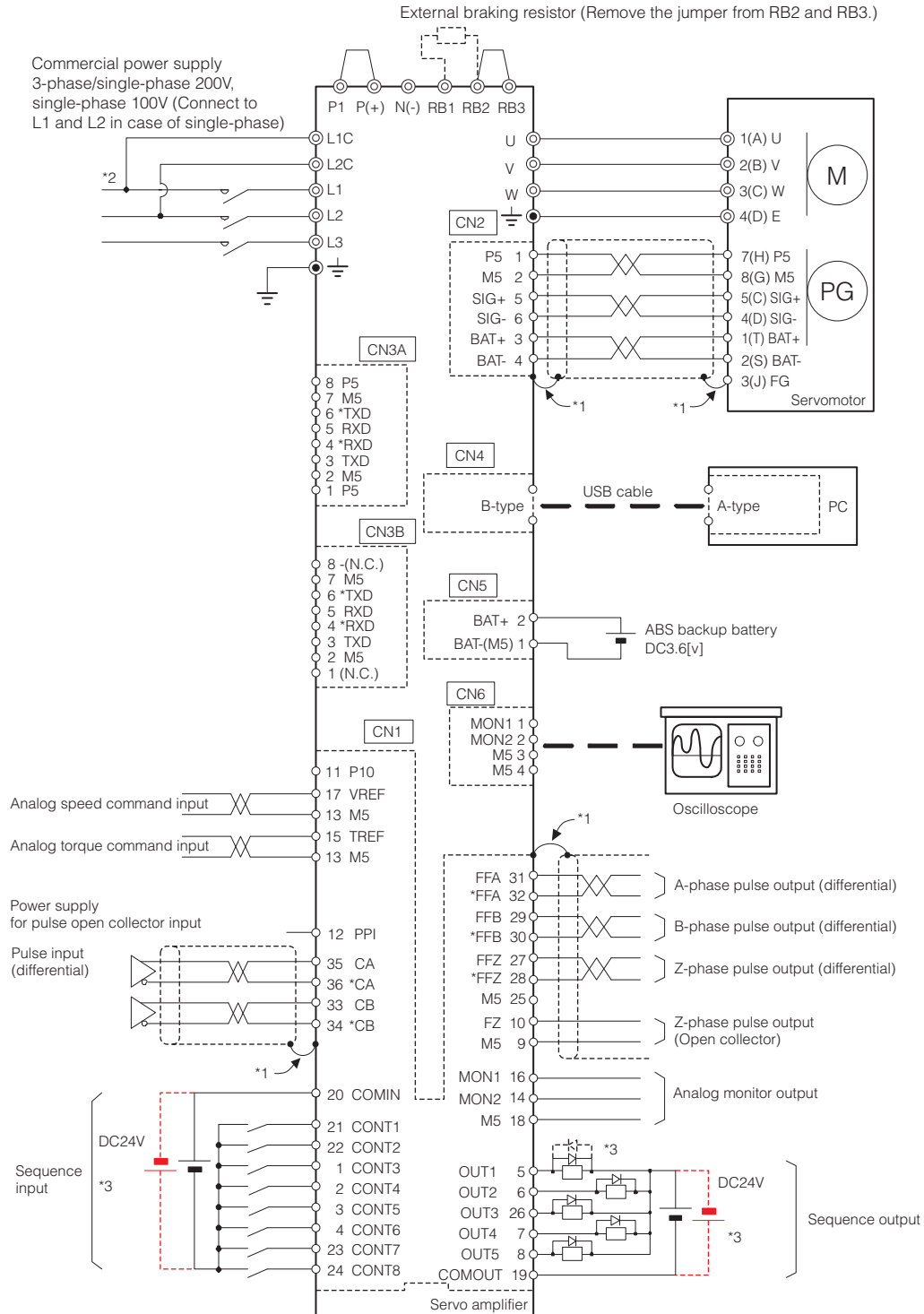

*1: Connect the shield to the connector shell of CN1 and CN2. The connector shell is at the ground potential (FG).

*2: Supply the control power (L1c and L2c) without fail. (The servo amplifier does not function with merely the main power supply.)

*3: To use in the source I/O, connect as shown with the broken line. Connect the surge absorber diode of the output load with the reverse polarity.



Caution

The diagram shown above is given as a reference for model selection.
When actually using the selected servo system, make wiring connections according to the connection diagram and instructions described in the user's manual.

Connection Diagram (Reference)

VS type, LS type

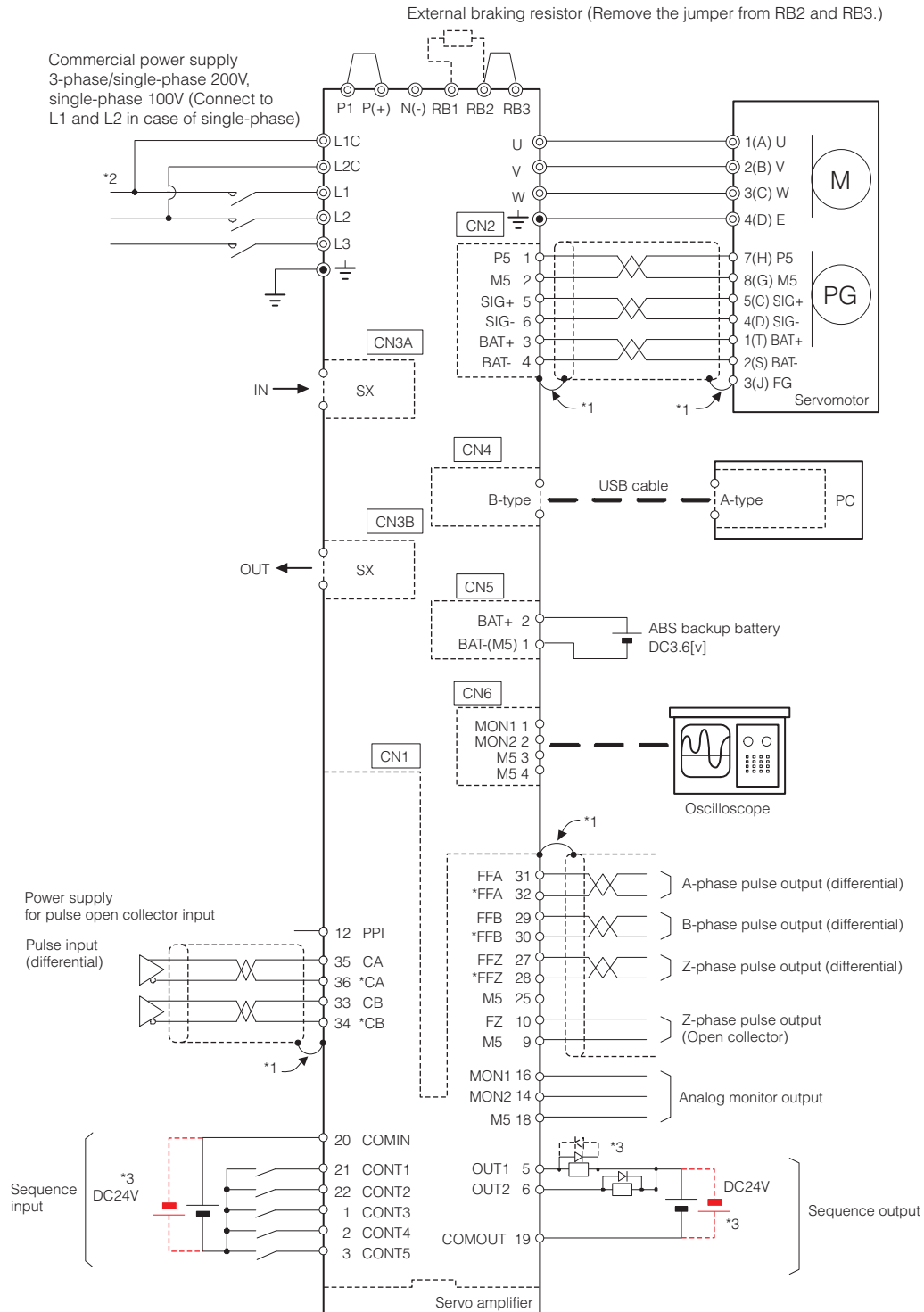

*1: Connect the shield to the connector shell of CN1 and CN2. The connector shell is at the ground potential (FG).

*2: Supply the control power (L1c and L2c) without fail. (The servo amplifier does not function with merely the main power supply.)

*3: To use in the source I/O, connect as shown with the broken line. Connect the surge absorber diode of the output load with the reverse polarity.



Caution

The diagram shown above is given as a reference for model selection.

When actually using the selected servo system, make wiring connections according to the connection diagram and instructions described in the user's manual.

Specifications of Servomotor

GYS Motor

100V series

Standard specifications

Motor type (-B indicates the brake-incorporated type.)	GYS500D5 - □□ 6 (-B)	GYS101D5 - □□ 6 (-B)	GYS201D5 - □□ 6 (-B)	GYS401D5 - □□ 6 (-B)
Rated output [kW]	0.05	0.1	0.2	0.375
Rated torque [N · m]	0.159	0.318	0.637	1.19
Rated speed [r/min]	3000			
Max. speed [r/min]	6000*1			
Max. torque [N · m]	0.478	0.955	1.91	3.58
Inertia [kg · m ²] () indicates brake-incorporated type.	0.0192 × 10 ⁻⁴ (0.0223 × 10 ⁻⁴)	0.0371 × 10 ⁻⁴ (0.0402 × 10 ⁻⁴)	0.135 × 10 ⁻⁴ (0.159 × 10 ⁻⁴)	0.246 × 10 ⁻⁴ (0.270 × 10 ⁻⁴)
Rated current [A]	0.85	1.5	2.7	4.8
Max. current [A]	2.55	4.5	8.1	14.4
Winding insulation class	Class B			
Degree of enclosure protection	Totally enclosed, self-cooled (IP 67, excluding the shaft sealing and connectors)			
Terminals (motor)	Cable 0.3m (with connector)			
Terminals (encoder)	Cable 0.3m (with connector)			
Overheat protection	Not provided (The servo amplifier detects temperature.)			
Mounting method	By securing motor flange IMB5 (L51), IMV1 (L52), IMV3 (L53)			
Encoder	18-bit serial encoder (absolute/incremental), 20-bit serial encoder (incremental)			
Vibration level*3	V5 or below			
Installation place, altitude and environment	For indoor use (free from direct sunlight), 1000m or below, locations without corrosive and flammable gases, oil mist and dust			
Ambient temperature, humidity	-10 to +40°C, within 90% RH max. (without condensation)			
Vibration resistance [m/s ²]	49			
Mass [kg] () indicates brake-incorporated type.	0.45 (0.6)	0.55 (0.7)	1.2 (1.7)	1.8 (2.3)
Compliance with standards	UL/cUL (UL1004), CE marking (EN60034-1, EN60034-5), RoHS directive			

*1 The maximum rotation speed is 5000r/min when using the motor in combination with Fuji's gear head.

*2 The load inertia ratio to the inertia of servo motor. If the moment of load inertia ratio value exceeds the list value, please contact us.

*3 The vibration value is the property of flange type IMV1(L52).

Brake specification (motor equipped with a brake)

Motor type	GYS500D5 - □□ 6-B	GYS101D5 - □□ 6-B	GYS201D5 - □□ 6-B	GYS401D5 - □□ 6-B
Static friction torque [N · m]	0.34		1.27	
Rated DC voltage [V]	DC24±10%			
Attraction time [ms]	35		40	
Release time [ms]	10		20	
Power consumption [W]	6.1 (at 20°C)		7.3 (at 20°C)	

Torque characteristics diagrams (at single-phase 100 [V] source voltage)

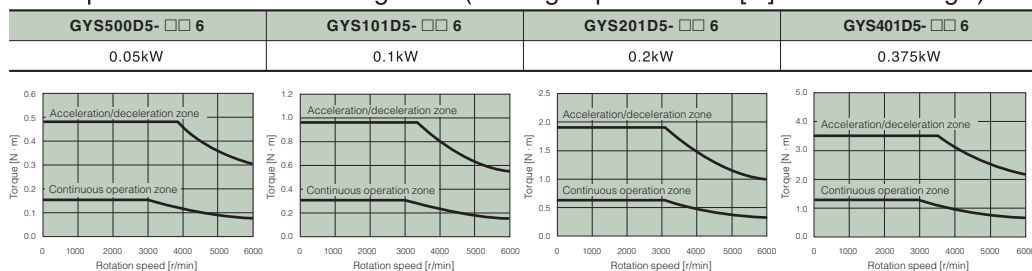

These characteristics indicate typical values of each servomotor combined with the corresponding RYT type servo amplifier.

The rated torque indicates the value obtained when the servo amplifier is installed to the following aluminum heat sink.

- Model GYS500D, 101D: 200 × 200 × 6 [mm]
- Model GYS201D, 401D: 250 × 250 × 6 [mm]

Specifications of Servomotor

GYS Motor

200V series

Standard specifications

Motor type (-B indicates the brake-incorporated type.)	GYS500D5 - □□ 2 (-B)	GYS101D5 - □□ 2 (-B)	GYS201D5 - □□ 2 (-B)	GYS401D5 - □□ 2 (-B)	GYS751D5 - □□ 2 (-B)
Rated output [kW]	0.05	0.1	0.2	0.4	0.75
Rated torque [N · m]	0.159	0.318	0.637	1.27	2.39
Rated speed [r/min]	3000				
Max. speed [r/min]	6000*1				
Max. torque [N · m]	0.478	0.955	1.91	3.82	7.17
Inertia [kg · m ²] () indicates brake-incorporated type.	0.0192 × 10 ⁻⁴ (0.0223 × 10 ⁻⁴)	0.0371 × 10 ⁻⁴ (0.0402 × 10 ⁻⁴)	0.135 × 10 ⁻⁴ (0.159 × 10 ⁻⁴)	0.246 × 10 ⁻⁴ (0.270 × 10 ⁻⁴)	0.853 × 10 ⁻⁴ (0.949 × 10 ⁻⁴)
Rated current [A]	0.85	0.85	1.5	2.7	4.8
Max. current [A]	2.55	2.55	4.5	8.1	14.4
Winding insulation class	Class B				
Degree of enclosure protection	Totally enclosed, self-cooled (IP 67, excluding the shaft sealing and connectors)				
Terminals (motor)	Cable 0.3m (with connector)				
Terminals (encoder)	Cable 0.3m (with connector)				
Overheat protection	Not provided (The servo amplifier detects temperature.)				
Mounting method	By securing motor flange IMB5 (L51), IMV1 (L52), IMV3 (L53)				
Encoder	18-bit serial encoder (absolute/incremental), 20-bit serial encoder (incremental)				
Vibration level*3	V5 or below				
Installation place, altitude and environment	For indoor use (free from direct sunlight), 1000m or below, locations without corrosive and flammable gases, oil mist and dust				
Ambient temperature, humidity	-10 to +40°C, within 90% RH max. (without condensation)				
Vibration resistance [m/s ²]	49				
Mass [kg] () indicates brake-incorporated type.	0.45 (0.62)	0.55 (0.72)	1.2 (1.7)	1.8 (2.3)	3.4 (4.2)
Compliance with standards	UL/cUL (UL1004), CE marking (EN60034-1, EN60034-5), RoHS directive				

*1 The maximum rotation speed is 5000r/min when using the motor in combination with Fujii's gear head.

*2 The load inertia ratio to the inertia of servo motor. If the moment of load inertia ratio value exceeds the list value, please contact us.

*3 The vibration value is the property of flange type IMV1(L52).

Brake specification (motor equipped with a brake)

Motor type	GYS500D5 - □□ 2-B	GYS101D5 - □□ 2-B	GYS201D5 - □□ 2-B	GYS401D5 - □□ 2-B	GYS751D5 - □□ 2-B
Static friction torque [N · m]	0.34		1.27		2.45
Rated DC voltage [V]	DC24±10%				
Attraction time [ms]	35		40		60
Release time [ms]	10		20		25
Power consumption [W]	6.1 (at 20°C)		7.3 (at 20°C)		8.5 (at 20°C)

Torque characteristics diagrams (at 3-phase 200 [V] or single-phase 230 [V] source voltage)

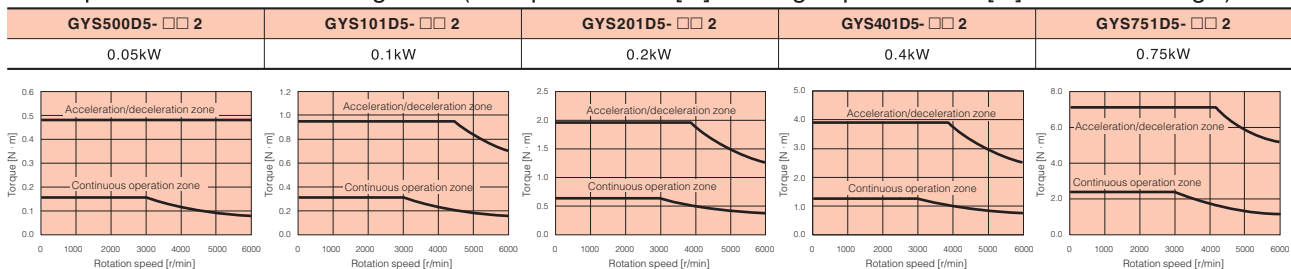

These characteristics indicate typical values of each servomotor combined with the corresponding RYT type servo amplifier.

The rated torque indicates the value obtained when the servo amplifier is installed to the following aluminum heat sink.

- Model GYS500D, 101D: 200 × 200 × 6 [mm]
- Model GYS201D, 401D: 250 × 250 × 6 [mm]
- Model GYS751D: 300 × 300 × 6 [mm]

Specifications of Servomotor

GYS Motor

200V series

Standard specifications

Motor type (-B) indicates the brake-incorporated type.	GYS102D5 - □□ 2 (-B)	GYS152D5 - □□ 2 (-B)	GYS202D5 - □□ 2 (-B)	GYS302D5 - □□ 2 (-B)	GYS402D5 - □□ 2 (-B)	GYS502D5 - □□ 2 (-B)
Rated output [kW]	1.0	1.5	2.0	3.0	4.0	5.0
Rated torque [N · m]	3.18	4.78	6.37	9.55	12.7	15.9
Rated speed [r/min]	3000					
Max. speed [r/min]	5000					
Max. torque [N · m]	9.55	14.3	19.1	28.7	38.2	47.8
Inertia [kg · m ²] () indicates brake-incorporated type.	1.73×10 ⁻⁴ (2.03×10 ⁻⁴)	2.37×10 ⁻⁴ (2.67×10 ⁻⁴)	3.01×10 ⁻⁴ (3.31×10 ⁻⁴)	8.32×10 ⁻⁴ (10.42×10 ⁻⁴)	10.8×10 ⁻⁴ (12.9×10 ⁻⁴)	12.8×10 ⁻⁴ (14.9×10 ⁻⁴)
Rated current [A]	7.1	9.6	12.6	18.0	24.0	30.0
Max. current [A]	21.3	28.8	37.8	54.0	72.0	90.0
Winding insulation class	Class F					
Degree of enclosure protection	Totally enclosed, self-cooled (IP 67, excluding the shaft sealing)*2					
Terminals (motor)	Cannon connector					
Terminals (encoder)	Cannon connector					
Overheat protection	Not provided (The servo amplifier detects temperature.)					
Mounting method	By securing motor flange IMB5 (L51), IMV1 (L52), IMV3 (L53)					
Encoder	18-bit serial encoder (absolute/incremental), 20-bit serial encoder (incremental)					
Vibration level*3	Up to rated rotation speed: V10 or below Over rated rotation speed and up to 5000r/min: V15 or below					
Installation place, altitude and environment	For indoor use (free from direct sunlight), 1000m or below, locations without corrosive and flammable gases, oil mist and dust					
Ambient temperature, humidity	-10 to +40°C, within 90% RH max.(without condensation)					
Vibration resistance [m/s ²]	24.5					
Mass [kg] () indicates brake-incorporated type.	4.4 (5.9)	5.2 (6.8)	6.3 (7.9)	11.0 (13.0)	13.5 (15.5)	16.0 (18.0)
Compliance with standards	UL/cUL (UL1004), CE marking (EN60034-1, EN60034-5), RoHS directive					

*1 The load inertia ratio to the inertia of servo motor. If the moment of load inertia ratio value exceeds the list value, please contact us.

*2 If the motor is used in the environment rated to IP67 protection degree, use the wiring connector suitable for the protection degree.

*3 The vibration value is the property of flange type IMV1(L52).

Brake specification (motor equipped with a brake)

Motor type	GYS102D5 - □□ 2-B	GYS152D5 - □□ 2-B	GYS202D5 - □□ 2-B	GYS302D5 - □□ 2-B	GYS402D5 - □□ 2-B	GYS502D5 - □□ 2-B
Static friction torque [N · m]	6.86			17		
Rated DC voltage [V]	DC24±10%					
Attraction time [ms]	100			120		
Release time [ms]	40			30		
Power consumption [W]	17.7 (at 20°C)			12 (at 20°C)		

Torque characteristics diagrams (at 3-phase 200 [V] or single-phase 230 [V] source voltage)

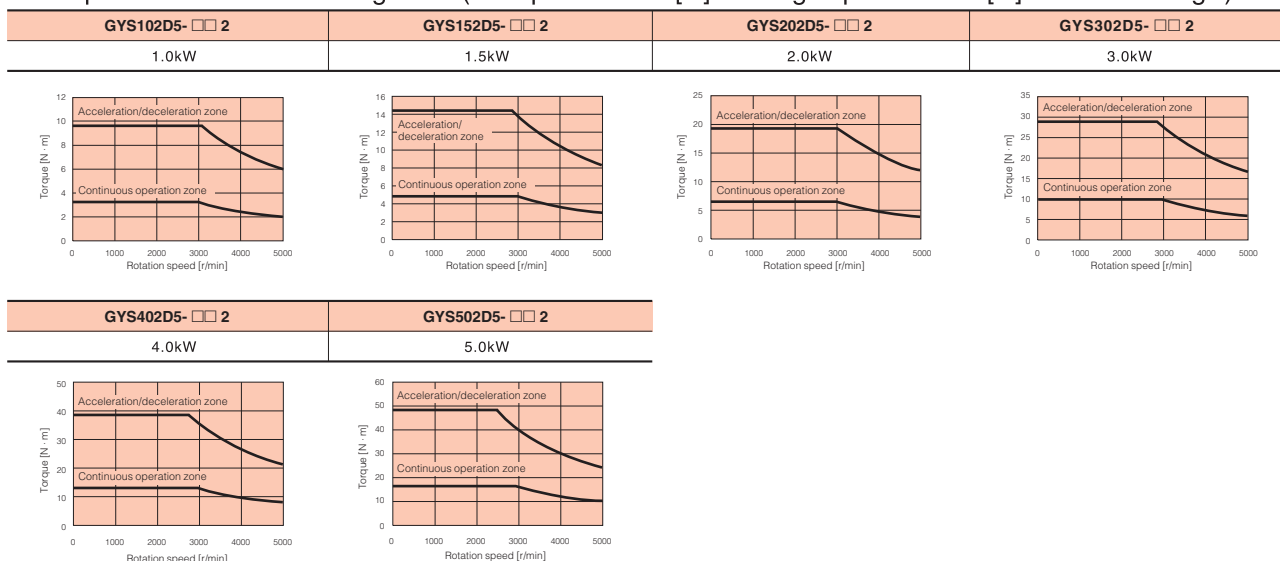

These characteristics indicate typical values of each servomotor combined with the corresponding RYT type servo amplifier.

The rated torque indicates the value obtained when the servo amplifier is installed to the following aluminum heat sink.

- Model GYS102D, 152D, 202D: 350 × 350 × 8 [mm]
- Model GYS302D, 402D, 502D: 400 × 400 × 12 [mm]

Specifications of Servomotor

GYC Motor

Standard specifications

Motor type (-B) indicates the brake-incorporated type.	GYC101D5 - □□ 2 (-B)	GYC201D5 - □□ 2 (-B)	GYC401D5 - □□ 2 (-B)	GYC751D5 - □□ 2 (-B)	GYC102D5 - □□ 2 (-B)	GYC152D5 - □□ 2 (-B)	GYC202D5 - □□ 2 (-B)
Rated output [kW]	0.1	0.2	0.4	0.75	1.0	1.5	2.0
Rated torque [N · m]	0.318	0.637	1.27	2.39	3.18	4.78	6.37
Rated speed [r/min]	3000						
Max. speed [r/min]	6000*1				5000		
Max. torque [N · m]	0.955	1.91	3.82	7.17	9.55	14.3	19.1
Inertia [kg · m ²] () indicates brake-incorporated type.	0.0577×10 ⁻⁴ (0.0727×10 ⁻⁴)	0.213×10 ⁻⁴ (0.288×10 ⁻⁴)	0.408×10 ⁻⁴ (0.483×10 ⁻⁴)	1.21×10 ⁻⁴ (1.66×10 ⁻⁴)	3.19×10 ⁻⁴ (5.29×10 ⁻⁴)	4.44×10 ⁻⁴ (6.54×10 ⁻⁴)	5.69×10 ⁻⁴ (7.79×10 ⁻⁴)
Rated current [A]	1.0	1.5	2.6	4.8	6.7	9.6	12.6
Max. current [A]	3.0	4.5	7.8	14.4	20.1	28.8	37.8
Winding insulation class	Class B				Class F		
Degree of enclosure protection	Totally enclosed, self-cooled (IP 67, excluding the shaft sealing and connectors)				Totally enclosed, self-cooled (IP 67, excluding the shaft sealing)*3		
Terminals (motor)	Cable 0.3m (with connector)				Cannon connector		
Terminals (encoder)	Cable 0.3m (with connector)				Cannon connector		
Overheat protection	Not provided (The servo amplifier detects temperature.)						
Mounting method	By securing motor flange IMB5 (L51), IMV1 (L52), IMV3 (L53)						
Encoder	18-bit serial encoder (absolute/incremental), 20-bit serial encoder (incremental)						
Vibration level*4	V5 or below				Up to rated rotation speed: V10 or below Over rated rotation speed and up to 5000r/min: V15 or below		
Installation place, altitude and environment	For indoor use (free from direct sunlight), 1000m or below, locations without corrosive and flammable gases, oil mist and dust						
Ambient temperature, humidity	-10 to +40°C, within 90% RH max.(without condensation)						
Vibration resistance [m/s ²]	49				24.5		
Mass [kg] () indicates brake-incorporated type.	0.75 (1.0)	1.3 (1.9)	1.9 (2.6)	3.5 (4.3)	5.7 (8.0)	7.0 (9.8)	8.2 (11.0)
Compliance with standards	UL/cUL (UL1004), CE marking (EN60034-1, EN60034-5), RoHS directive						

*1 The maximum rotation speed is 5000r/min when using the motor in combination with Fuji's gear head.

*2 The load inertia ratio to the inertia of servo motor. If the moment of load inertia ratio value exceeds the list value, please contact us.

*3 If the motor is used in the environment rated to IP67 protection degree, use the wiring connector suitable for the protection degree.

*4 The vibration value is the property of flange type IMV1(L52).

Brake specification (motor equipped with a brake)

Motor type	GYC101D5 - □□ 2-B	GYC201D5 - □□ 2-B	GYC401D5 - □□ 2-B	GYC751D5 - □□ 2-B	GYC102D5 - □□ 2-B	GYC152D5 - □□ 2-B	GYC202D5 - □□ 2-B
Static friction torque [N · m]	0.318	0.637	1.27	2.39	3.18	4.78	6.37
Rated DC voltage [V]	DC24±10%						
Attraction time [ms]	60	40	80	50	30	120	30
Release time [ms]	40						
Power consumption [W]	6.5 (at 20°C)	9.0 (at 20°C)	18.0 (at 20°C)	8.5 (at 20°C)	12 (at 20°C)	18 (at 20°C)	24 (at 20°C)

Torque characteristics diagrams (at 3-phase 200 [V] or single-phase 230 [V] source voltage)

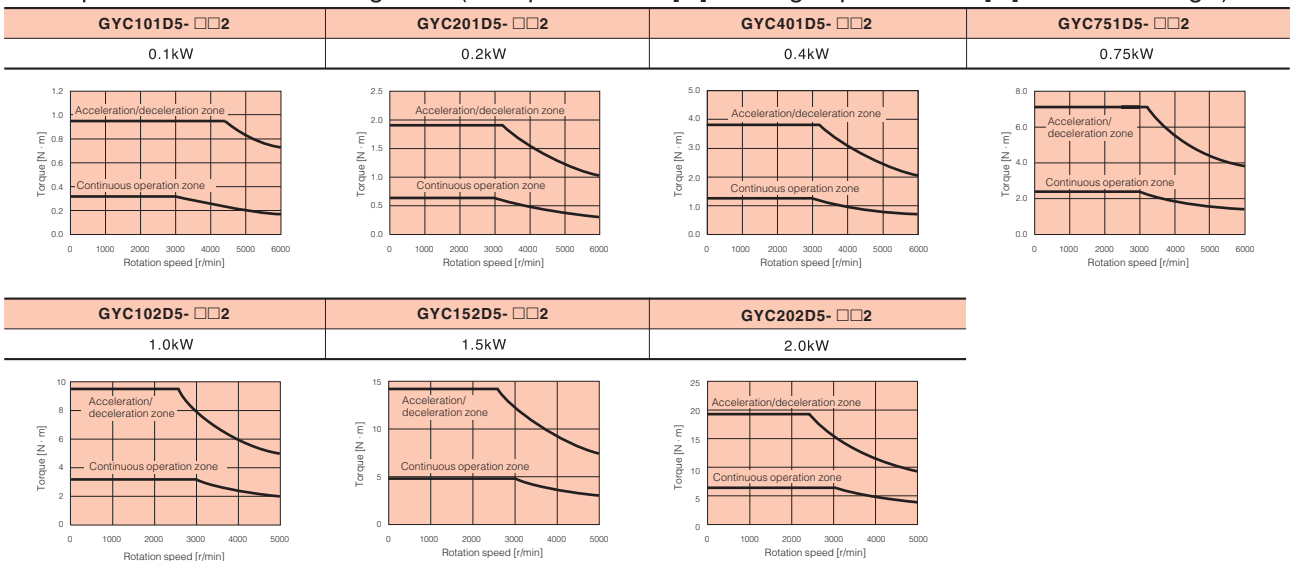

These characteristics indicate typical values of each servomotor combined with the corresponding RYT type servo amplifier.

The rated torque indicates the value obtained when the servo amplifier is installed to the following aluminum heat sink.

- Model GYC101D, 201D, 401D: 250 × 250 × 6 [mm]
- Model GYC751D: 300 × 300 × 6 [mm]
- Model GYC102D: 300 × 300 × 12 [mm]
- Model GYC152D, 202D: 400 × 400 × 12 [mm]

Specifications of Servomotor

GYG Motor [2000r/min]

Standard specifications

Motor type (-B indicates the brake-incorporated type.)	GYG501C5 - □□ 2 (-B)	GYG751C5 - □□ 2 (-B)	GYG102C5 - □□ 2 (-B)	GYG152C5 - □□ 2 (-B)	GYG202C5 - □□ 2 (-B)
Rated output [kW]	0.5	0.75	1.0	1.5	2.0
Rated torque [N · m]	2.39	3.58	4.77	7.16	9.55
Rated speed [r/min]	2000				
Max. speed [r/min]	3000				
Max. torque [N · m]	7.2	10.7	14.3	21.5	28.6
Inertia [kg · m ²] () indicates brake-incorporated type.	7.96×10 ⁻⁴ (10.0×10 ⁻⁴)	11.55×10 ⁻⁴ (13.6×10 ⁻⁴)	15.14×10 ⁻⁴ (17.2×10 ⁻⁴)	22.33×10 ⁻⁴ (24.4×10 ⁻⁴)	29.51×10 ⁻⁴ (31.6×10 ⁻⁴)
Rated current [A]	3.5	5.2	6.4	10	12.3
Max. current [A]	10.5	15.6	19.2	30.0	36.9
Winding insulation class	Class F				
Degree of enclosure protection	Totally enclosed, self-cooled (IP 67, excluding the shaft sealing)*2				
Terminals (motor)	Cannon connector				
Terminals (encoder)	Cannon connector				
Overheat protection	Not provided (The servo amplifier detects temperature.)				
Mounting method	By securing motor flange IMB5 (L51), IMV1 (L52), IMV3 (L53)				
Encoder	18-bit serial encoder (absolute/incremental), 20-bit serial encoder (incremental)				
Vibration level*3	V10 or below				
Installation place, altitude and environment	For indoor use (free from direct sunlight), 1000m or below, locations without corrosive and flammable gases, oil mist and dust				
Ambient temperature, humidity	-10 to +40°C, within 90% RH max.(without condensation)				
Vibration resistance [m/s ²]	24.5				
Mass [kg] () indicates brake-incorporated type.	5.3 (7.5)	6.4 (8.6)	7.5 (9.7)	9.8 (12.0)	12.0 (14.2)
Compliance with standards	UL/cUL (UL1004), CE marking (EN60034-1, EN60034-5), RoHS directive				

*1 The load inertia ratio to the inertia of servo motor. If the moment of load inertia ratio value exceeds the list value, please contact us.

*2 If the motor is used in the environment rated to IP67 protection degree, use the wiring connector suitable for the protection degree.

*3 The vibration value is the property of flange type IMV1(L52).

Brake specification (motor equipped with a brake)

Motor type	GYG501C5 - □□ 2-B	GYG751C5 - □□ 2-B	GYG102C5 - □□ 2-B	GYG152C5 - □□ 2-B	GYG202C5 - □□ 2-B
Static friction torque [N · m]	17				
Rated DC voltage [V]	DC24±10%				
Attraction time [ms]	120				
Release time [ms]	30				
Power consumption [W]	12 (at 20°C)				

Torque characteristics diagrams (at 3-phase 200[V])

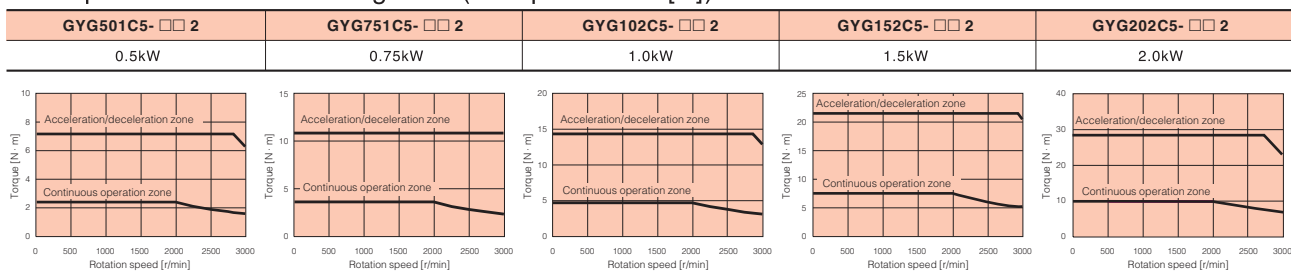

These characteristics indicate typical values of each servomotor combined with the corresponding RYT type servo amplifier.

The rated torque indicates the value obtained when the servo amplifier is installed to the following aluminum heat sink.

- Model GYG501C, 751C, 102C: 300 × 300 × 12 [mm]
- Model GYG152C, 202C: 400 × 400 × 12 [mm]

Specifications of Servomotor

GYG Motor [1500r/min]

Standard specifications

Motor type (-B) indicates the brake-incorporated type.	GYG501B5 - □□ 2 (-B)	GYG851B5 - □□ 2 (-B)	GYG132B5 - □□ 2 (-B)
Rated output [kW]	0.5	0.85	1.3
Rated torque [N · m]	3.18	5.41	8.28
Rated speed [r/min]	1500		
Max. speed [r/min]	3000		
Max. torque [N · m]	9.5	16.2	24.8
Inertia [kg · m ²] () indicates brake-incorporated type.	11.55 × 10 ⁻⁴ (13.6 × 10 ⁻⁴)	15.15 × 10 ⁻⁴ (17.3 × 10 ⁻⁴)	22.33 × 10 ⁻⁴ (24.5 × 10 ⁻⁴)
Rated current [A]	4.7	7.3	11.5
Max. current [A]	14.1	21.9	34.5
Winding insulation class	Class F		
Degree of enclosure protection	Totally enclosed, self-cooled (IP 67, excluding the shaft sealing)*2		
Terminals (motor)	Cannon connector		
Terminals (encoder)	Cannon connector		
Overheat protection	Not provided (The servo amplifier detects temperature.)		
Mounting method	By securing motor flange IMB5 (L51), IMV1 (L52), IMV3 (L53)		
Encoder	18-bit serial encoder (absolute/incremental), 20-bit serial encoder (incremental)		
Vibration level*3	V10 or below		
Installation place, altitude and environment	For indoor use (free from direct sunlight), 1000m or below, locations without corrosive and flammable gases, oil mist and dust		
Ambient temperature, humidity	-10 to +40°C, within 90% RH max.(without condensation)		
Vibration resistance [m/s ²]	24.5		
Mass [kg] () indicates brake-incorporated type.	6.4 (8.6)	7.5 (9.7)	9.8 (12.0)
Compliance with standards	UL/cUL (UL1004), CE marking (EN60034-1, EN60034-5), RoHS directive		

*1 The load inertia ratio to the inertia of servo motor. If the moment of load inertia ratio value exceeds the list value, please contact us.

*2 If the motor is used in the environment rated to IP67 protection degree, use the wiring connector suitable for the protection degree.

*3 The vibration value is the property of flange type IMV1(L52).

Brake specification (motor equipped with a brake)

Motor type	GYG501B5 - □□ 2-B	GYG851B5 - □□ 2-B	GYG132B5 - □□ 2-B
Static friction torque [N · m]	17		
Rated DC voltage [V]	DC24±10%		
Attraction time [ms]	120		
Release time [ms]	30		
Power consumption [W]	12 (at 20°C)		

Torque characteristics diagrams (at 3-phase 200[V])

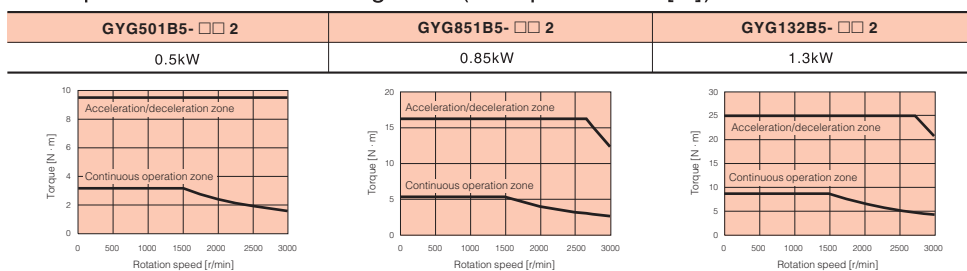

These characteristics indicate typical values of each servomotor combined with the corresponding RYT type servo amplifier.

The rated torque indicates the value obtained when the servo amplifier is installed to the following aluminum heat sink.

- Model GYG501B, 851B: 300 × 300 × 12 [mm]
- Model GYG132B: 400 × 400 × 12 [mm]

Specifications of Servomotor

GYB Motor

Standard specifications

Motor type (-B) indicates the brake-incorporated type.	GYB201D5 - □□ 2 (-B)	GYB401D5 - □□ 2 (-B)	GYB751D5 - □□ 2 (-B)
Rated output [kW]	0.2	0.4	0.75
Rated torque [N · m]	0.637	1.27	2.39
Rated speed [r/min]	3000		
Max. speed [r/min]	6000*1		
Max. torque [N · m]	1.91	3.82	7.17
Inertia [kg · m ²] () indicates brake-incorporated type.	0.24 × 10 ⁻⁴ (0.29 × 10 ⁻⁴)	0.42 × 10 ⁻⁴ (0.46 × 10 ⁻⁴)	1.43 × 10 ⁻⁴ (1.61 × 10 ⁻⁴)
Rated current [A]	1.5	2.7	5.2
Max. current [A]	4.5	8.1	15.6
Winding insulation class	Class B		
Degree of enclosure protection	Totally enclosed, self-cooled (IP 67, excluding the shaft-through)*2		
Terminals (motor)	0.3m cable		
Terminals (encoder)	0.3m cable		
Overheat protection	Not provided (The servo amplifier detects temperature.)		
Mounting method	By securing motor flange IMB5 (L51), IMV1 (L52), IMV3 (L53)		
Encoder	18-bit serial encoder (absolute/incremental), 20-bit serial encoder (incremental)		
Vibration level*3	V5 or below		
Installation place, altitude and environment	For indoor use (free from direct sunlight), 1000m or below, locations without corrosive and flammable gases, oil mist and dust		
Ambient temperature, humidity	-10 to +40°C, within 90% RH (without condensation)		
Vibration resistance [m/s ²]	49		
Mass [kg] () indicates brake-incorporated type.	1.0 (1.5)	1.5 (2.1)	3.0 (3.9)
Compliance with standards	UL/cUL (UL508c) (Some models are in the process of being certified), CE marking (low power directive EN61800-5-1), RoHS directive.		

*1 The max. speed of 5000r/min can be reached by using it with Fuji's gear head

*2 Protection degree IP67 is initial value

*3 The vibration value is the property of flange type IMV1(L52).

Brake specification (motor equipped with a brake)

Motor type	GYB201D5 - □□ 2-B	GYB401D5 - □□ 2-B	GYB751D5 - □□ 2-B
Static friction torque [N · m]	1.27		2.45
Rated DC voltage [V]	DC24±10%		
Attraction time [ms]	40		60
Release time [ms]	20		25
Power consumption [W]	7.2 (at 20°C)		8.5 (at 20°C)

Torque characteristics diagrams (at 3-phase 200 [V] or single-phase 230 [V] source voltage)

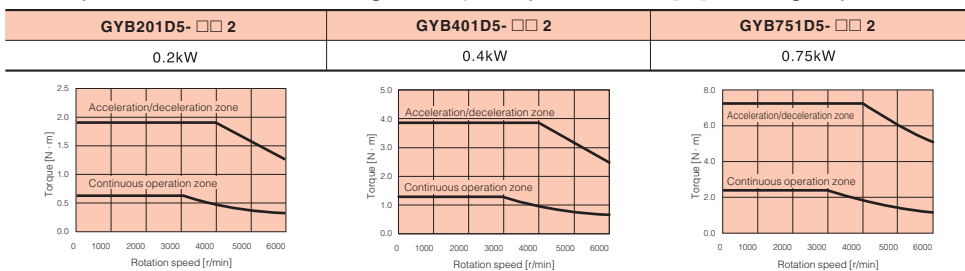

These characteristics indicate typical values of each servomotor combined with the corresponding servo amplifier RYH series.

The rated torque indicates the value obtained when the servo amplifier is installed to the following aluminum heat sink.

- Model GYB201D, 401D: 250 × 250 × 6 [mm]
- Model GYB751D: 300 × 300 × 6 [mm]

Option/Peripheral Equipment

<Example : 750W or less / 3000r/min>

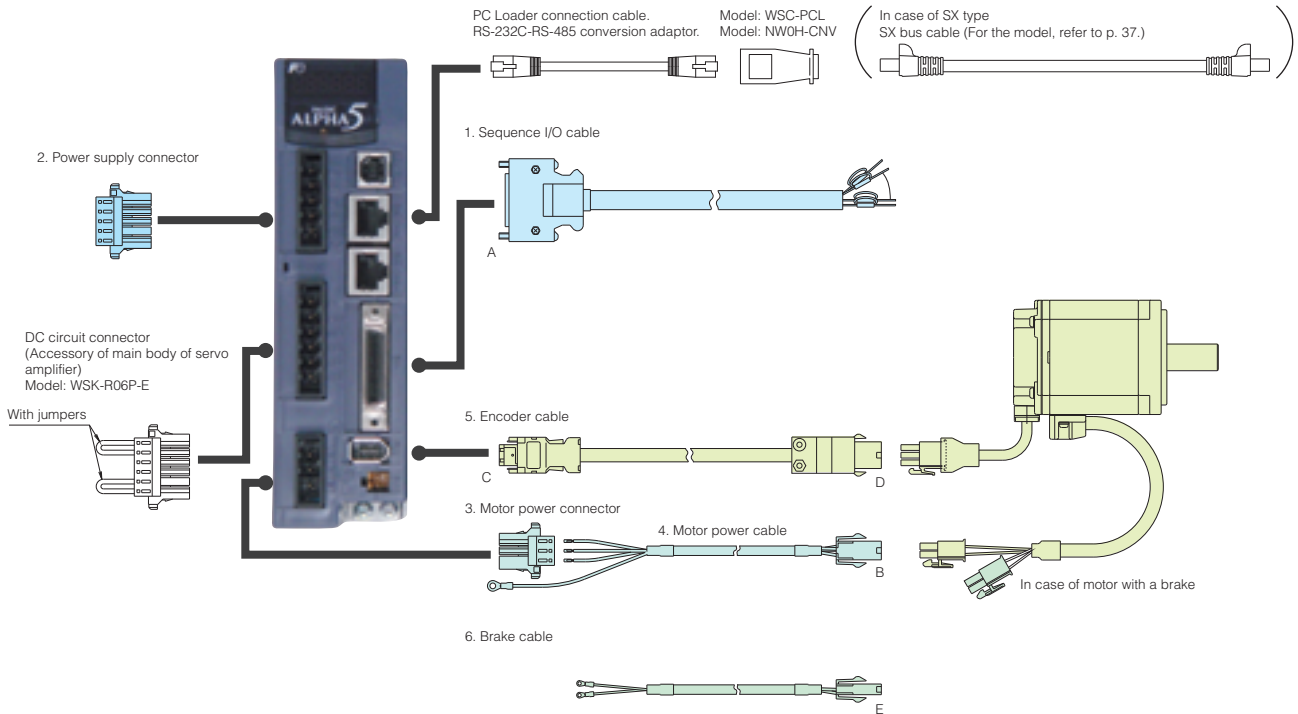

Option

Basic option

Motor series	Rated speed	Brake	Rated output	1. Sequence I/O cable (between host and amplifier)	2. Power supply connector	3. Motor power connector (on amplifier side)	4. Motor power cable (between amplifier and motor)	5. Encoder cable (between amplifier and motor)	6. Brake cable
GYS motor	3000r/min	Without a brake	0.05kW to 0.75kW	WSC-D36P03	WSK-S05P-E	WSK-M03P-E (Excluding 2kW)	WSC-M04P02-E	WSC-P06P02-E	—
		With a brake					WSC-M04P05-E	WSC-P06P05-E	WSC-M02P02-E
		Without a brake	1.0kW to 2.0kW				WSC-M04P10-E	WSC-P06P10-E	WSC-M02P05-E
		With a brake	3.0kW to 5.0kW				WSC-M04P20-E	WSC-P06P20-E	WSC-M02P10-E
GYC motor	3000r/min	Without a brake	0.05kW to 0.75kW		WSK-S05P-E	WSK-M03P-E (Excluding 2kW)	WSC-M04P02-E	WSC-P06P02-E	—
		With a brake					WSC-M04P05-E	WSC-P06P05-E	WSC-M02P02-E
		Without a brake	1.0kW to 2.0kW				WSC-M04P10-E	WSC-P06P10-E	WSC-M02P05-E
		With a brake	3.0kW to 5.0kW				WSC-M04P20-E	WSC-P06P20-E	WSC-M02P10-E
GYG motor	2000r/min	Without a brake	0.5kW to 1.0kW	WSK-S05P-E	WSK-M03P-E	*1	WSC-P06P05-C WSC-P06P10-C WSC-P06P20-C	—	
		With a brake				*2		*No cable is required.	
		Without a brake	1.5kW to 2.0kW			*1		—	
	With a brake	—	*2			*No cable is required.			
	1500r/min	Without a brake	0.5kW to 0.85kW			*1		—	
		With a brake	—			*2		*No cable is required.	
Without a brake		1.3kW	*1	—					
GYB motor	3000r/min	Without a brake	0.2kW, 0.4kW	WSK-S05P-E	WSK-M03P-E	WSC-M04P02-E	WSC-P06P02-E	WSC-M02P02-E	
		With a brake				WSC-M04P05-E	WSC-P06P05-E	WSC-M02P05-E	
		Without a brake	0.75kW			WSC-M04P10-E	WSC-P06P10-E	WSC-M02P10-E	
		With a brake	—			WSC-M04P20-E	WSC-P06P20-E	WSC-M02P20-E	

*1 The customer is requested to fabricate the cable using the connector for motor power (motor without brake): WSK-M04P-CA.

*2 The customer is requested to fabricate the cable using the connector for motor power (motor with brake): WSK-M06P-CA.

*3 The customer is requested to fabricate the cable using the connector for motor power (motor without brake): WSK-M04P-CB.

*4 The customer is requested to fabricate the cable using the connector for motor power (motor with brake): WSK-M06P-CB.

Option/Peripheral Equipment

Option

■ Connector kit * Use this connector if the customer fabricates the cable himself.

Motor series	Rated speed	Brake	Rated output	A Sequence I/O connector	B Motor power connector (on motor side)	Encoder connector		E Brake connector					
						C Amplifier side	D Motor side						
GYS motor (0.05~5.0kW) GYB motor (0.2~0.75kW)	3000r/min	Without a brake	0.05kW to 0.75kW	WSK-D36P	WSK-M04P-E	WSK-P06P-M	WSK-P09P-D	—					
		With a brake						WSK-M02P-E					
		Without a brake	1.0kW to 1.5kW					WSK-M04P-CA	WSK-P06P-C	—			
		With a brake						WSK-M06P-CA		—			
		Without a brake	2.0kW					WSK-M04P-CA		—			
		With a brake						WSK-M06P-CA		—			
Without a brake	3.0kW to 5.0kW	WSK-M04P-CB	—										
With a brake		WSK-M06P-CB	—										
GYC motor	3000r/min	Without a brake	0.05kW to 0.75kW		WSK-M04P-E		WSK-P06P-M	WSK-P09P-D	—				
		With a brake							WSK-M02P-E				
		Without a brake	1.0kW to 1.5kW						WSK-M04P-CB	WSK-P06P-C	—		
		With a brake							WSK-M06P-CB		—		
		Without a brake	2.0kW	WSK-M04P-CB		—							
		With a brake		WSK-M06P-CB		—							
Without a brake	0.5kW to 1.0kW	WSK-M04P-CA	WSK-P06P-C	—									
With a brake		WSK-M06P-CA		—									
GYG motor	2000r/min	Without a brake		0.5kW to 1.0kW	WSK-M04P-CA	WSK-P06P-M	WSK-P06P-C	—					
		With a brake							WSK-M06P-CA				
		Without a brake		1.5kW to 2.0kW					WSK-M04P-CA	WSK-P06P-C	—		
	With a brake	WSK-M06P-CA											
	1500r/min	Without a brake	0.5kW to 0.85kW	WSK-M04P-CA					WSK-P06P-M			WSK-P06P-C	—
		With a brake		WSK-M06P-CA									
Without a brake		1.3kW	WSK-M04P-CA	WSK-P06P-M	WSK-P06P-C	—							
With a brake	WSK-M06P-CA												

Peripheral equipment

Rated speed	Input power supply	Servo amplifier type	Output of applied motor [kW]	Power supply capacity [kVA]	Input current [A]	Power filter	AC reactor	DC reactor	Molded case circuit breaker	Ground fault interruptor	Electromagnetic contactor
3000r/min	Single-phase 100V	RYT500D5-□□6	0.05	0.1	1.5	RNFTC06-20	ACR2-0.4A	DCR2-0.4	EA32AC/3	EG32AC/3	SC-03
		RYT101D5-□□6	0.1	0.2	2.6	RNFTC10-20	ACR2-0.75A	DCR2-0.75	EA32AC/5	EG32AC/5	
		RYT201D5-□□6	0.2	0.4	4.8	RNFTC20-20	ACR2-1.5A	DCR2-1.5	EA32AC/10	EG32AC/10	
		RYT401D5-□□6	0.375	0.8	8.7	RNFTC20-20	ACR2-2.2A	DCR2-2.2	EA32AC/15	EG32AC/15	
		RYT500D5-□□2	0.05	0.1	0.7	RNFTC06-20	ACR2-0.4A	DCR2-0.2	EA32AC/3	EG32AC/3	
		RYT101D5-□□2	0.1	0.2	1.3			DCR2-0.4			
	RYT201D5-□□2	0.2	0.4	2.4	RNFTC10-20	ACR2-0.75A	DCR2-0.75	EA32AC/5	EG32AC/5		
	RYT401D5-□□2	0.4	0.8	4.7			DCR2-1.5				
	RYT751D5-□□2	0.75	1.5	8.6	RNFTC20-20	ACR2-2.2A	DCR2-2.2	EA32AC/15	EG32AC/15		
	3-phase 200V	Single-phase 200V	RYT500D5-□□2	0.05	0.1	0.4	RNFTC06-20	ACR2-0.4A	DCR2-0.2	EA33AC/3	EG33AC/3
			RYT101D5-□□2	0.1	0.2	0.7			DCR2-0.4		
			RYT201D5-□□2	0.2	0.4	1.4	RNFTC10-20	ACR2-0.75A	DCR2-0.75	EA33AC/5	EG33AC/5
			RYT401D5-□□2	0.4	0.8	2.7			DCR2-1.5		
			RYT751D5-□□2	0.75	1.5	5.0	RNFTC20-20	ACR2-1.5A	DCR2-1.5	EA33AC/10	EG33AC/10
			RYT102D5-□□2	1.0	2.0	6.6			DCR2-2.2		
		RYT152D5-□□2	1.5	2.9	9.8	RNFTC30-20	ACR2-2.2A	DCR2-2.2	EA33AC/20	EG33AC/20	
		RYT202D5-□□2	2.0	3.9	13.0	RNFTC30-20	ACR2-3.7A	DCR2-3.7	EA33AC/30	EG33AC/30	
		RYT302D5-□□2	3.0	5.9	19.5	RNFTC30-20	ACR2-5.5A	DCR2-5.5	EA53AC/40	EG53AC/40	
RYT402D5-□□2		4.0	7.8	26.0	RNFTC50-20	ACR2-7.5A	DCR2-7.5	EA53AC/50	EG53AC/50		
RYT502D5-□□2	5.0	9.8	32.5	RNFTC50-20	ACR2-11A	DCR2-11	EA53AC/50	EG53AC/50			
2000r/min	Single-phase 200V	RYT501C5-□□2	0.5	1.0	5.8	RNFTC10-20	ACR2-1.5A	DCR2-1.5	EA32AC/10	EG32AC/10	SC-03
		RYT751C5-□□2	0.75	1.5	8.6	RNFTC20-20	ACR2-2.2A	DCR2-2.2	EA32AC/15	EG32AC/15	SC-0
	3-phase 200V	RYT501C5-□□2	0.5	1.0	3.3	RNFTC06-20	ACR2-0.75A	DCR2-0.75	EA33AC/10	EG33AC/10	
		RYT751C5-□□2	0.75	1.5	5.0	RNFTC10-20	ACR2-1.5A	DCR2-1.5			
		RYT102C5-□□2	1.0	2.0	6.6	RNFTC20-20	ACR2-2.2A	DCR2-2.2	EA33AC/15	EG33AC/15	
		RYT152C5-□□2	1.5	2.9	9.8			DCR2-3.7	EA33AC/30	EG33AC/30	
RYT202C5-□□2	2.0	3.9	13.0	RNFTC20-20	ACR2-3.7A	DCR2-3.7	EA33AC/30	EG33AC/30			
1500r/min	Single-phase 200V	RYT501B5-□□2	0.5	1.0	5.8	RNFTC10-20	ACR2-1.5A	DCR2-1.5	EA32AC/10	EG32AC/10	SC-03
		RYT501B5-□□2	0.5	1.0	3.3	RNFTC06-20	ACR2-0.75A	DCR2-0.75	EA33AC/10	EG33AC/10	
	RYT851B5-□□2	0.85	1.7	5.6	RNFTC10-20	ACR2-1.5A	DCR2-1.5				
	RYT132B5-□□2	1.3	2.6	8.5	RNFTC20-20	ACR2-2.2A	DCR2-2.2	EA33AC/15	EG33AC/15		

External Dimensions

Servo amplifier

■ Frame 1

Power supply	Rated speed	Applicable motor output	Type
100V series	3000r/min	0.05kW	RYT500D5-□□ 6
		0.1kW	RYT101D5-□□ 6
200V series		0.05kW	RYT500D5-□□ 2
		0.1kW	RYT101D5-□□ 2
		0.2kW	RYT201D5-□□ 2

(Unit: mm)

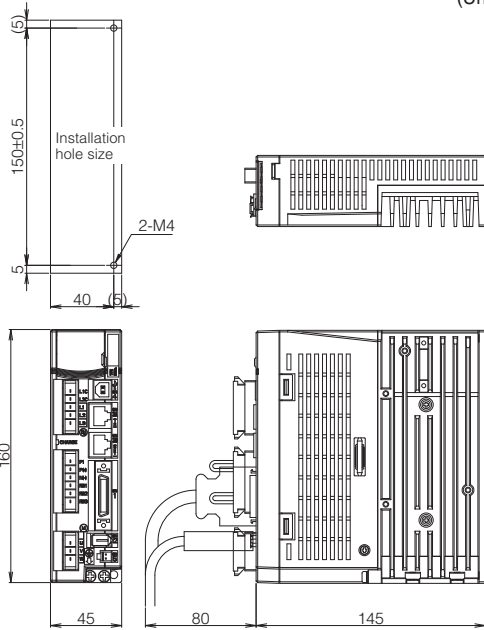

[Mass: 0.7kg]

■ Frame 2

Power supply	Rated speed	Applicable motor output	Type
100V series	3000r/min	0.2kW	RYT201D5-□□ 6
200V series		0.4kW	RYT401D5-□□ 2

(Unit: mm)

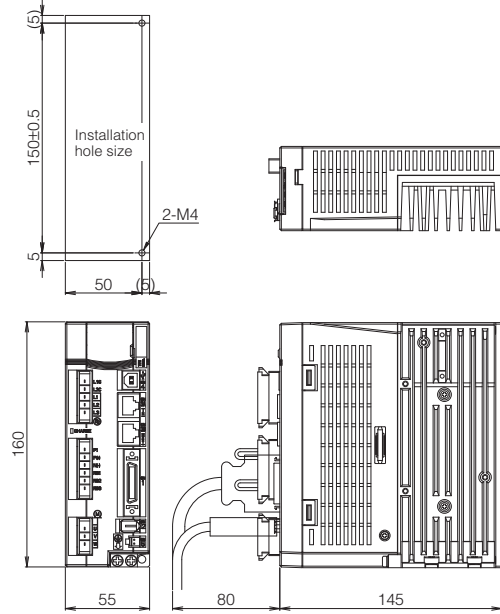

[Mass: 0.9kg]

■ Frame 3

Power supply	Rated speed	Applicable motor output	Type
100V series	3000r/min	0.375kW	RYT401D5-□□ 6
	1500r/min	0.5kW	RYT501B5-□□ 2
200V series	2000r/min	0.5kW	RYT501C5-□□ 2
		0.75kW	RYT751C5-□□ 2
	3000r/min	0.75kW	RYT751D5-□□ 2

(Unit: mm)

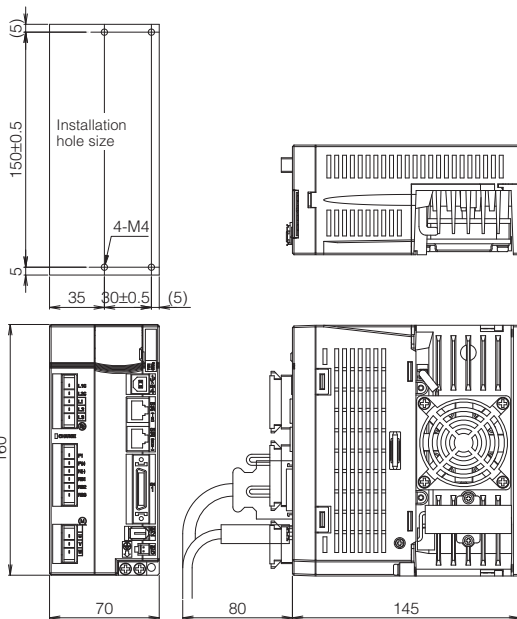

[Mass: 1.3kg]

■ Frame 4

Rated speed	Applicable motor output	Type
1500r/min	0.85kW	RYT851B5-□□ 2
2000r/min	1.0kW	RYT102C5-□□ 2
3000r/min	1.0kW	RYT102D5-□□ 2
	1.5kW	RYT152D5-□□ 2

(Unit: mm)

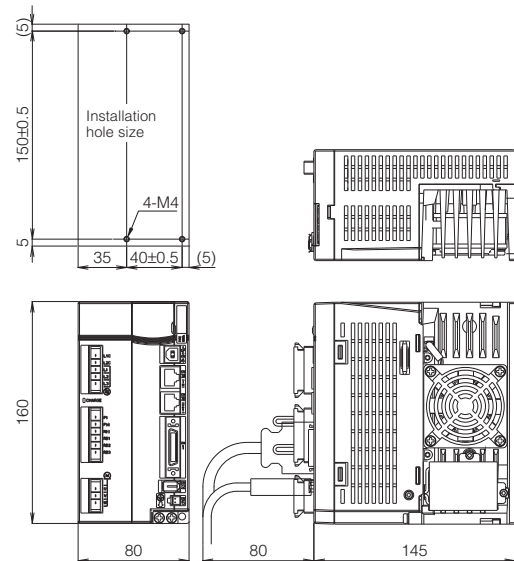

[Mass: 1.4kg]

External Dimensions

Servo amplifier

■ Frame 5

Rated speed	Applicable motor output	Type	Mass
1500r/min	1.3kW	RYT132B5- □□ 2	2.9kg
2000r/min	1.5kW	RYT152C5- □□ 2	
	2.0kW	RYT202C5- □□ 2	
3000r/min	2.0kW	RYT202D5- □□ 2	2.6kg
	3.0kW	RYT302D5- □□ 2	

(Unit: mm)

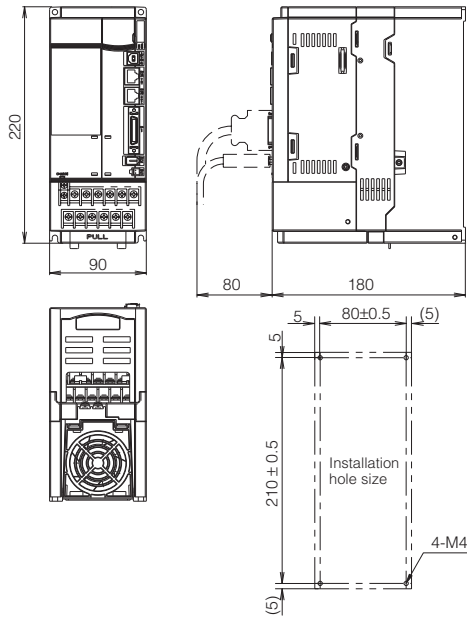

■ Frame 6

Rated speed	Applicable motor output	Type
3000r/min	4.0kW	RYT402D5- □□ 2
	5.0kW	RYT502D5- □□ 2

(Unit: mm)

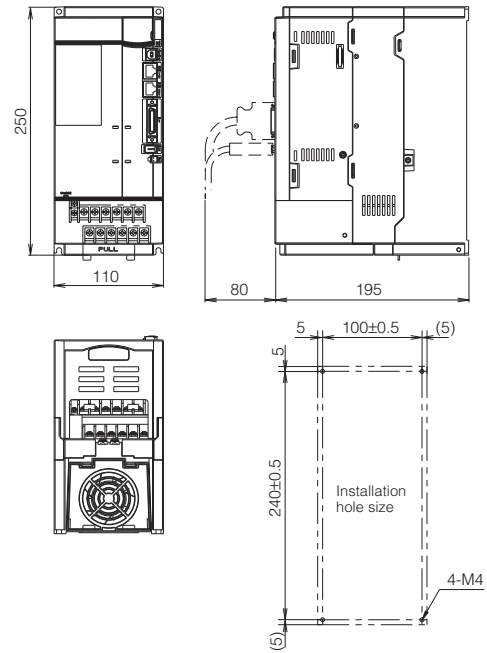

[Mass: 3.8kg]

External Dimensions

GYS Motor

Power supply	Rated speed	Rated output	Type	Shaft shape	Over length	Dimensions(flange)		Mass [kg]
						L	LL	
100V series	3000r/min	0.05kW	GYS500D5-□ B6	Fig. A	89	64	0.45	
		0.1kW	GYS101D5-□ B6	Fig. B	107	82	0.55	
200V series	3000r/min	0.05kW	GYS500D5-□ B2	Fig. A	89	64	0.45	
		0.1kW	GYS101D5-□ B2	Fig. B	107	82	0.55	

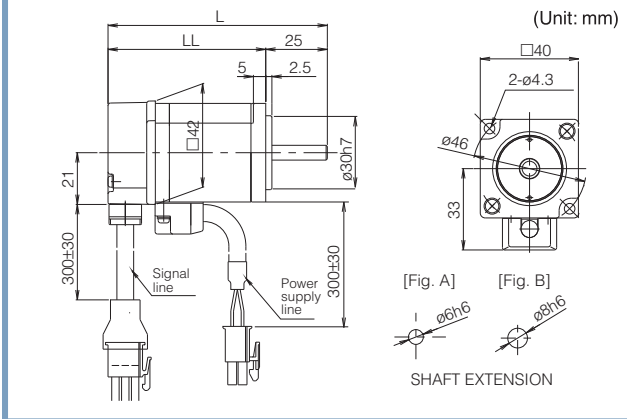

Power supply	Rated speed	Rated output	Type	Over length	Dimensions(flange)		Mass [kg]
					L	LL	
100V series	3000r/min	0.2kW	GYS201D5-□ B6	107.5	77.5	1.2	
		0.375kW	GYS401D5-□ B6	135.5	105.5	1.8	
200V series	3000r/min	0.2kW	GYS201D5-□ B2	107.5	77.5	1.2	
		0.4kW	GYS401D5-□ B2	135.5	105.5	1.8	

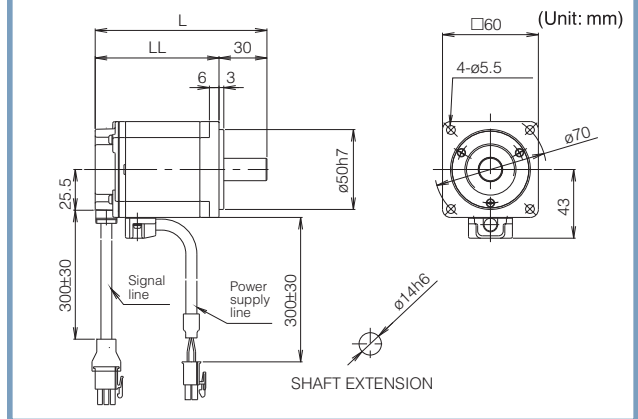

Rated speed	Rated output	Type
3000r/min	0.75kW	GYS751D5-□ B2

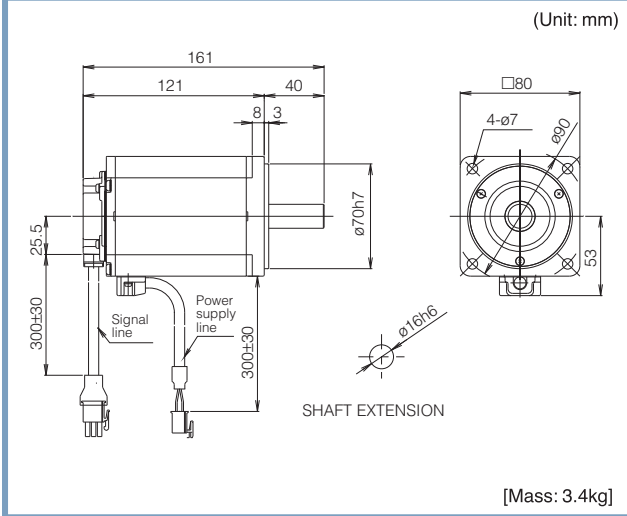

Rated speed	Rated output	Type	Over length	Dimensions(flange)		Terminal	Mass [kg]
				L	LL		
3000r/min	1kW	GYS102D5-□ B2	198	153	77	4.4	
	1.5kW	GYS152D5-□ B2	220.5	175.5	99.5	5.2	
	2kW	GYS202D5-□ B2	243	198	122	6.3	

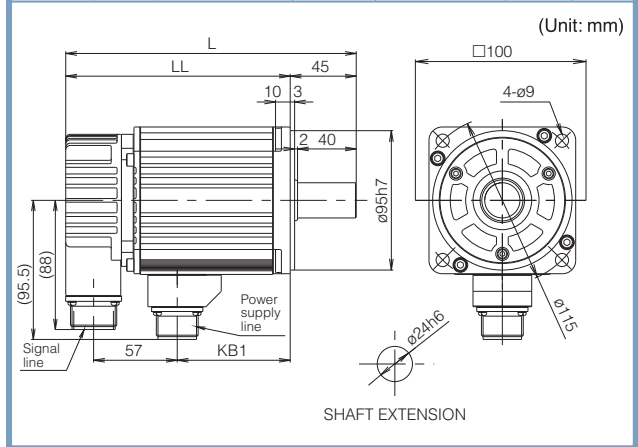

Rated speed	Rated output	Type	Over length	Dimensions(flange)		Terminal	Mass [kg]
				L	LL		
3000r/min	3kW	GYS302D5-□ B2	262.5	199.5	125.5	11	
	4kW	GYS402D5-□ B2	292.5	229.5	155.5	13.5	
	5kW	GYS502D5-□ B2	322.5	259.5	185.5	16	

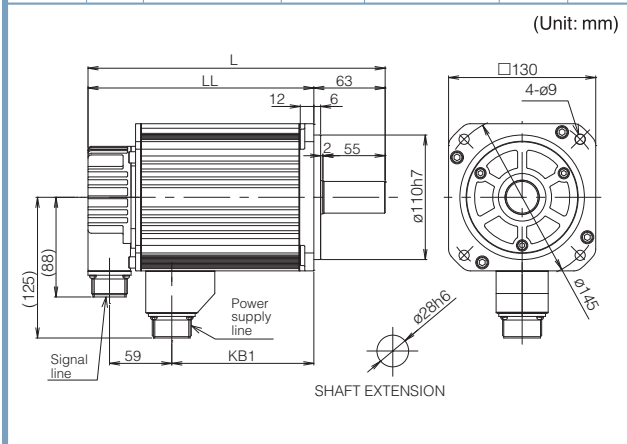

* See page 33 for the shaft extension specifications of the motor with a key.

External Dimensions

GYC Motor

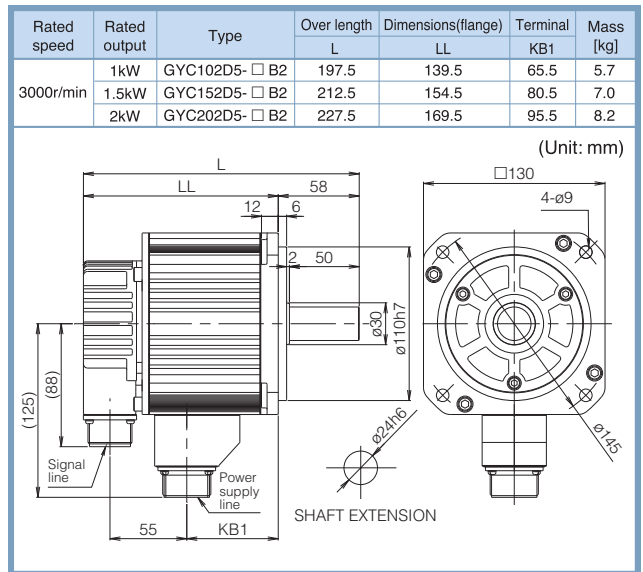
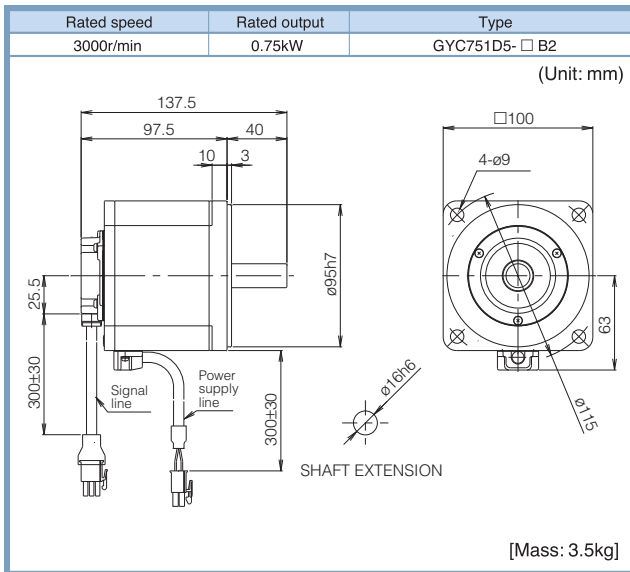
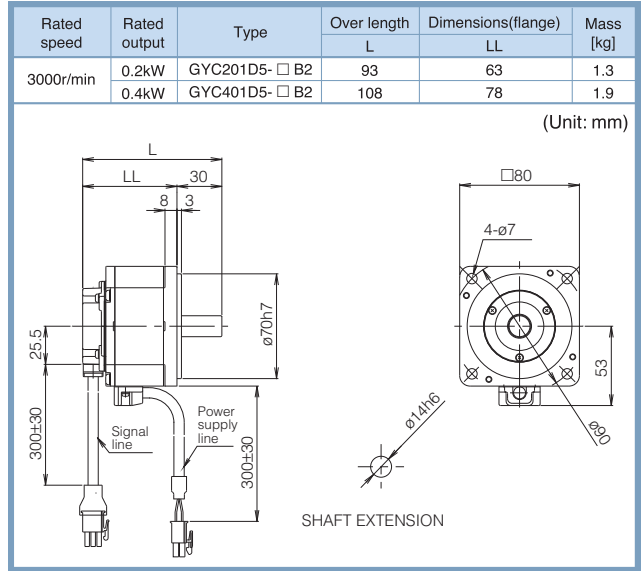
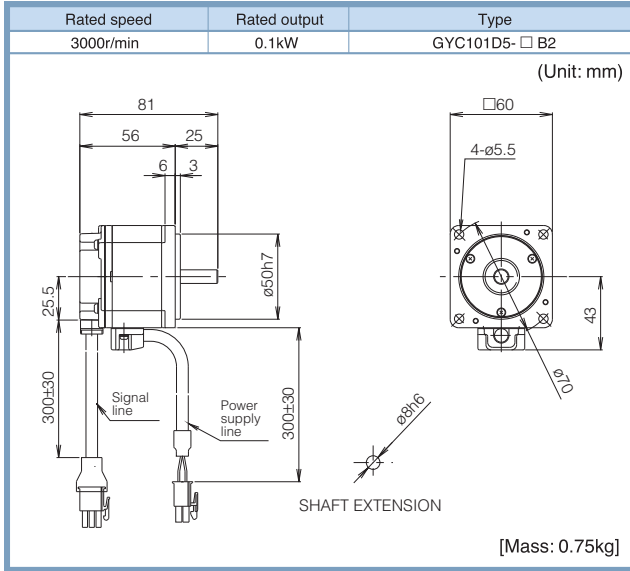

* See page 33 for the shaft extension specifications of the motor with a key.

External Dimensions

GYG Motor [2000r/min]

Rated speed	Rated output	Type	Over length		Dimensions(flange)		Terminal KB1	Mass [kg]
			L	LL	LL	LL		
2000r/min	0.5kW	GYG501C5-□ B2	175	120	47.5	5.3		
	0.75kW	GYG751C5-□ B2	187.5	132.5	60	6.4		

(Unit: mm)

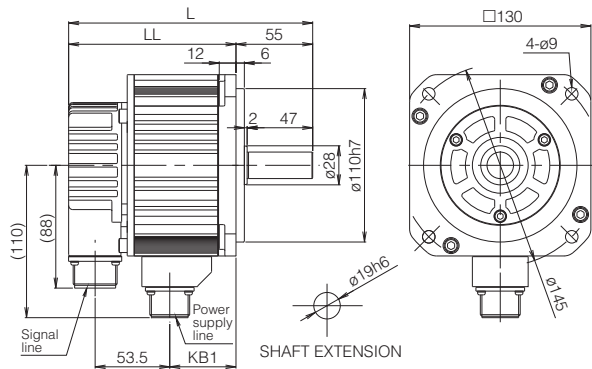

Rated speed	Rated output	Type	Over length		Dimensions(flange)		Terminal KB1	Mass [kg]
			L	LL	LL	LL		
2000r/min	1kW	GYG102C5-□ B2	200	145	72.5	7.5		
	1.5kW	GYG152C5-□ B2	225	170	97.5	9.8		
	2kW	GYG202C5-□ B2	250	195	122.5	12		

(Unit: mm)

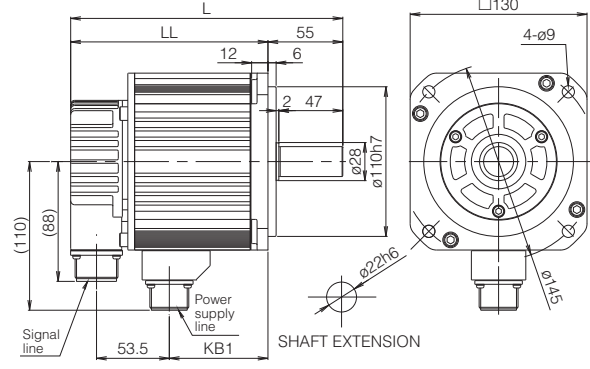

* See page 33 for the shaft extension specifications of the motor with a key.

GYG Motor [2000r/min] (With a brake)

Rated speed	Rated output	Type	Over length		Dimensions(flange)		Terminal KB1	Mass [kg]
			L	LL	LL	LL		
2000r/min	0.5kW	GYG501C5-□ B2-B	217.5	162.5	52	7.5		
	0.75kW	GYG751C5-□ B2-B	230	175	64.5	8.6		

(Unit: mm)

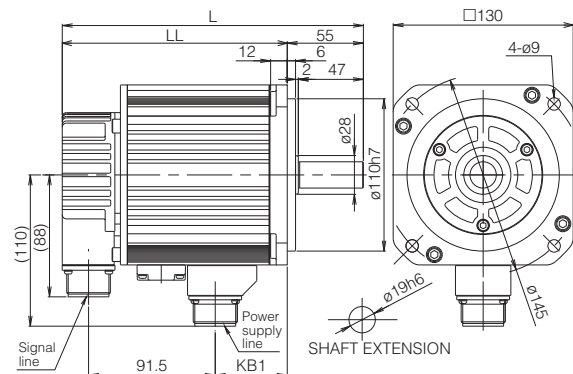

Rated speed	Rated output	Type	Over length		Dimensions(flange)		Terminal KB1	Mass [kg]
			L	LL	LL	LL		
2000r/min	1kW	GYG102C5-□ B2-B	242.5	187.5	77	9.7		
	1.5kW	GYG152C5-□ B2-B	267.5	212.5	102	12		
	2kW	GYG202C5-□ B2-B	292.5	237.5	127	14.2		

(Unit: mm)

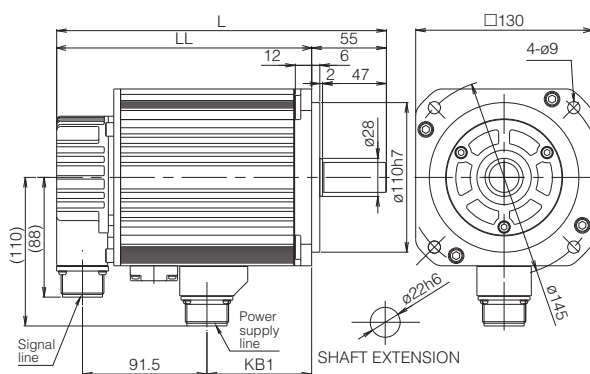

* See page 33 for the shaft extension specifications of the motor with a key.

External Dimensions

GYG Motor [1500r/min]

Rated speed	Rated output	Type	Over length	Dimensions(flange)		Terminal	Mass [kg]
			L	LL	KB1		
1500r/min	0.5kW	GYG501B5-□ B2	190.5	132.5	60	6.4	
	0.85kW	GYG851B5-□ B2	203	145	72.5	7.5	

(Unit: mm)

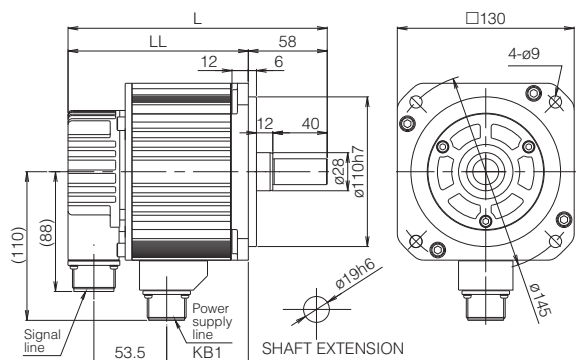

Rated speed	Rated output	Type
1500r/min	1.3kW	GYG132B5-□ B2

(Unit: mm)

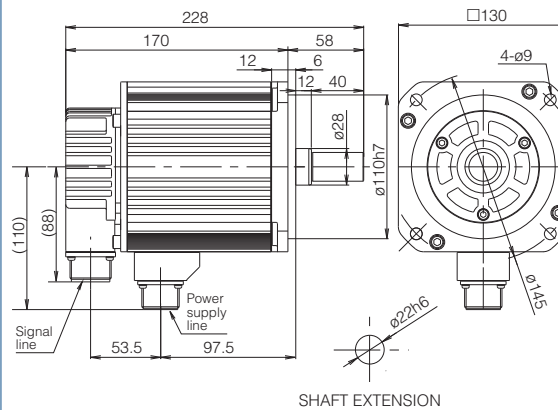

[Mass: 9.8kg]

* See page 33 for the shaft extension specifications of the motor with a key.

GYG Motor [1500r/min] (With a brake)

Rated speed	Rated output	Type	Over length	Dimensions(flange)		Terminal	Mass [kg]
			L	LL	KB1		
1500r/min	0.5kW	GYG501B5-□ B2-B	233	175	64.5	8.6	
	0.85kW	GYG851B5-□ B2-B	245.5	187.5	77	9.7	

(Unit: mm)

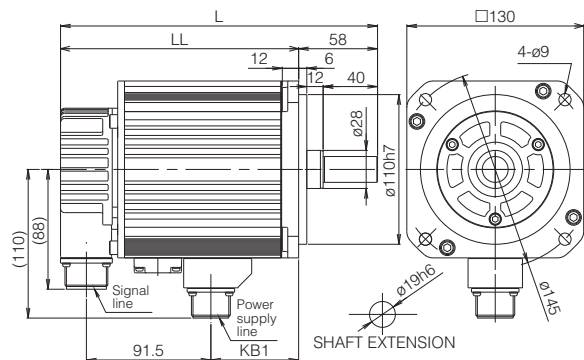

Rated speed	Rated output	Type
1500r/min	1.3kW	GYG132B5-□ B2-B

(Unit: mm)

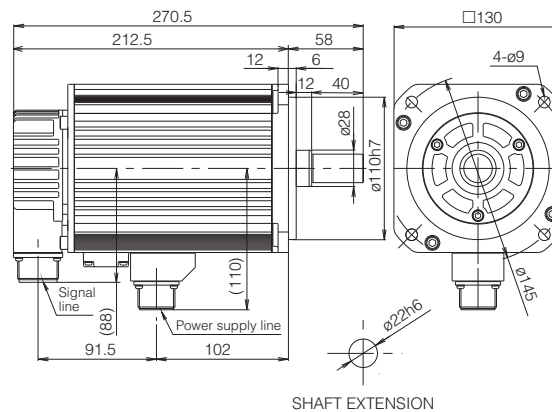

[Mass: 12kg]

* See page 33 for the shaft extension specifications of the motor with a key.

External Dimensions

GYB Motor

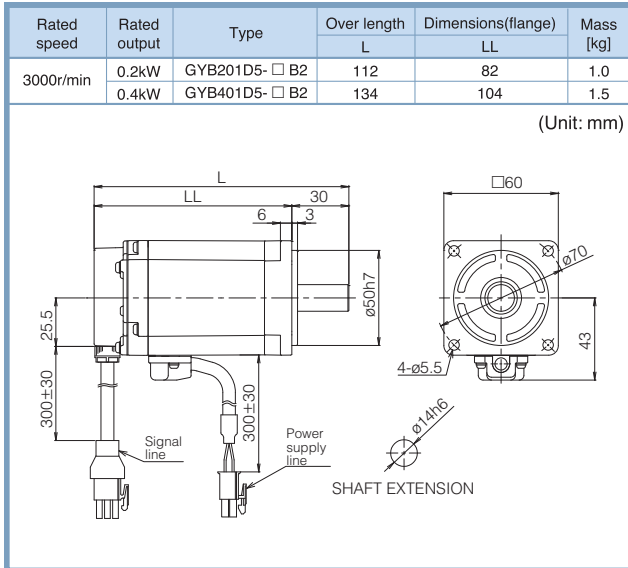

* See page 33 for the shaft extension specifications of the motor with a key.

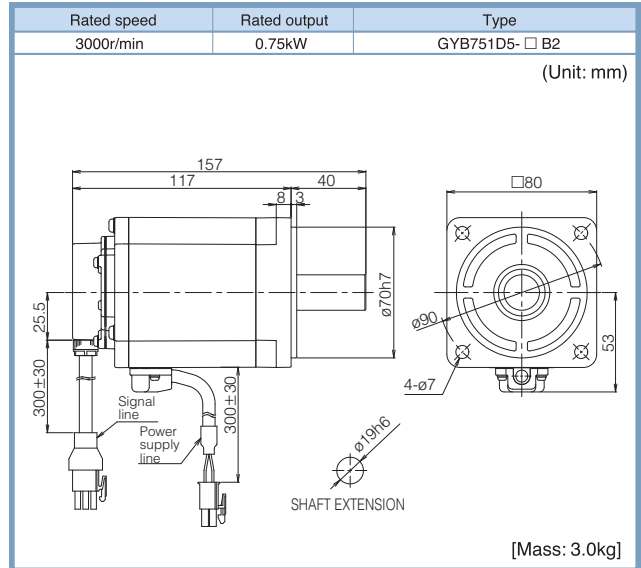

GYB Motor (With a brake)

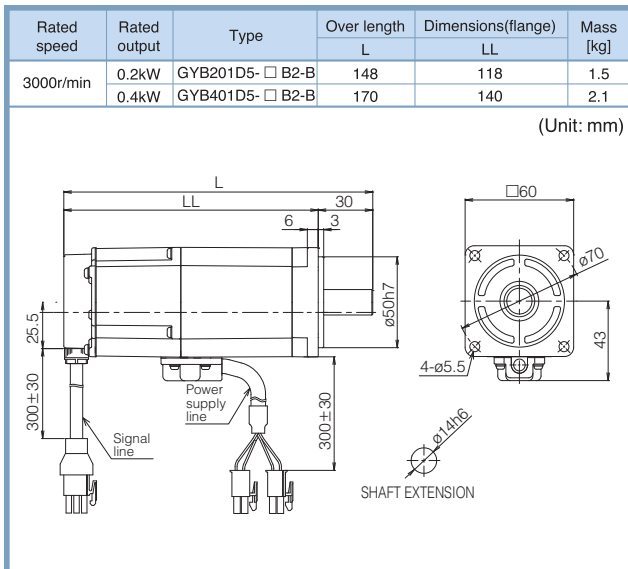

* See page 33 for the shaft extension specifications of the motor with a key.

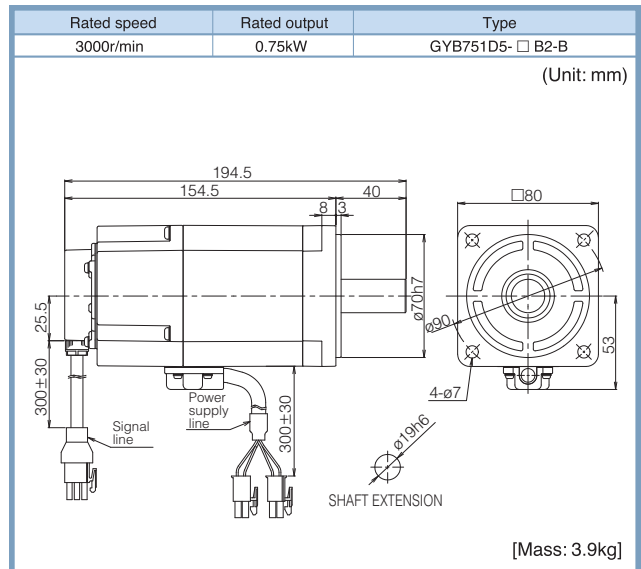

External Dimensions

Shaft Extension Specifications (with a key, tapped)

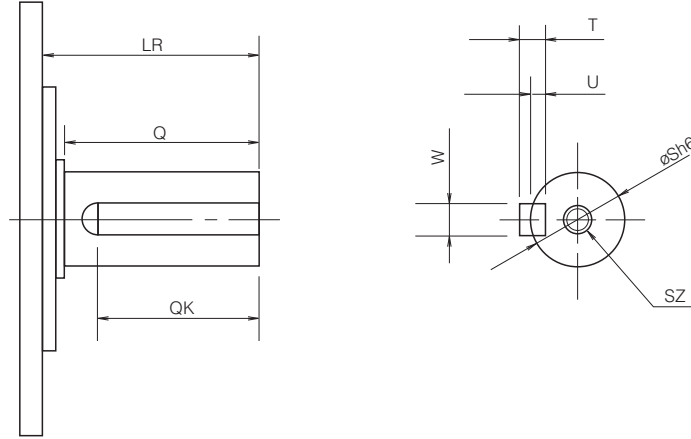

Motor type	LR	Q	QK	S	T	U	W	SZ
GYS Motor								
GYS500D5-□A□-□ *1	25	-	14	6	2	1.2	2	-
GYS101D5-□A□-□ *1				8	3	1.8	3	-
GYS201D5-□C□-□	30		20	14	5	3	5	M5 depth:8
GYS401D5-□C□-□								
GYS751D5-□C2-□	40		30	16				
GYS102D5-□C2-□	45	40	32	24	7	4	8	M8 depth:16
GYS152D5-□C2-□								
GYS202D5-□C2-□								
GYS302D5-□C2-□	63	55	45	28				
GYS402D5-□C2-□								
GYS502D5-□C2-□								
GYC Motor								
GYC101D5-□A2-□ *1	25	-	14	8	3	1.8	3	-
GYC201D5-□C2-□	30		16	14	5	3	5	M5 depth:8
GYC401D5-□C2-□								
GYC751D5-□C2-□	40		22	16				
GYC102D5-□C2-□	58	50	40	24	7	4	8	M8 depth:16
GYC152D5-□C2-□								
GYC202D5-□C2-□								
GYG Motor 2000r/min								
GYG501C5-□C2-□	55	47	35	19	6	3.5	6	M6 depth:12
GYG751C5-□C2-□				22	7	4	8	M8 depth:16
GYG102C5-□C2-□								
GYG152C5-□C2-□								
GYG202C5-□C2-□								
GYG Motor 1500r/min								
GYG501B5-□C2-□	58	40	30	19	6	3.5	6	M6 depth:12
GYG851B5-□C2-□								
GYG132B5-□C2-□				22	7	4	8	M8 depth:16
GYB Motor								
GYB201D5-□C2-□	30	-	14	14	5	3	5	M5 depth:8
GYB401D5-□C2-□								
GYB751D5-□C2-□	40	-	22	19	6	3.5	6	M6 depth:10

*1 The shaft extension of the GYS and GYC motors of 0.1kW or less is not tapped.

Model List

Servo amplifier

Specifications						
Model	Control mode	Command interface	Input power supply	Applicable motor	Applicable motor output	Type
VV type	Position, speed and torque control (With built-in linear positioning function)	General-purpose interface (pulse or analog voltage) (Di/Do) (Modbus-RTU)	Single-phase or 3-phase 200 to 240V	GYS, GYC, GYB motor 3000r/min	0.05kW	RYT500D5-VV2
					0.1kW	RYT101D5-VV2
					0.2kW	RYT201D5-VV2
					0.4kW	RYT401D5-VV2
					0.75kW	RYT751D5-VV2
					1.0kW	RYT102D5-VV2
					1.5kW	RYT152D5-VV2
					2.0kW	RYT202D5-VV2
					3.0kW	RYT302D5-VV2
					4.0kW	RYT402D5-VV2
				5.0kW	RYT502D5-VV2	
				0.05kW	RYT500D5-VV6	
				0.1kW	RYT101D5-VV6	
				0.2kW	RYT201D5-VV6	
				0.375kW	RYT401D5-VV6	
				0.5kW	RYT501C5-VV2	
				0.75kW	RYT751C5-VV2	
				1.0kW	RYT102C5-VV2	
				1.5kW	RYT152C5-VV2	
				2.0kW	RYT202C5-VV2	
				0.5kW	RYT501B5-VV2	
	0.85kW	RYT851B5-VV2				
	1.3kW	RYT132B5-VV2				
VS type	Position, speed and torque control	High speed serial bus (SX bus)	Single-phase or 3-phase 200 to 240V	GYS, GYC, GYB motor 3000r/min	0.05kW	RYT500D5-VS2
					0.1kW	RYT101D5-VS2
					0.2kW	RYT201D5-VS2
					0.4kW	RYT401D5-VS2
					0.75kW	RYT751D5-VS2
					1.0kW	RYT102D5-VS2
					1.5kW	RYT152D5-VS2
					2.0kW	RYT202D5-VS2
					3.0kW	RYT302D5-VS2
					4.0kW	RYT402D5-VS2
				5.0kW	RYT502D5-VS2	
				0.05kW	RYT500D5-VS6	
				0.1kW	RYT101D5-VS6	
				0.2kW	RYT201D5-VS6	
				0.375kW	RYT401D5-VS6	
				0.5kW	RYT501C5-VS2	
				0.75kW	RYT751C5-VS2	
				1.0kW	RYT102C5-VS2	
				1.5kW	RYT152C5-VS2	
				2.0kW	RYT202C5-VS2	
				0.5kW	RYT501B5-VS2	
	0.85kW	RYT851B5-VS2				
	1.3kW	RYT132B5-VS2				
LS type	Position control (With built-in linear positioning function)	High speed serial bus (SX bus)	Single-phase or 3-phase 200 to 240V	GYS, GYC, GYB motor 3000r/min	0.05kW	RYT500D5-LS2
					0.1kW	RYT101D5-LS2
					0.2kW	RYT201D5-LS2
					0.4kW	RYT401D5-LS2
					0.75kW	RYT751D5-LS2
					1.0kW	RYT102D5-LS2
					1.5kW	RYT152D5-LS2
					2.0kW	RYT202D5-LS2
					3.0kW	RYT302D5-LS2
					4.0kW	RYT402D5-LS2
				5.0kW	RYT502D5-LS2	
				0.05kW	RYT500D5-LS6	
				0.1kW	RYT101D5-LS6	
				0.2kW	RYT201D5-LS6	
				0.375kW	RYT401D5-LS6	
				0.5kW	RYT501C5-LS2	
				0.75kW	RYT751C5-LS2	
				1.0kW	RYT102C5-LS2	
				1.5kW	RYT152C5-LS2	
				2.0kW	RYT202C5-LS2	
				0.5kW	RYT501B5-LS2	
	0.85kW	RYT851B5-LS2				
	1.3kW	RYT132B5-LS2				

Model List

Servomotor

Specifications								
Model	Voltage	Rated speed	Oil seal/shaft	Encoder	Brake	Rated output	Type	
GYS motor (ultra low inertia)	200V	3000r/min	Without an oil seal and a key (*1)	18-bit ABS	Without a brake	0.05kW	GYS500D5-HB2	
						0.1kW	GYS101D5-HB2	
						0.2kW	GYS201D5-HB2	
						0.4kW	GYS401D5-HB2	
						0.75kW	GYS751D5-HB2	
						1.0kW	GYS102D5-HB2	
						1.5kW	GYS152D5-HB2	
						2.0kW	GYS202D5-HB2	
						3.0kW	GYS302D5-HB2	
						4.0kW	GYS402D5-HB2	
						5.0kW	GYS502D5-HB2	
						With a brake	0.05kW	GYS500D5-HB2-B
					0.1kW		GYS101D5-HB2-B	
					0.2kW		GYS201D5-HB2-B	
					0.4kW		GYS401D5-HB2-B	
					0.75kW		GYS751D5-HB2-B	
					1.0kW		GYS102D5-HB2-B	
					1.5kW		GYS152D5-HB2-B	
					2.0kW		GYS202D5-HB2-B	
					3.0kW		GYS302D5-HB2-B	
					4.0kW		GYS402D5-HB2-B	
					5.0kW		GYS502D5-HB2-B	
					20-bit INC		Without a brake	0.05kW
						0.1kW		GYS101D5-RB2
	0.2kW	GYS201D5-RB2						
	0.4kW	GYS401D5-RB2						
	0.75kW	GYS751D5-RB2						
	1.0kW	GYS102D5-RB2						
	1.5kW	GYS152D5-RB2						
	2.0kW	GYS202D5-RB2						
	3.0kW	GYS302D5-RB2						
	4.0kW	GYS402D5-RB2						
	5.0kW	GYS502D5-RB2						
	With a brake	0.05kW	GYS500D5-RB2-B					
		0.1kW	GYS101D5-RB2-B					
		0.2kW	GYS201D5-RB2-B					
		0.4kW	GYS401D5-RB2-B					
		0.75kW	GYS751D5-RB2-B					
		1.0kW	GYS102D5-RB2-B					
		1.5kW	GYS152D5-RB2-B					
		2.0kW	GYS202D5-RB2-B					
		3.0kW	GYS302D5-RB2-B					
		4.0kW	GYS402D5-RB2-B					
		5.0kW	GYS502D5-RB2-B					
		100V	3000r/min	Without an oil seal and a key (*1)		18-bit ABS	Without a brake	0.05kW
	0.1kW							GYS101D5-HB6
	0.2kW				GYS201D5-HB6			
	0.375kW				GYS401D5-HB6			
With a brake	0.05kW				GYS500D5-HB6-B			
	0.1kW				GYS101D5-HB6-B			
	0.2kW				GYS201D5-HB6-B			
	0.375kW				GYS401D5-HB6-B			
	20-bit INC				Without a brake		0.05kW	GYS500D5-RB6
							0.1kW	GYS101D5-RB6
0.2kW							GYS201D5-RB6	
0.375kW							GYS401D5-RB6	
With a brake			0.05kW			GYS500D5-RB6-B		
			0.1kW			GYS101D5-RB6-B		
			0.2kW		GYS201D5-RB6-B			
			0.375kW		GYS401D5-RB6-B			

*1: The motor with a shaft extension with a key and tapped is available as a semi-standard item. (See page 33 for shaft extension specifications.)
The other specifications are handled as a made-to-order item.

Model List

Servomotor

Specifications							Type					
Model	Voltage	Rated speed	Oil seal/shaft	Encoder	Brake	Rated output	Type					
GYC motor (low inertia)	200V	3000r/min	Without an oil seal and a key (*1)	18-bit ABS	Without a brake	0.1kW	GYC101D5-HB2					
						0.2kW	GYC201D5-HB2					
						0.4kW	GYC401D5-HB2					
						0.75kW	GYC751D5-HB2					
						1.0kW	GYC102D5-HB2					
						1.5kW	GYC152D5-HB2					
					2.0kW	GYC202D5-HB2						
					With a brake	0.1kW	GYC101D5-HB2-B					
						0.2kW	GYC201D5-HB2-B					
						0.4kW	GYC401D5-HB2-B					
						0.75kW	GYC751D5-HB2-B					
						1.0kW	GYC102D5-HB2-B					
				1.5kW		GYC152D5-HB2-B						
				20-bit INC	Without a brake	0.1kW	GYC101D5-RB2					
						0.2kW	GYC201D5-RB2					
						0.4kW	GYC401D5-RB2					
						0.75kW	GYC751D5-RB2					
						1.0kW	GYC102D5-RB2					
						1.5kW	GYC152D5-RB2					
					2.0kW	GYC202D5-RB2						
					With a brake	0.1kW	GYC101D5-RB2-B					
						0.2kW	GYC201D5-RB2-B					
						0.4kW	GYC401D5-RB2-B					
						0.75kW	GYC751D5-RB2-B					
1.0kW	GYC102D5-RB2-B											
1.5kW	GYC152D5-RB2-B											
2.0kW	GYC202D5-RB2-B											
GYG motor (medium inertia)	200V	2000r/min	Without an oil seal and a key (*1)	18-bit ABS	Without a brake	0.5kW	GYG501C5-HB2					
						0.75kW	GYG751C5-HB2					
						1.0kW	GYG102C5-HB2					
						1.5kW	GYG152C5-HB2					
						2.0kW	GYG202C5-HB2					
						0.5kW	GYG501C5-HB2-B					
					0.75kW	GYG751C5-HB2-B						
					1.0kW	GYG102C5-HB2-B						
					1.5kW	GYG152C5-HB2-B						
					2.0kW	GYG202C5-HB2-B						
					20-bit INC	Without a brake	0.5kW	GYG501C5-RB2				
							0.75kW	GYG751C5-RB2				
				1.0kW			GYG102C5-RB2					
				1.5kW			GYG152C5-RB2					
				2.0kW			GYG202C5-RB2					
				0.5kW			GYG501C5-RB2-B					
				0.75kW		GYG751C5-RB2-B						
				1.0kW		GYG102C5-RB2-B						
				1.5kW		GYG152C5-RB2-B						
				2.0kW		GYG202C5-RB2-B						
				GYG motor (medium inertia)		200V	1500r/min	Without an oil seal and a key (*1)	18-bit ABS	Without a brake	0.5kW	GYG501B5-HB2
											0.85kW	GYG851B5-HB2
					1.3kW						GYG132B5-HB2	
					With a brake					0.5kW	GYG501B5-HB2-B	
0.85kW	GYG851B5-HB2-B											
1.3kW	GYG132B5-HB2-B											
20-bit INC	Without a brake	0.5kW	GYG501B5-RB2									
		0.85kW	GYG851B5-RB2									
		1.3kW	GYG132B5-RB2									
	With a brake	0.5kW	GYG501B5-RB2-B									
		0.85kW	GYG851B5-RB2-B									
		1.3kW	GYG132B5-RB2-B									
GYB motor (medium inertia)	200V	3000r/min	Without an oil seal and a key (*1)	18-bit ABS	Without a brake	0.2kW	GYB201D5-HB2					
						0.4kW	GYB401D5-HB2					
						0.75kW	GYB751D5-HB2					
					With a brake	0.2kW	GYB201D5-HB2-B					
						0.4kW	GYB401D5-HB2-B					
						0.75kW	GYB751D5-HB2-B					
				20-bit INC	Without a brake	0.2kW	GYB201D5-RB2					
						0.4kW	GYB401D5-RB2					
						0.75kW	GYB751D5-RB2					
					With a brake	0.2kW	GYB201D5-RB2-B					
						0.4kW	GYB401D5-RB2-B					
						0.75kW	GYB751D5-RB2-B					

*1: The motor with a shaft extension with a key and tapped is available as a semi-standard item. (See page 33 for shaft extension specifications.)
The other specifications are handled as a made-to-order item.

Model List

Option

■ Connector and cable

Name		Specifications	Type		
For main circuit of amplifier	Power supply connector (for amplifier control power and main power supply)	0.05 to 1.5kW (to 1.0kW with GYG)	1 set		
	DC circuit connector (wiring of external regenerative resistor, DC reactor, DC link circuit) *1	0.05 to 1.5kW (to 1.0kW with GYG)	1 set		
For sequence I/O (between host and amplifier)	Motor power connector (wiring of main motor power)	0.05 to 1.5kW (to 1.0kW with GYG)	1 set		
	Sequence I/O cable	All capacities	3m (bare wires on one side)		
For encoder (between amplifier and motor)	Sequence I/O connector kit *4	Amplifier side : All capacities	1 set		
		Encoder cable	3000r/min for 0.05 to 0.75kW		
		2m (connector at both ends)	WSC-P06P02-E		
		5m (connector at both ends)	WSC-P06P05-E		
	10m (connector at both ends)	WSC-P06P10-E			
	20m (connector at both ends)	WSC-P06P20-E			
Encoder connector kit *4	3000r/min for 1.0 to 5.0kW	5m (connector at both ends)	WSC-P06P05-C		
	2000r/min for 0.5 to 2.0kW	10m (connector at both ends)	WSC-P06P10-C		
	1500r/min for 0.5 to 1.3kW	20m (connector at both ends)	WSC-P06P20-C		
	Amplifier side : All capacities	1 set	WSK-P06P-M		
Motor side : 0.05 to 0.75kW	1 set	WSK-P09P-D			
Motor side : 0.5 to 5.0kW	1 set	WSK-P06P-C			
For motor power (between amplifier and motor)	Motor power cable	For main motor power *2	GYS, GYC, GYB : 0.05 to 0.75kW	2m (bare wires on one side)	WSC-M04P02-E
			5m (bare wires on one side)	WSC-M04P05-E	
			10m (bare wires on one side)	WSC-M04P10-E	
		For brake power *3	GYS, GYC, GYB : 0.05 to 0.75kW	2m (bare wires on one side)	WSC-M02P02-E
			5m (bare wires on one side)	WSC-M02P05-E	
			10m (bare wires on one side)	WSC-M02P10-E	
	Motor power connector kit	For main motor power *4	Motor side : GYS, GYC, GYB 0.05 to 0.75kW	1 set	WSK-M04P-E
			Motor side : GYS, GYC, GYB 0.05 to 0.75kW	1 set	WSK-M02P-E
		For main motor power *4	Motor side : GYS 1.0 to 2.0kW GYG 0.5 to 2.0kW	1 set	WSK-M04P-CA
			Motor side : GYS 3.0 to 5.0kW GYC 1.0 to 2.0kW	1 set	WSK-M04P-CB
		For main motor power + brake power *4	Motor side : GYS 1.0 to 2.0kW GYG 0.5 to 2.0kW	1 set	WSK-M06P-CA
			Motor side : GYS 3.0 to 5.0kW GYC 1.0 to 2.0kW	1 set	WSK-M06P-CB
For SX bus	SX bus cable	For VS and LS type servo amplifiers	0.3m (connector at both ends)	NP1C-P3	
			0.6m (connector at both ends)	NP1C-P6	
			0.8m (connector at both ends)	NP1C-P8	
			2m (connector at both ends)	NP1C-02	
			5m (connector at both ends)	NP1C-05	
			10m (connector at both ends)	NP1C-10	
			15m (connector at both ends)	NP1C-15	
			25m (connector at both ends)	NP1C-25	

*1: One connector is included in the accessory of the main body of the servo amplifier.

*2: Use this cable with motor power connector (on amplifier side) WSK-M03P-E.

*3: Use this cable as a brake cable of the motor equipped with a brake.

*4: Use this connector when the customer fabricates a cable at arbitrary length.

■ Common options

Specifications		Type	
ABS backup battery	Set of battery and case (*With case)	1 set	
	Battery (*Discrete replacement battery)	1 piece	
External regenerative resistor	200V	3000r/min for 0.05 to 0.4kW	WSR-401
		3000r/min for 0.75 to 1.5kW, 2000r/min for 0.5 to 1.0kW, 1500r/min for 0.5 to 0.85kW	WSR-152
		3000r/min for 2.0 to 3.0kW, 2000r/min 1.5 to 2.0kW, 1500r/min 1.3kW	DB11-2
		3000r/min for 4.0 to 5.0kW	DB22-2
	100V	3000r/min for 0.05 to 0.375kW	WSR-751
For PC loader connection	RS-232C - RS-485 conversion adaptor	—	
	Cable	For connection of RS-485 port of VV type servo amplifier *1 2m (connector at both ends)	
Servo operator *2	—	WSP-51	

*1: Prepare a marketed USB cable (A-B type) for the USB port.

*2: Use a commercially-available USB cable (USB-A ; USB-B, or USB-A ; mini-B) when connecting the servo operator to PC. Use a commercially-available LAN cable when connecting the servo operation to the servo amplifier.

This servo operator can only be used with VV type amplifier.

Service Network

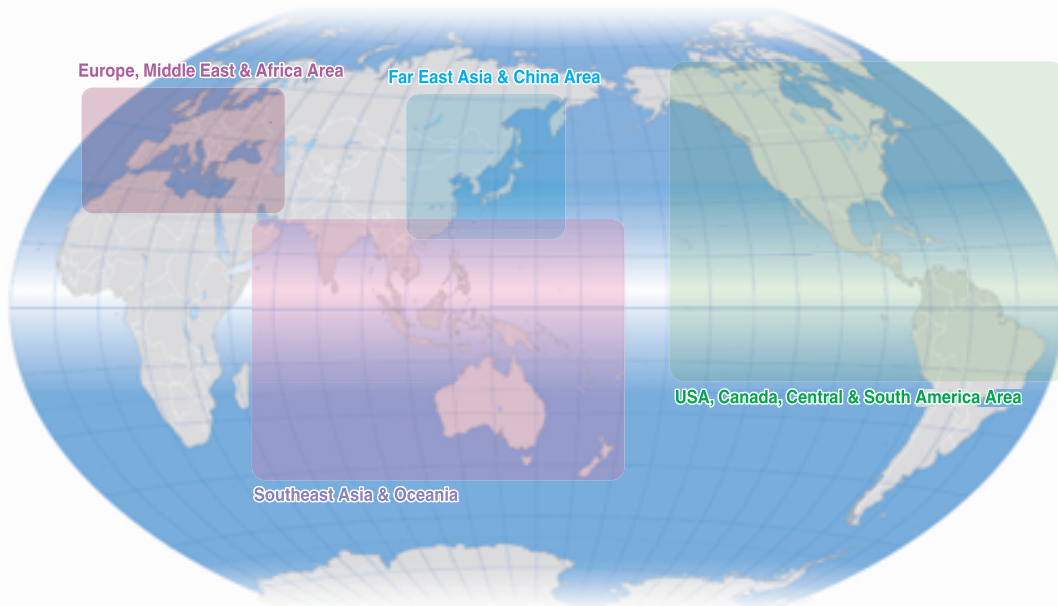

Fuji FA Service Centers

● Far East Asia

Overseas Service Center
Gate City Ohsaki, East Tower
11-2,Osaki 1-Chome,Shinagawa-ku
Tokyo,141-0032,Japan
Tel: +81-3-5435-7059
Fax: +81-3-5435-7447

■ Korea

● CANA ELECTRIC CO.,LTD.
501 Ewha Bldg., 8-21, Yangjae-Dong,
Seocho-Gu, Seoul, 137-887, Korea
Tel:+82-2-3462-0670
Fax:+82-2-3462-0678

■ Taiwan

● ELTA ELECTRICAL CO.,LTD.
4F, No.32, Sec.3, Cheng-Teh Road, Taipei, Taiwan
Tel:+886-2-2597-6458
Fax:+886-2-2595-4571

● FULL KEY SYSTEM CO., LTD.
12F, No.111-8, Hsing-Teh Road, San-Chung City, Taipei, Taiwan
Tel:+886-2-2995-2008
Fax:+886-2-2995-2028

● Europe,Middle East & Africa Area

EU Service Center
Goethering 58,63067 Offenbach/Main Germany
Tel: +49-69-66-90-29-0
Fax: +49-69-66-90-29-58

● China Area

FUJI ELECTRIC (CHINA) CO.,LTD.
Floor 28, International Corporate City,
No 3000 North Zhongshan Road
Shanghai China (P.C.200063)
Tel: +86-21-5496-1177
Fax: +86-21-6228-0350

● Southeast Asia & Oceania

Southeast Asia & Oceania Service Center
171 Chin Swee Road, #12-01 San Centre,
Singapore 169877
Tel: +65-6533-0014
Fax: +65-6533-0021

● USA,Canada,Cental & South America Area

USA Service Center
47520 Westinghouse Drive
Fremont,CA 94539,USA
Tel: +1-510-440-1060
Fax: +1-510-440-1063

Please access the URL below for further details:
http://www.fujielectric.co.jp/products/provide_data/drive/network/world/world-top.html

Product Warranty

■ To all our customers who purchase Fuji Electric products included in this catalog:

Please take the following items into consideration when placing your order.

When requesting an estimate and placing your orders for the products included in these materials, please be aware that any items such as specifications which are not specifically mentioned in the contract, catalog, specifications or other materials will be as mentioned below.

In addition, the products included in these materials are limited in the use they are put to and the place where they can be used, etc., and may require periodic inspection. Please confirm these points with your sales representative or directly with this company.

Furthermore, regarding purchased products and delivered products, we request that you take adequate consideration of the necessity of rapid receiving inspections and of product management and maintenance even before receiving your products.

1. Free of Charge Warranty Period and Warranty Range

1-1 Free of charge warranty period

- (1) The product warranty period is "1 year from the date of purchase" (both inside and outside Japan) or 18 months (inside Japan) 24 months (outside Japan) from the manufacturing time printed on the name plate, whichever comes first.
- (2) However, in cases where the use environment, conditions of use, use frequency and times used, etc., have an effect on product life, this warranty period may not apply.
- (3) Furthermore, the warranty period for parts restored by Fuji Electric's Service Department is "6 months from the date that repairs are completed."

1-2 Warranty range

- (1) In the event that breakdown occurs during the product's warranty period which is the responsibility of Fuji Electric, Fuji Electric will replace or repair the part of the product that has broken down free of charge at the place where the product was purchased or where it was delivered. However, if the following cases are applicable, the terms of this warranty may not apply.
 - 1) The breakdown was caused by inappropriate conditions, environment, handling or use methods, etc. which are not specified in the catalog, operation manual, specifications or other relevant documents.
 - 2) The breakdown was caused by the product other than the purchased or delivered Fuji's product.
 - 3) The breakdown was caused by the product other than Fuji's product, such as the customer's equipment or software design, etc.
 - 4) Concerning the Fuji's programmable products, the breakdown was caused by a program other than a program supplied by this company, or the results from using such a program.
 - 5) The breakdown was caused by modifications or repairs affected by a party other than Fuji Electric.
 - 6) The breakdown was caused by improper maintenance or replacement using consumables, etc. specified in the operation manual or catalog, etc.
 - 7) The breakdown was caused by a chemical or technical problem that was not foreseen when making practical application of the product at the time it was purchased or delivered.
 - 8) The product was not used in the manner the product was originally intended to be used.
 - 9) The breakdown was caused by a reason which is not this company's responsibility, such as lightning or other disaster.
- (2) Furthermore, the warranty specified herein shall be limited to the purchased or delivered product alone.
- (3) The upper limit for the warranty range shall be as specified in item (1) above and any damages (damage to or loss of machinery or equipment, or lost profits from the same, etc.) consequent to or resulting from breakdown of the purchased or delivered product shall be excluded from coverage by this warranty.

1-3. Trouble diagnosis

As a rule, the customer is requested to carry out a preliminary trouble diagnosis. However, at the customer's request, this company or its service network can perform the trouble diagnosis on a chargeable basis. In this case, the customer is asked to assume the burden for charges levied in accordance with this company's fee schedule.

2. Exclusion of Liability for Loss of Opportunity, etc.

Regardless of whether a breakdown occurs during or after the free of charge warranty period, this company shall not be liable for any loss of opportunity, loss of profits, or damages arising from special circumstances, secondary damages, accident compensation to another company, or damages to products other than this company's products, whether foreseen or not by this company, which this company is not be responsible for causing.

3. Repair Period after Production Stop, Spare Parts Supply Period (Holding Period)

Concerning models (products) which have gone out of production, this company will perform repairs for a period of 7 years after production stop, counting from the month and year when the production stop occurs. In addition, we will continue to supply the spare parts required for repairs for a period of 7 years, counting from the month and year when the production stop occurs. However, if it is estimated that the life cycle of certain electronic and other parts is short and it will be difficult to procure or produce those parts, there may be cases where it is difficult to provide repairs or supply spare parts even within this 7-year period. For details, please confirm at our company's business office or our service office.

4. Transfer Rights

In the case of standard products which do not include settings or adjustments in an application program, the products shall be transported to and transferred to the customer and this company shall not be responsible for local adjustments or trial operation.

5. Service Contents

The cost of purchased and delivered products does not include the cost of dispatching engineers or service costs. Depending on the request, these can be discussed separately.

6. Applicable Scope of Service

Above contents shall be assumed to apply to transactions and use of the country where you purchased the products. Consult the local supplier or Fuji for the detail separately.



SAFETY PRECAUTIONS

1. This catalog is intended for use in selecting required servo systems. Before actually using these products, carefully read their instruction manuals and understand their correct usage.
2. Products described in this catalog are neither designed nor manufactured for combined use with a system or equipment that will affect human lives.
If you are considering using these products for special purposes, such as atomic energy control, aerospace, medical application, or traffic control, please consult our sales office.
3. If you use our product with equipment that is expected to cause serious injury or damage to your property in case of failure, be sure to take appropriate safety measures for the equipment.

Fuji Electric Co., Ltd.

Gate City Ohsaki, East Tower, 11-2,
Osaki 1-chome, Shinagawa-ku,
Tokyo 141-0032, Japan
Phone: +81-3-5435-7057 Fax: +81-3-5435-7420
URL: <http://www.fujielectric.com/>