

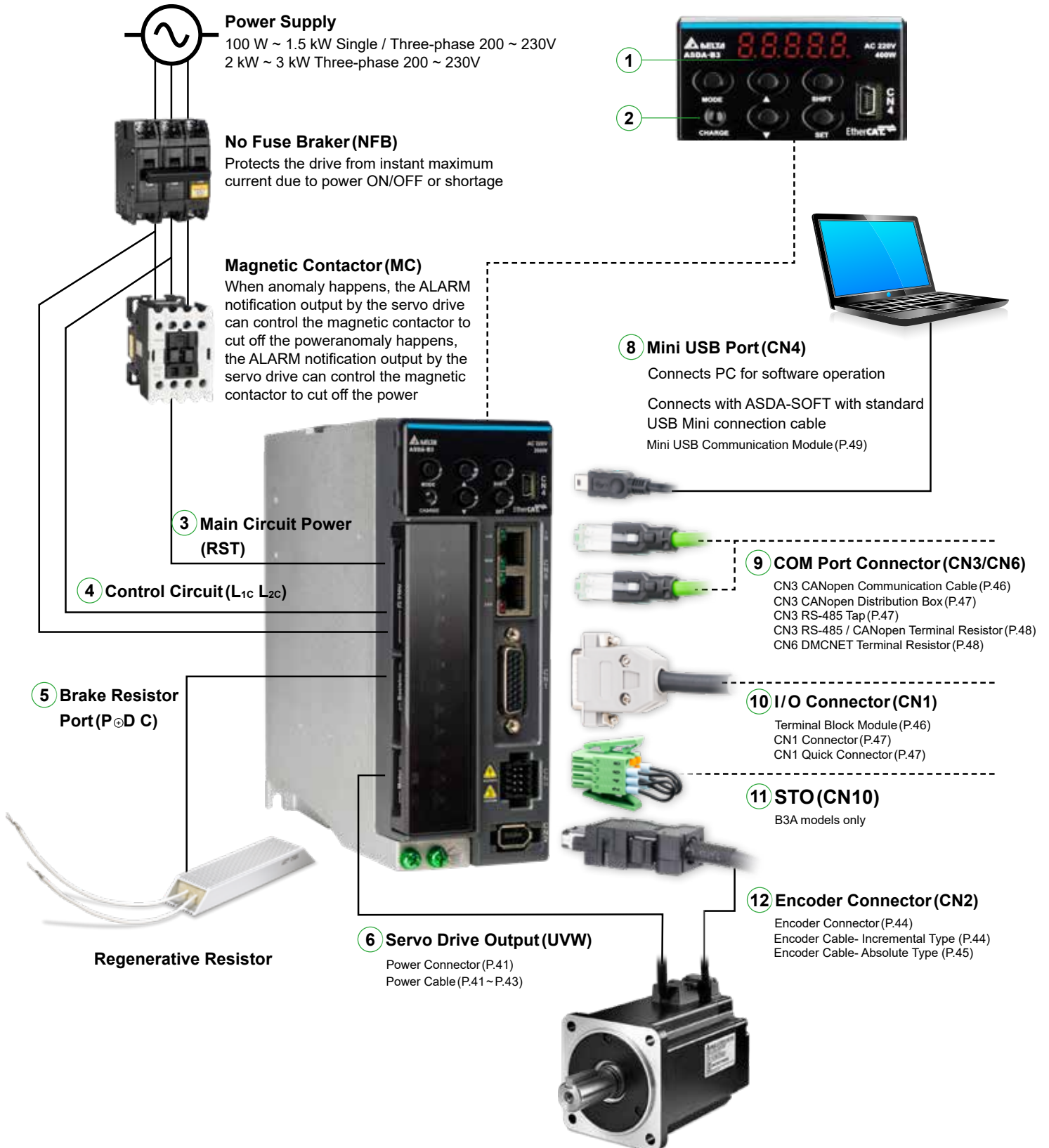

Automation for a Changing World

Delta AC Servo Drive & Motor ASDA-B3 Series

Servo Drive & Accessories



Servo Drive Interface

No.	Name	Description
①	-	7-segment display
②	CHARGE	Power indicator
③	RST	Main circuit terminal; connects to the power supply (200 - 230 V _{AC} , 50/60 Hz)
④	L1C, L2C	Control circuit terminal; connects to single-phase power supply (200 - 230 V _{AC} , 50/60 Hz)
⑤	Regenerative Resistor	Connects to an external regenerative resistor, external regenerative braking unit, or the built-in regenerative resistor
⑥	UVW	Servo drive current output; connects to the motor power connector U, V, W. Do not connect to the main circuit power. Incorrect wiring will cause damage to the servo drive.
⑦	Ground Terminal	Connects to the ground wire for the power and servo motor
⑧	CN4	USB connector (Mini USB); connects to PC
⑨	CN3	Modbus communication port (B3-L)
	CN3	CANopen high-speed communication port (B3-M)
	CN6	DMCNET high-speed communication port (B3-F)
	CN6	EtherCAT high-speed communication port (B3-E)
⑩	CN1	I/O signal interface; connects to the PLC or controls I/O
⑪	CN10	STO connector; only available on B3A models
⑫	CN2	Encoder connector; connects to the encoder of the servo motors

Accessories

Power Cables

- 3m, 5m, 10m, and 20m standard cables are available
- Standard power connector and IP67 waterproof connector are available
- With options of brake and without brake

Encoder Cables

- 3m, 5m, 10m, and 20m standard cables are available
- Standard power connector and IP67 waterproof connector are available

USB Cables

- Connects the PC and the servo drive for ASDA-Soft operation
- USB1.1 is equipped as standard interface

Regenerative Resistor

- Refer to Section 2.7 in the ASDA-B3 user manual for selection

Servo System Combination Table

		Motor					Drive		Power Cable	
Type	Power Supply	Output (W)	Model Name	Rotor Inertia (x10 ⁻⁴ kg.m ²) Standard/ With Brake	Rated / Max. Speed (rpm)	Rated / Max. Torque (N-m)	Model Name	Standard	Torsion-resistant	
Low Inertia	ECM-A3L	50	ECM-A3L-C [2] 040F [3][4][5]	0.0229/0.0255	3000/6000	0.159/0.557	ASD-B3 ① -0121-②	ACS3-CAPW31XX W ACS3-CAPW3AXX	ACS3-CAPF31XX W ACS3-CAPF3AXX	
		100	ECM-A3L-C [2] 0401 [3][4][5]	0.04/0.0426		0.32/1.12				
		200	ECM-A3L-C [2] 0602 [3][4][5]	0.09/0.12		0.64/2.24	ASD-B3 ① -0221-②			
		400	ECM-A3L-C [2] 0604 [3][4][5]	0.15/0.18		1.27/4.45	ASD-B3 ① -0421-②			
		400	ECM-A3L-C [2] 0804 [3][4][5]	0.352/0.408		1.27/4.44				
	ECM-B3L	750	ECM-A3L-C [2] 0807 [3][4][5]	0.559/0.614		2.39/8.36	ASD-B3 ① -0721-② ASD-B3 ① -1021-②			
		100	ECM-B3L-C [2] 0401 [3][4][5]	0.0299/0.0315		0.32/1.12	ASD-B3 ① -0121-②			
		200	ECM-B3M-C [2] 0602 [3][4][5]	0.141/0.151		0.64/2.24	ASD-B3 ① -0221-②			
		400	ECM-B3M-C [2] 0604 [3][4][5]	0.254/0.264		1.27/4.45	ASD-B3 ① -0421-②			
		400	ECM-B3M-C [2] 0804 [3][4][5]	0.648/0.695		1.27/4.45				
Medium Inertia	ECM-B3M	750	ECM-B3M-C [2] 0807 [3][4][5]	1.07/1.13	2.4/8.4	ASD-B3 ① -0721-②	ACS3-CAPW32XX	ACS3-CAPF32XX		
		1000	ECM-B3M-E [2] 1310 [3][4][5]	7.79/7.94	4.77/14.3	ASD-B3 ① -1021-②				
		1500	ECM-B3M-E [2] 1315 [3][4][5]	11.22/11.37	7.16/21.48	ASD-B3 ① -1521-②				
		2000	ECM-B3M-E [2] 1320 [3][4][5]	14.65/14.8	9.55/28.65	ASD-B3 ① -2023-②				
		2000	ECM-B3M-E [2] 1820 [3][4][5]	29.11/30.38	9.55/28.65					
	ECM-B3F	3000	ECM-B3M-F [2] 1830 [3][4][5]	53.63/54.9	1500/3000	19.1/57.29	ASD-B3 ① -3023-②	ACS3-CAPW34XX	ACS3-CAPF34XX	
		High Inertia	ECM-A3H	Single- / Three- phase	50	ECM-A3H-C [2] 040F [3][4][5]	0.0455/0.0517	0.159/0.557	ASD-B3 ① -0121-②	ACS3-CAPW31XX W ACS3-CAPW3AXX
100	ECM-A3H-C [2] 0401 [3][4][5]	0.0754/0.0816			0.32/1.12					
200	ECM-A3H-C [2] 0602 [3][4][5]	0.25/0.28			0.64/2.24	ASD-B3 ① -0221-②				
400	ECM-A3H-C [2] 0604 [3][4][5]	0.45/0.48			1.27/4.45	ASD-B3 ① -0421-②				
400	ECM-A3H-C [2] 0804 [3][4][5]	0.92/1.07			1.27/4.44					
750	ECM-A3H-C [2] 0807 [3][4][5]	1.51/1.66			2.39/8.36	ASD-B3 ① -0721-②				

Note:

- Model name with W = IP67 water-proof connector; D = drive connector; M = motor connector; S = straight connector; R = angular connector; B = single brake connector, power connector required
- Cable model name: The "XX" stands for cable length. 03 = 3 m, 05 = 5 m, 10 = 10 m, 20 = 20 m.
- Servo motor model name: [2] = encoder type, [3] = type of shaft and oil seal, [4] = shaft diameter and connector type, [5] = special code.
- Servo drive model name: ① = product series, ② = model code.

Connector & Cable						Cable Only (No Connector)		
Power Cable with Brake		Encoder Cable (Incremental Type)		Encoder Cable (Absolute Type)		Power Connector	Power Connector (with brake)/ Brake Connector	Encoder Connector
Standard	Torsion-resistant	Standard	Torsion-resistant	Standard	Torsion-resistant			
ACS3-CAPW41XX ACS3-CAPW4AXX	ACS3-CAPF41XX W ACS3-CAPF4AXX	ACS3-CAEN10XX W ACS3-CAEN2AXX	ACS3-CAEF10XX W ACS3-CAEF2AXX	ACS3-CAEA10XX W ACS3-CAEA2AXX	ACS3-CAEB10XX W ACS3-CAEB2AXX	ASDBCAPW0000 W ACS3-CNPW1A00	ASDBCAPW0100 W ACS3-CNPW2A00	D ACS3-CNENC200 + M ACS3-CNEN1000 M W ACS3-CNEN2A00
ACS3-CAPW42XX	ACS3-CAPF42XX	ACS3-CAEN27XX	ACS3-CAEF27XX	ACS3-CAEA27XX	ACS3-CAEB27XX	S ACS3-CNPW5200 R ACS3-CNPW5C00 R ACS3-CNPW5C00	S ACS3-CNPW5200 R ACS3-CNPW5C00 + B S ACS3-CNPW6300 B R ACS3-CNPW6D00	D ACS3-CNENC200 + M S ACS3-CNEN2700 M R ACS3-CNEN2C00
ACS3-CAPW44XX	ACS3-CAPF44XX							
ACS3-CAPW41XX ACS3-CAPW4AXX	ACS3-CAPF41XX W ACS3-CAPF4AXX	ACS3-CAEN10XX W ACS3-CAEN2AXX	ACS3-CAEF10XX W ACS3-CAEF2AXX	ACS3-CAEA10XX W ACS3-CAEA2AXX	ACS3-CAEB10XX W ACS3-CAEB2AXX	ASDBCAPW0000 W ACS3-CNPW1A00	ASDBCAPW0100 W ACS3-CNPW2A00	D ACS3-CNENC200 + M ACS3-CNEN1000 M W ACS3-CNEN2A00

Servo Drive Model Name

ASD-B3 Series Servo Drive

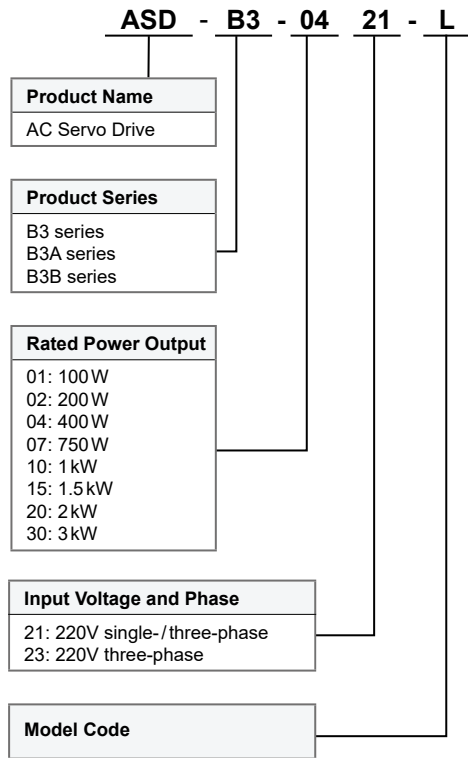

ASD-B3

Code	PT Mode Pulse Input	PR Mode	RS-485	Analog Voltage Control	CANopen	DMCNET	EtherCAT	STO
L	○	○	○	○	X	X	X	X
M	X	○	X	○	○	X	X	X
F	X	○	X	○	X	○	X	X
E	X	○	X	○	X	X	○	X

ASD-B3A *1

Code	PT Mode Pulse Input	PR Mode	RS-485	Analog Voltage Control	CANopen	DMCNET	EtherCAT	STO ²
L	○	○	○	○	X	X	X	○
M	○	○	○	○	○	X	X	○
F	○	○	X	○	X	○	X	○
E	○	○	X	○	X	X	○	○



ASD-B3B *3

Code	PT Mode Pulse Input	PR Mode	RS-485	Analog Voltage Control	CANopen	DMCNET	EtherCAT	STO
L	○	X	○	○	X	X	X	X

*1: This series has the dynamic brake function
 *2: STO certification pending
 *3: Coming soon



Servo Drive Specifications

ASD-B3		100 W 01	200 W 02	400 W 04	750 W 07	1 kW 10	1.5 kW 15	2 kW 20	3 kW 30	
Power Supply	Phase / Voltage	Single-phase / Three-phase 220V _{AC}						Three-phase 220V _{AC}		
	Permissible Voltage	Single-phase / Three-phase 200 - 230V _{AC} , -15% to 10%						Three-phase 200 - 230V _{AC} , -15% to 10%		
	Input Current (3PH) (Unit: Arms)	0.81	1.61	4.32	8.76	9.21	9.72	14.7	16.68	
	Input Current (1PH) (Unit: Arms)	1.39	2.77	8.28	16.68	17.49	18.72			
	Continuous Output Current (Unit: Arms)	0.9	1.55	2.65	5.1	7.3	8.3	13.4	19.4	
	Max. Instantaneous Output Current (Unit: Arms)	3.88	7.07	10.6	16.4	21.21	27	38.3	58.9	
Cooling Method	Natural cooling					Fan cooling				
Drive Resolution	24-bit (16,777,216 pls/rev)									
Main Circuit Control	SVPWM control									
Tuning Mode	Auto / Manual									
Regenerative Resistor	N/A			Built-in						
Position Control Mode	Pulse Type (only for pulse control mode)	Pulse + Direction; A phase + B phase; CCW pulse + CW pulse								
	Max. Output Pulse Frequency (only for pulse control mode)	Pulse + direction: 4 Mpps; CCW pulse + CW pulse: 4 Mpps; A phase + B phase: single-phase 4 Mpps; Open collector: 200 Kpps								
	Command Source	External pulse (only for pulse control mode) / Internal register (PR mode)								
	Smoothing Method	Low-pass, S-curve, and moving filters								
	E-Gear Ratio	E-Gear ratio: N / M times, limited to (1 / 4 < N / M < 262144) N: 1 - 536870911/M: 1 - 2147483647								
	Torque Limit	Parameter settings								
Feed Forward Compensation	Parameter settings									
Speed Control Mode	Analog Command Input	Voltage Range	0 to ±10 V _{DC}							
		Resolution	12-bit							
		Input Impedance	1 MΩ							
		Time Constant	25 μs							
	Speed Control Range ¹	1 : 6000								
	Command Source	External analog command / Internal register								
Smoothing Method	Low-pass and S-curve filters									
Torque Limit	Parameter settings or analog input									
Bandwidth	Maximum 3.1 kHz									
Speed Calibration Ratio ²	±0.01% at 0% to 100% load fluctuation									
	±0.01% at ±10% power fluctuation									
	±0.01% at 0°C to 50°C ambient temperature fluctuation									
Torque Control Mode	Analog Command Input	Voltage Range	0 to ±10 V _{DC}							
		Input Impedance	1 MΩ							
		Time Constant	25 μs							
	Command Source	External analog command / Internal register								
Smoothing Method	Low-pass filter									
Speed Limit	Parameter settings or analog input									
Analog Monitor Output	Monitoring signal can be set with parameters (voltage output range: ±8V); resolution: 10-bit									
Digital Input / Output	Input	Servo on, Fault reset, Gain switch, Pulse clear, Zero speed clamping, Command input reverse control, Internal position command trigger, Torque limit, Speed limit, Internal position command selection, Motor stop, Speed command selection, Speed / Position mode switching, Speed / Torque command switching, Torque / Position mode switching, PT / PR command switching, Emergency stop, Forward / reverse limit, Original point, Forward / reverse operation torque limit, Homing activated, Forward / reverse JOG input, Event trigger, E-Gear N selection, Pulse input prohibition *The DI mentioned above are only used in pulse control mode. When controlling through communication, it is suggested that you use communication for DI input. DI only supports emergency stop, forward / reverse limit, and homing.								
	Output	A, B, Z line driver output Servo ready, Servo on, Zero speed detection, Target speed reached, Target position reached, Torque limiting, Servo alarm, Magnetic brake control, Homing complete, Early warning for overload, Servo warning, Position command overflows, Software limit (reverse direction), Software limit (forward direction), Internal position command complete, Servo procedure complete, Capture procedure complete								
Protection Function	Overcurrent, Overvoltage, Undervoltage, Overheat, Regeneration error, Overload, Excessive speed deviation, Excessive position deviation, Encoder error, Adjustment error, Emergency stop, Forward / reverse limit error, Serial communication error, RST leak phase, Serial communication timeout, Short-circuit protection for terminals U, V, W									
Communication Interface	USB/RS-485/CANopen/DMCNET/EtherCAT									
Environment	Installation Site	Indoors (avoid direct sunlight), no corrosive vapor (avoid fumes, flammable gases, and dust)								
	Altitude	Altitude 2000 m or lower above sea level								
	Atmospheric Pressure	86 kPa - 106 kPa								
	Operating Temperature	0°C to 55°C (if operating temperature is above 45°C, forced cooling is required)								
	Storage Temperature	-20°C to 65°C								
	Humidity	0 to 90% RH (non-condensing)								
	Vibration	9.80665 m/s ² (1 G) less than 20 Hz, 5.88 m/s ² (0.6 G) 20 to 50 Hz								
	IP Rating	IP20								
Power System	TN system ^{*3,4}									
Certifications	IEC/EN 61800-5-1, UL 508C  									

Note:

*1. Within the rated load, the speed ratio is: the minimum speed (smooth operation) / rated speed.

*2. Within the rated speed, the speed calibration ratio is: (rotational speed with no load - rotational speed with full load) / rated speed.

*3. TN system: the neutral point of the power system connects directly to the ground. The exposed metal components connect to the ground through the protective ground conductor.

*4. Use a single-phase three-wire power system for the single-phase power model.

Servo Drive Specifications

Dimensions

100 W / 200 W / 400 W

Weight	Unit: mm (inch)
0.9 kg	

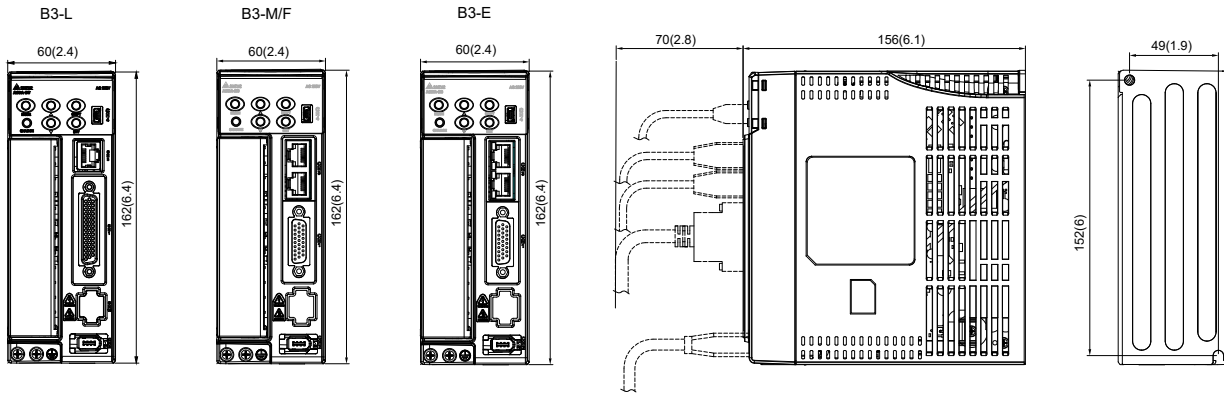

750 W

Weight	Unit: mm (inch)
1.2 kg	

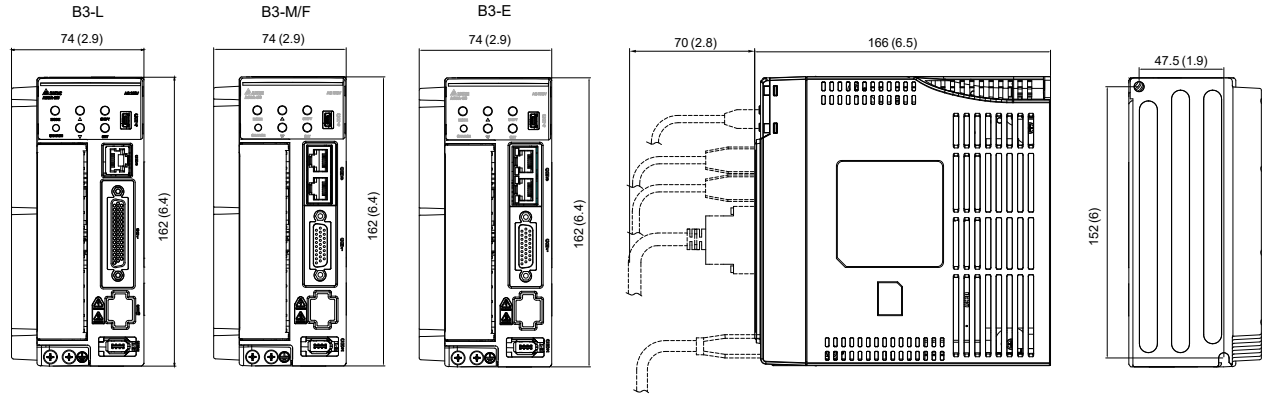

1 kW / 1.5 kW

Weight	Unit: mm (inch)
1.8 kg	

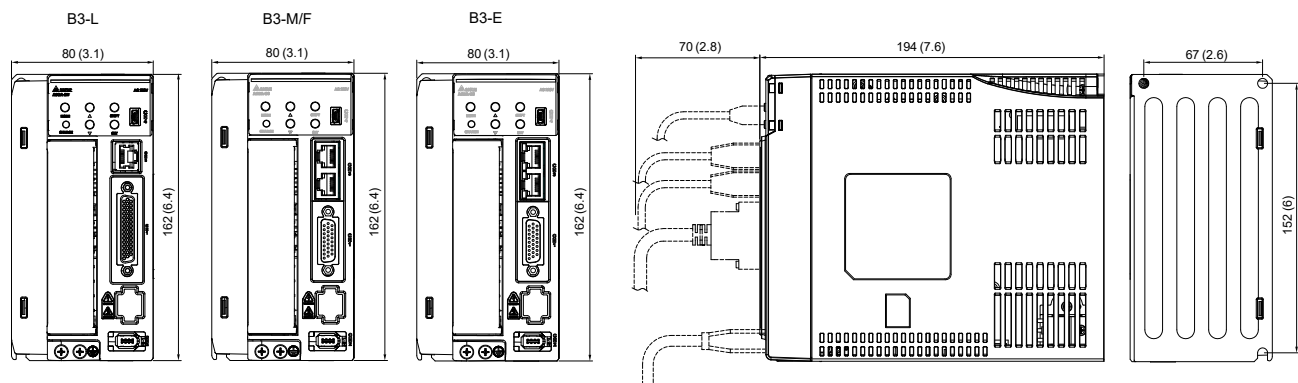

2 kW/3 kW

Weight
2.8 kg

Unit: mm (inch)

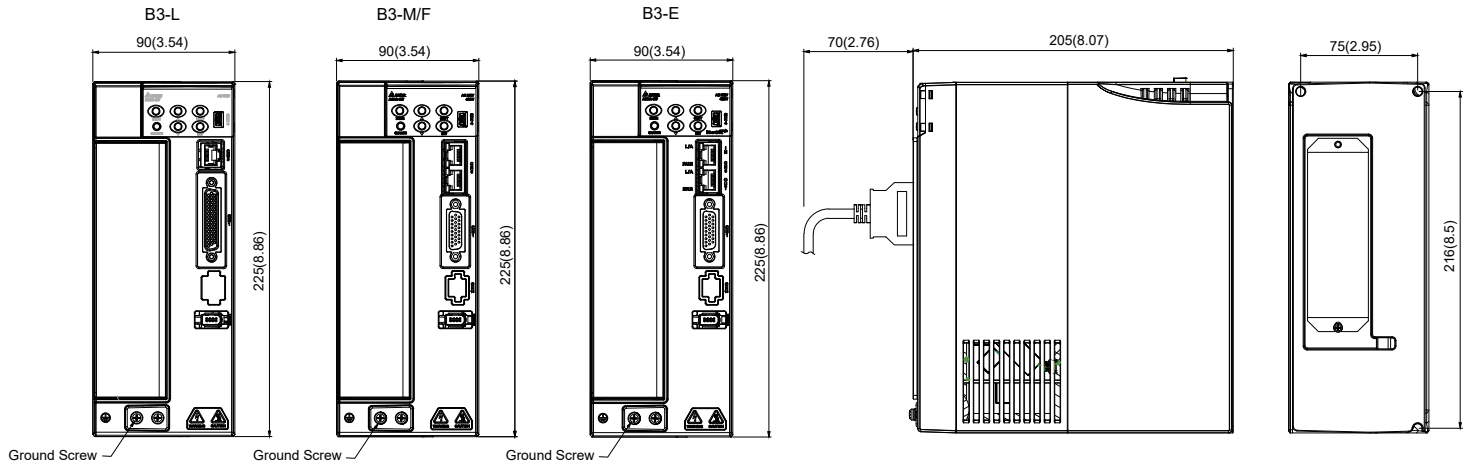

Regenerative Resistor Specifications

Servo Drive (kW)	Specifications of the Built-In Regenerative Resistor		Capacity of the Built-In Regenerative Resistor (Watt)	Minimum Allowable Resistance Value (Ohm) (reference for external resistors)
	Resistance (Ohm)	Capacity (Watt)		
0.1	-	-	-	60
0.2	-	-	-	60
0.4	100	40	20	60
0.75	100	40	20	60
1.0	100	40	20	30
1.5	100	40	20	30
2.0	20	80	40	15
3.0	20	80	40	15

Servo Motor Model Name

ECM-B3 Series Servo Motor

ECM - B3 M - C A 06 04 R S 1

Product Name
ECM:
Electronic
Commutation Motor

Series
B3 series

Inertia
M: Medium inertia
L: Low inertia

Rated Voltage and Speed
C: 220V/3000 rpm
E: 220V/2000 rpm
F: 220V/1500 rpm

Encoder Type
A: 24-bit absolute magnetic optical encoder
Resolution of single turn: 24-bit
Resolution of multiple turns^{*1}: 16-bit
2: 24-bit incremental magnetic optical encoder^{*2}
P: 17-bit absolute magnetic encoder
Resolution of single turn: 17-bit
Resolution of multiple turns^{*1}: 16-bit
M: 17-bit incremental magnetic encoder^{*2}

^{*1}. Number of turns.
^{*2}. Can be used as a single-turn absolute encoder.

Motor Frame Size
04: 40 mm 06: 60 mm
08: 80 mm 13: 130 mm
18: 180 mm

Rated Power Output
01: 100 W 02: 200 W
04: 400 W 07: 750 W
10: 1 kW 15: 1.5 kW
20: 2 kW 30: 3 kW

Type of Shaft and Oil Seal	w/o Brake w/o Oil Seal	with Brake w/o Oil Seal	w/o Brake with Oil Seal	with Brake with Oil Seal
Round Shaft (with fixed screw holes)	-	-	C*	D*
Keyway (with fixed screw holes)	P*	Q*	R	S

Note: Models with an * are coming soon.

Shaft Diameter
S: Standard connector and standard shaft diameter
7: Standard connector and special shaft diameter (14 mm)*
J: IP67 waterproof connector and standard shaft diameter
K: IP67 waterproof connector and special shaft diameter (14 mm)*

*Shafts of special diameter are used for 400 W motors with the frame size of 80 mm.

Special Code
1: Standard products

ECM-A3 Series Servo Motor

ECM - A3 H - C Y 06 04 R S 1

Product Name
ECM:
Electronic
Commutation Motor

Series
A3 series

Inertia
H: High inertia
L: Low inertia

Rated Voltage and Speed
C: 220V/3000 rpm

Encoder Type
Y: 24-bit absolute optical encoder
Resolution of single turn: 24-bit
Resolution of multiple turns^{*1}: 16-bit
1: 24-bit incremental optical encoder^{*2}
A: 24-bit absolute magnetic optical encoder
Resolution of single turn: 24-bit
Resolution of multiple turns^{*1}: 16-bit
2: 24-bit incremental magnetic optical encoder^{*2}

^{*1}. Number of turns.
^{*2}. Can be used as a single-turn absolute encoder.

Motor Frame Size
04: 40 mm 06: 60 mm
08: 80 mm

Rated Power Output
0F: 50 W 01: 100 W
02: 200 W 04: 400 W
07: 750 W

Type of Shaft and Oil Seal	w/o Brake w/o Oil Seal	with Brake w/o Oil Seal	w/o Brake with Oil Seal	with Brake with Oil Seal
Round Shaft (with fixed screw holes)	-	-	C	D
Keyway (with fixed screw holes)	P*	Q*	R	S

*Note: Models with an * are coming soon.

Shaft Diameter
S: Standard connector and standard shaft diameter
7: Standard connector and special shaft diameter (14 mm)*
J: IP67 waterproof connector and standard shaft diameter
K: IP67 waterproof connector and special shaft diameter (14 mm)*



*Shafts of special diameter are used for 400 W motors with the frame size of 80 mm.

Special Code
1: Standard products
Z: Refer to the note for dimensions on page 33

ECM-B3 Series Servo Motor Specifications

Electrical Specifications

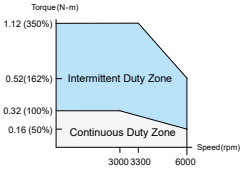
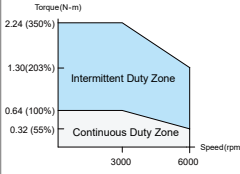
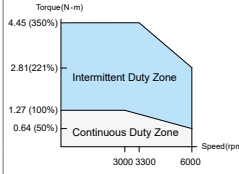
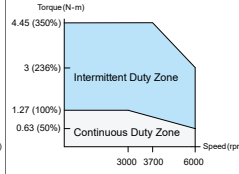
Low Inertia Motor ECM-B3L Series / Medium Inertia Motor ECM-B3M Series

	ECM-B3L-C 2 0401 ^{*1}	ECM-B3M-C 2 0602 ^{*1}	ECM-B3M-C 2 0604 ^{*1}	ECM-B3M-C 2 0804 ^{*1}
Rated Power (kW)	0.1	0.2	0.4	0.4
Rated Torque (N-m) ²	0.32	0.64	1.27	1.27
Maximum Torque (N-m)	1.12	2.24	4.45	4.45
Rated Speed (rpm)	3000			
Maximum Speed (rpm)	6000			
Rated Current (Arms)	0.857	1.42	2.40	2.53
Max. Instantaneous Current (Arms)	3.44	6.62	9.47	9.42
Rated Power Rate (kW/s) ³	34.25 (32.51)	29.05 (27.13)	63.50 (61.09)	24.89 (23.21)
Rotor Inertia ($\times 10^{-4}$ kg.m ²) ³	0.0299 (0.0315)	0.141 (0.151)	0.254 (0.264)	0.648 (0.695)
Mechanical Time Constant (ms) ³	0.50 (0.53)	0.91 (0.97)	0.52 (0.54)	0.8 (0.86)
Torque Constant -KT (N-m/A)	0.374	0.45	0.53	0.5
Voltage Constant -KE (mV/(rpm))	13.8	16.96	19.76	18.97
Armature Resistance (Ohm)	8.22	4.71	2.04	1.125
Armature Inductance (mH)	19.1	12.18	6.50	5.14
Electrical Time Constant (ms)	2.32	2.59	3.19	4.57
Brake Holding Torque [Nt-m (min)] ⁴	0.3	1.3	1.3	2.5
Brake Power Consumption (at 20°C)[W]	6.1	7.6	7.6	8
Brake Release Time [ms (Max.)]	20	20	20	20
Brake Pull-In Time [ms (Max.)]	35	50	50	60
Max. Radial Loading (N) ⁶	78	245	245	392
Max. Axial Loading (N) ⁶	54	74	74	147
Weight (kg) ³	0.5 (0.7)	0.9 (1.3)	1.2 (1.6)	1.7 (2.51)
Derating (%) (with oil seal)	10	10	5	5
Torque Feature (T-N Curve)				
Insulation Class	Class A (UL), Class B (CE)			
Insulation Resistance	> 100 MΩ, DC 500V			
Insulation Strength	1.8 kVac, 1 sec			
Vibration Level (μm)	V15			
Operating Temperature	-20°C ~ 60°C ⁵			
Storage Temperature	-20°C ~ 80°C ⁵			
Storage & Operation Humidity	20 ~ 90%RH (non-condensing)			
Vibration Capacity	2.5 G			
IP Rating	IP67 (when using waterproof connections and when an oil seal is fitted to the rotating shaft (for an oil seal model))			
Certifications				

Note:

- In the servo motor model name, [1] represents the motor inertia and [2] represents the encoder type.
- The rated torque is the continuous permissible torque between 0 to 40°C operating temperature which is suitable for the servo motor mounted with the following heat sink dimensions.
F40, F60, F80: 250 mm x 250 mm x 6 mm
Material: aluminum
- () = motor with brake
- The built-in servo motor brake is only for keeping the object in a stopped state.
Do not use it for deceleration or as a dynamic brake
- If the operating temperature is over 40°C, refer to the power derating curves of B3 motors on page 27.

- Please follow the max. tolerating loading of the motor shaft end listed below during operation

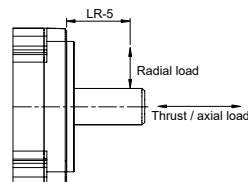

ECM-B3 Series Servo Motor Specifications

Electrical Specifications

Medium Inertia Motor ECM-B3M Series

	ECM-B3-C [2] 0807 ^{*1}	ECM-B3-E [2] 1310 ^{*1}	ECM-B3-E [2] 1315 ^{*1}	ECM-B3-E [2] 1320 ^{*1}
Rated Power (kW)	0.75	1	1.5	2
Rated Torque (N-m) ²	2.4	4.77	7.16	9.55
Maximum Torque (N-m)	8.4	14.3	21.48	28.65
Rated Speed (rpm)	3000		2000	
Maximum Speed (rpm)	6000		3000	
Rated Current (Arms)	4.27	5.96	8.17	10.59
Max. Instantaneous Current (Arms)	15.8	19.9	26.82	34.20
Rated Power Rate (kW/s) ³	53.83(50.97)	29.21 (28.66)	45.69 (45.09)	62.25 (61.62)
Rotor Inertia ($\times 10^{-4}$ kg.m ²) ³	1.07 (1.13)	7.79 (7.94)	11.22 (11.37)	14.65 (14.8)
Mechanical Time Constant (ms) ³	0.54 (0.57)	1.46 (1.49)	1.10 (1.12)	1.03 (1.04)
Torque Constant -KT (N-m/A)	0.56	0.80	0.88	0.90
Voltage Constant -KE (mV/(rpm))	20.17	29.30	31.69	32.70
Armature Resistance (Ohm)	0.55	0.419	0.260	0.198
Armature Inductance (mH)	2.81	4	2.81	2.18
Electrical Time Constant (ms)	5.11	9.55	10.81	11.01
Brake Holding Torque [Nt-m (min)] ⁴	2.5	10	10	10
Brake Power Consumption (at 20°C)[W]	8	21.5	21.5	21.5
Brake Release Time [ms (Max.)]	20	50	50	50
Brake Pull-In Time [ms (Max.)]	60	110	110	110
Max. Radial Loading (N) ⁶	392	490	686	980
Max. Axial Loading (N) ⁶	147	98	343	392
Weight (kg) ³	2.34 (3.15)	4.9 (6.3)	6.0 (7.4)	7 (8.5)
Derating (%) (with oil seal)	5	5	5	5

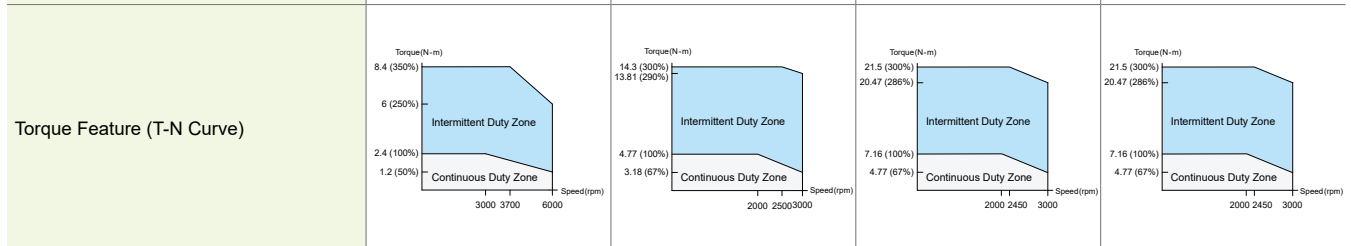

Insulation Class	Class A (UL), Class B (CE)
Insulation Resistance	> 100 MΩ, DC 500V
Insulation Strength	1.8 kVac, 1 sec
Vibration Level (μm)	V15
Operating Temperature	-20°C ~ 60°C*5
Storage Temperature	-20°C ~ 80°C*5
Storage & Operation Humidity	20 ~ 90%RH (non-condensing)
Vibration Capacity	2.5 G
IP Rating	IP67 (when using waterproof connections and when an oil seal is fitted to the rotating shaft (for an oil seal model))
Certifications	

Note:

- In the servo motor model name, [] represents the motor inertia and [2] represents the encoder type.
- The rated torque is the continuous permissible torque between 0 to 40°C operating temperature which is suitable for the servo motor mounted with the following heat sink dimensions.
F80: 250 mm x 250 mm x 6 mm
F130: 400 mm x 400 mm x 20 mm
Material: aluminum
- () = motor with brake
- The built-in servo motor brake is only for keeping the object in a stopped state.
Do not use it for deceleration or as a dynamic brake
- If the operating temperature is over 40°C, refer to the power derating curves of B3 motors on page 27.

- Please follow the max. tolerant loading of the motor shaft end listed below during operation

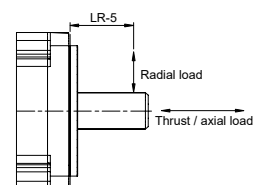

Medium Inertia Motor ECM-B3M Series

ECM-B3 [1]	ECM-B3M-E [2] 1820*1	ECM-B3M-F [2] 1830*1
Rated Power (kW)	2	3
Rated Torque (N-m) ²	9.55	19.1
Maximum Torque (N-m)	28.65	57.29
Rated Speed (rpm)	2000	1500
Maximum Speed (rpm)	3000	3000
Rated Current (Arms)	11.43	18.21
Max. Instantaneous Current (Arms)	36.21	58.9
Rated Power Rate (kW/s) ³	31.33 (30.02)	68.02 (66.45)
Rotor Inertia ($\times 10^{-4}$ kg.m ²) ³	29.11 (30.38)	53.63 (54.9)
Mechanical Time Constant (ms) ³	1.74 (1.81)	1.21 (1.24)
Torque Constant -KT (N-m/A)	0.88	1.05
Voltage Constant -KE (mV/(rpm))	31.6	37.9
Armature Resistance (Ohm)	0.159	0.086
Armature Inductance (mH)	2.34	1.52
Electrical Time Constant (ms)	14.72	17.67
Brake Holding Torque [Nt-m (min)] ⁴	25	25
Brake Power Consumption (at 20°C)[W]	31	31
Brake Release Time [ms (Max.)]	30	30
Brake Pull-In Time [ms (Max.)]	120	120
Max. Radial Loading (N) ⁶	1470	1470
Max. Axial Loading (N) ⁶	490	490
Weight (kg) ³	10 (13.7)	13.9 (17.6)
Derating (%) (with oil seal)	5	5
Torque Feature (T-N Curve)		
Insulation Class	Class A (UL), Class B (CE)	
Insulation Resistance	> 100 MΩ, DC 500V	
Insulation Strength	1.8 kVac, 1 sec	
Vibration Level (μm)	V15	
Operating Temperature	-20°C ~ 60°C*5	
Storage Temperature	-20°C ~ 80°C*5	
Storage & Operation Humidity	20 ~ 90%RH (non-condensing)	
Vibration Capacity	2.5 G	
IP Rating	IP67 (when using waterproof connections and when an oil seal is fitted to the rotating shaft (for an oil seal model))	
Certifications		

- Note:
- In the servo motor model name, [1] represents the motor inertia and [2] represents the encoder type.
 - The rated torque is the continuous permissible torque between 0 to 40°C operating temperature which is suitable for the servo motor mounted with the following heat sink dimensions.
F180 : 550 mm x 550 mm x 30 mm
Material: aluminum
 - () = motor with brake
 - The built-in servo motor brake is only for keeping the object in a stopped state.
Do not use it for deceleration or as a dynamic brake
 - If the operating temperature is over 40°C, refer to the power derating curves of B3 motors on page 27.
 - Please follow the max. tolerant loading of the motor shaft end listed below during operation

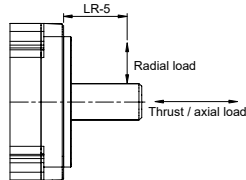

ECM-B3 Series Servo Motor Specifications

Power Derating Curves

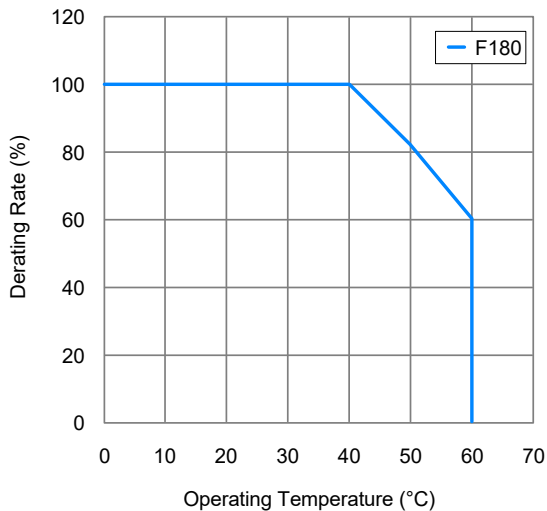
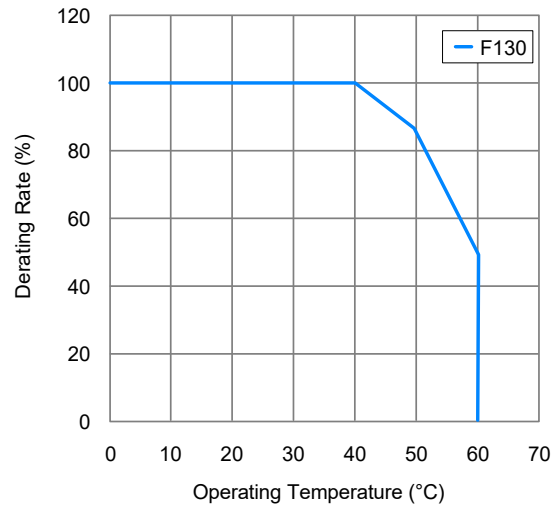
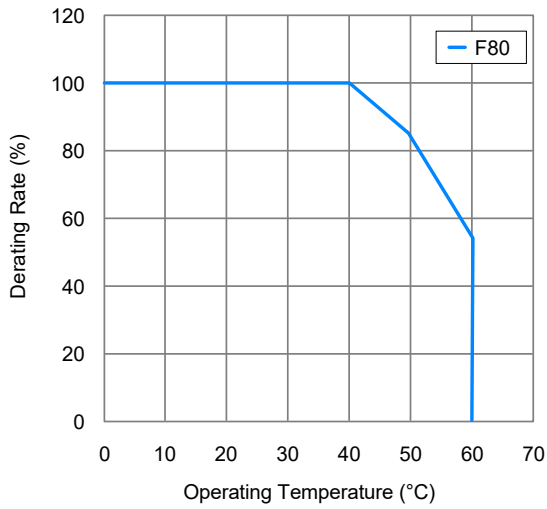
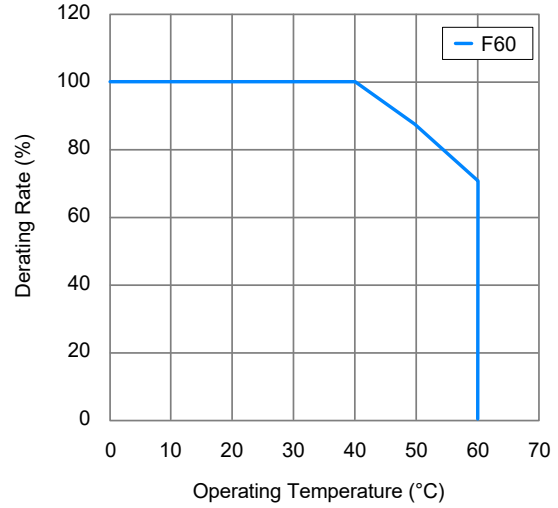
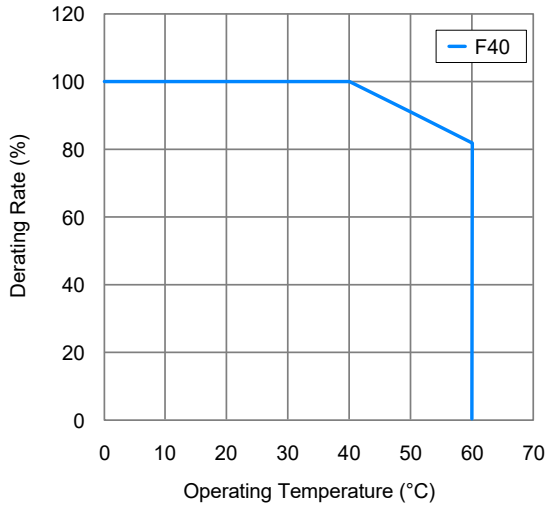

Dimensions of Motors with Frame Size of 80 mm or Below

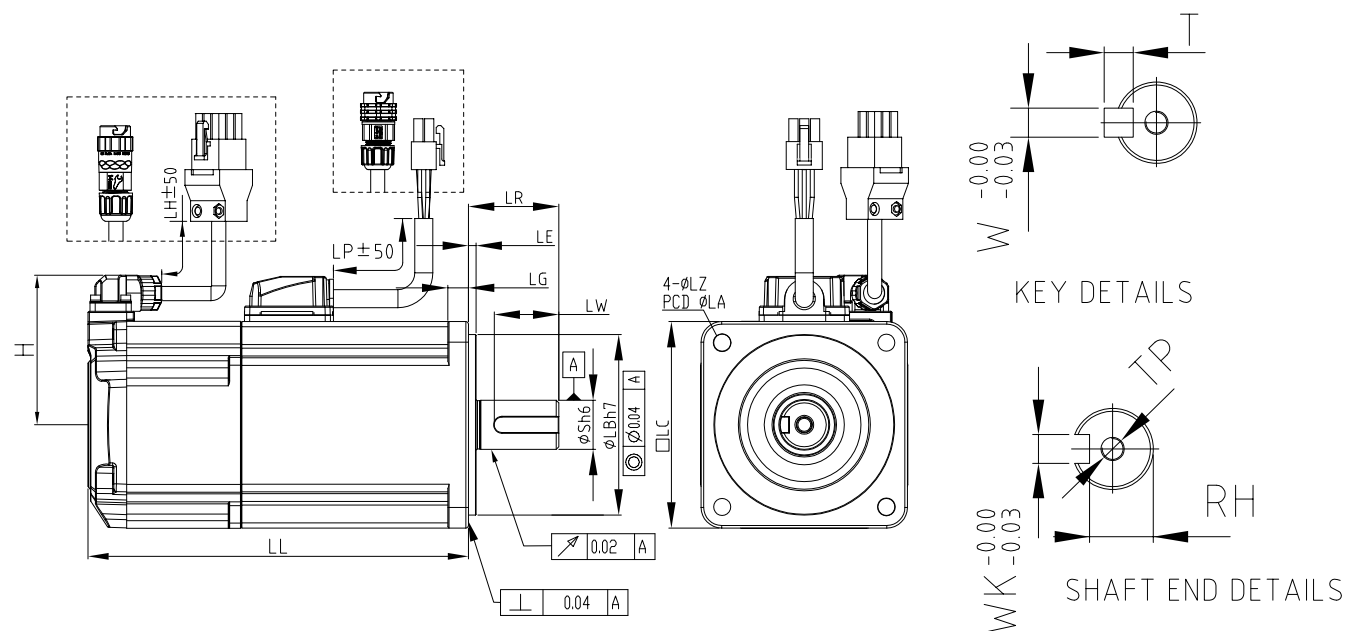

Model	C 2 0401 3 4 5	C 2 0602 3 4 5	C 2 0604 3 4 5	C 2 0804 3 4 5	C 2 0807 3 4 5
LC	40	60	60	80	80
LZ	4.5	5.5	5.5	6.6	6.6
LA	46	70	70	90	90
S	8($\begin{smallmatrix} +0 \\ -0.009 \end{smallmatrix}$)	14($\begin{smallmatrix} +0 \\ -0.011 \end{smallmatrix}$)	14($\begin{smallmatrix} +0 \\ -0.011 \end{smallmatrix}$)	14($\begin{smallmatrix} +0 \\ -0.011 \end{smallmatrix}$)	19($\begin{smallmatrix} +0 \\ -0.013 \end{smallmatrix}$)
LB	30($\begin{smallmatrix} +0 \\ -0.021 \end{smallmatrix}$)	50($\begin{smallmatrix} +0 \\ -0.025 \end{smallmatrix}$)	50($\begin{smallmatrix} +0 \\ -0.025 \end{smallmatrix}$)	70($\begin{smallmatrix} +0 \\ -0.030 \end{smallmatrix}$)	70($\begin{smallmatrix} +0 \\ -0.030 \end{smallmatrix}$)
LL (w/o brake)	77.6	72.5	91	86.7	105.2
LL (with brake)	111.7	109.4	127.9	126.3	144.8
LH	300	300	300	300	300
LP	300	300	300	300	300
H	40	48.5	48.5	58.5	58.5
LR	25	30	30	30	35
LE	2.5	3	3	3	3
LG	5	7.5	7.5	8	8
LW	16	20	20	20	25
RH	6.2	11	11	11	15.5
WK	3	5	5	5	6
W	3	5	5	5	6
T	3	5	5	5	6
TP	M3 Depth 8	M4 Depth 15	M4 Depth 15	M4 Depth 15	M6 Depth 20

Note:

- In the servo motor model name, [2] represents the encoder type, [2] represents the brake or keyway / oil seal type, [4] represents the shaft diameter and connector type, and [5] represents the special code.
- When [4] in the servo motor model name is J or K, the connector is an IP67 waterproof connector.

ECM-B3 Series Servo Motor Specifications

Dimensions of Motors with Frame Size of 130 to 180 mm

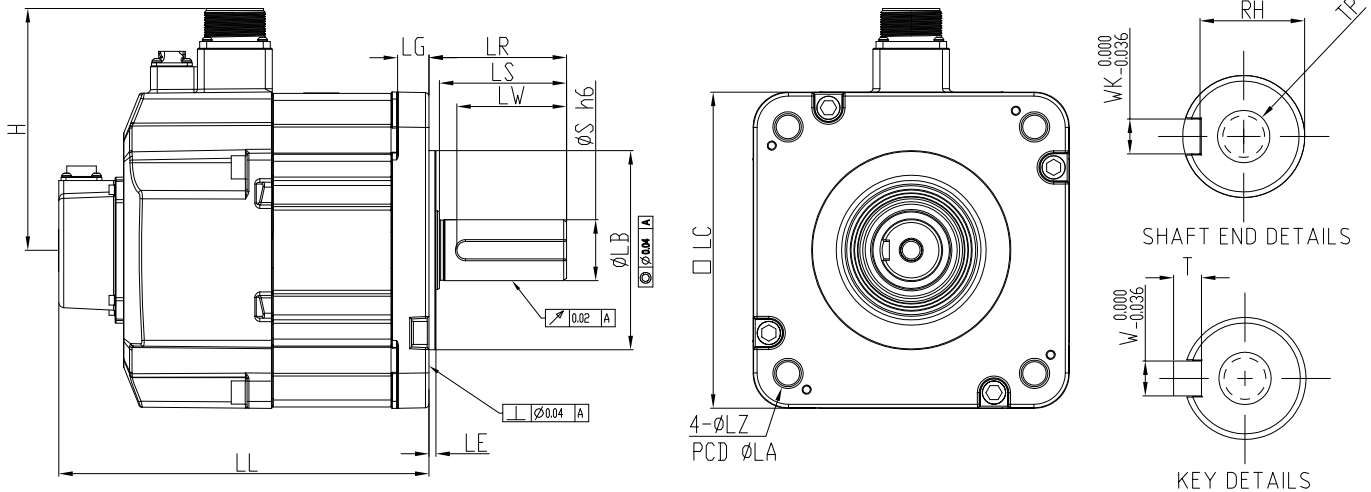



Model	E 2 1310 3 4 5	E 2 1315 3 4 5	E 2 1320 3 4 5	E 2 1820 3 4 5	F 2 1830 3 4 5
LC	130	130	130	180	180
LZ	9	9	9	13.5	13.5
LA	145	145	145	200	200
S	22(⁺⁰ / _{-0.013})	22(⁺⁰ / _{-0.013})	22(⁺⁰ / _{-0.013})	35(⁺⁰ / _{-0.016})	35(⁺⁰ / _{-0.016})
LB	110(⁺⁰ / _{-0.035})	110(⁺⁰ / _{-0.035})	110(⁺⁰ / _{-0.035})	114.3(⁺⁰ / _{-0.035})	114.3(⁺⁰ / _{-0.035})
LL (w/o brake)	127.9	139.9	151.9	137.5	160.5
LL (with brake)	168.5	180.5	192.5	189.5	212.5
H	115	115	115	139	139
LS	47	47	47	73	73
LR	55	55	55	79	79
LE	6	6	6	4	4
LG	12.5	12.5	12.5	18	18
LW	36	36	36	63	63
RH	18	18	18	30	30
WK	8	8	8	10	10
W	8	8	8	10	10
T	7	7	7	8	8
TP	M6 Depth 12	M6 Depth 12	M6 Depth 12	M12 Depth 25	M12 Depth 25

Note:
In the servo motor model name, [2] represents the encoder type, [3] represents the brake or keyway / oil seal type, [4] represents the shaft diameter and connector type, and [5] represents the special code.

ECM-A3 Series Servo Motor Specifications

Electrical Specifications

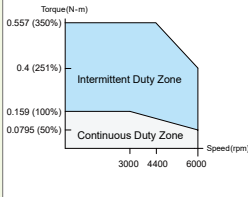
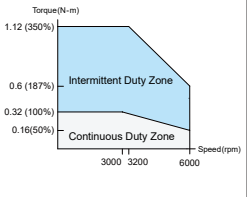
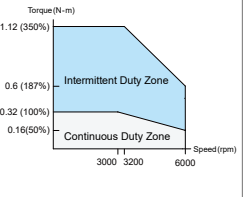
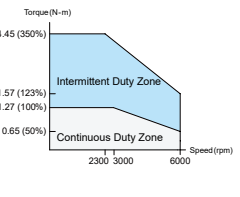
ECM-A3L Low Inertia Series Servo Motor

	ECM-A3L-C [2] 040F ^{*1}	ECM-A3L-C [2] 040I ^{*1}	ECM-A3L-C [2] 0602 ^{*1}	ECM-A3L-C [2] 0604 ^{*1}
Rated Power (kW)	0.05	0.1	0.2	0.4
Rated Torque (N-m) ^{*1}	0.159	0.32	0.64	1.27
Maximum Torque (N-m)	0.557	1.12	2.24	4.45
Rated Speed (rpm)	3000			
Maximum Speed (rpm)	6000			
Rated Current (Arms)	0.66	0.9	1.45	2.65
Max. Instantaneous Current (Arms)	2.82	3.88	6.2	10.1
Rated Power Rate (kW/s) ^{*5}	11 (9.9)	25.6 (24)	45.5 (34.1)	107.5 (89.6)
Rotor Inertia ($\times 10^{-4}$ kg.m ²) ^{*5}	0.0229 (0.0255)	0.04 (0.0426)	0.09 (0.12)	0.15 (0.18)
Mechanical Time Constant (ms) ^{*5}	1.28 (1.44)	0.838 (0.892)	0.64 (0.85)	0.41 (0.5)
Torque Constant -KT (N-m/A)	0.241	0.356	0.441	0.479
Voltage Constant -KE (mV/(rpm))	9.28	13.3	16.4	18
Armature Resistance (Ohm)	12.1	9.47	4.9	2.27
Armature Inductance (mH)	18.6	16.2	18.52	10.27
Electrical Time Constant (ms)	1.54	1.71	3.78	4.52
Brake Holding Torque [Nt-m (min)] ^{*2}	0.32	0.32	1.3	1.3
Brake Power Consumption (at 20°C)[W]	6.1	6.1	7.2	7.2
Brake Release Time [ms (Max.)]	20	20	20	20
Brake Pull-In Time [ms (Max.)]	35	35	50	50
Max. Radial Loading (N)	78	78	245	245
Max. Axial Loading (N)	54	54	74	74
Weight (kg) ^{*5}	0.38 (0.68)	0.5 (0.8)	1.1 (1.6)	1.4 (1.9)
Derating (%) (with oil seal)	20	10	10	5
Torque Feature (T-N Curve)				
Insulation Class	Class A (UL), Class B (CE)			
Insulation Resistance	> 100 MΩ, DC 500V			
Insulation Strength	1.8 kVac, 1 sec			
Vibration Level (μm)	V15			
Operating Temperature	0°C ~ 40°C*3			
Storage Temperature	-10°C ~ 80°C*3			
Storage & Operation Humidity	20 ~ 90%RH (non-condensing)			
Vibration Capacity	2.5 G			
IP Rating	IP67 (when using waterproof connections and when an oil seal is fitted to the rotating shaft (for an oil seal model))			
Certifications				

Note:

- In the servo motor model name, [1] represents the motor inertia and [2] represents the encoder type.
- The rated torque is the continuous permissible torque between 0 to 40°C operating temperature which is suitable for the servo motor mounted with the following heat sink dimensions.
F40, F60, F80: 250 mm x 250 mm x 6 mm
Material: aluminum
- () = motor with brake
- The built-in servo motor brake is only for keeping the object in a stopped state.
Do not use it for deceleration or as a dynamic brake

5. Please follow the max. tolerant loading of the motor shaft end listed below during operation

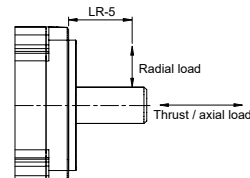

ECM-A3 Series Servo Motor Specifications

Electrical Specifications

ECM-A3L Low Inertia Series Servo Motor / ECM-A3H High Inertia Series Servo Motor

	ECM-A3L-C [2] 0804 ^{†1}	ECM-A3L-C [2] 0807 ^{†1}	ECM-A3H-C [2] 040F ^{†1}	ECM-A3H-C [2] 0401 ^{†1}
Rated Power (kW)	0.4	0.75	0.05	0.1
Rated Torque (N-m) ^{†1}	1.27	2.39	0.159	0.32
Maximum Torque (N-m)	4.44	8.36	0.557	1.12
Rated Speed (rpm)	3000			
Maximum Speed (rpm)	6000			
Rated Current (Arms)	2.6	5.1	0.64	0.9
Max. Instantaneous Current (Arms)	10.6	20.6	2.59	3.64
Rated Power Rate (kW/s) ^{†5}	45.8 (39.5)	102.2 (93)	5.56 (4.89)	13.6 (12.5)
Rotor Inertia ($\times 10^{-4}$ kg.m ²) ^{†5}	0.352 (0.408)	0.559 (0.614)	0.0455 (0.0517)	0.0754 (0.0816)
Mechanical Time Constant (ms) ^{†5}	0.68 (0.78)	0.44 (0.48)	2.52 (2.86)	1.43 (1.55)
Torque Constant -KT (N-m/A)	0.488	0.469	0.248	0.356
Voltage Constant -KE (mV/(rpm))	17.9	17	9.54	12.9
Armature Resistance (Ohm)	1.6	0.6	12.5	8.34
Armature Inductance (mH)	10.6	4.6	13.34	11
Electrical Time Constant (ms)	6.63	7.67	1.07	1.32
Brake Holding Torque [N-t-m (min)] ^{†4}	2.5	2.5	0.32	0.32
Brake Power Consumption (at 20°C)[W]	8	8	6.1	6.1
Brake Release Time [ms (Max.)]	20	20	20	20
Brake Pull-In Time [ms (Max.)]	60	60	35	35
Max. Radial Loading (N)	392	392	78	78
Max. Axial Loading (N)	147	147	54	54
Weight (kg) ^{†5}	2.05 (2.85)	2.8 (3.6)	0.38 (0.68)	0.5 (0.8)
Derating (%) (with oil seal)	5	5	20	10
Torque Feature (T-N Curve)				
Insulation Class	Class A (UL), Class B (CE)			
Insulation Resistance	100 MΩ · DC 500 V 以上			
Insulation Strength	> 100 MΩ, DC 500V			
Vibration Level (μm)	V15			
Operating Temperature	0°C ~ 40°C* ³			
Storage Temperature	-10°C ~ 80°C* ³			
Storage & Operation Humidity	20 ~ 90%RH (non-condensing)			
Vibration Capacity	2.5 G			
IP Rating	IP67 (when using waterproof connections and when an oil seal is fitted to the rotating shaft (for an oil seal model))			
Certifications				



Note:

- In the servo motor model name, [] represents the motor inertia and [2] represents the encoder type.
- The rated torque is the continuous permissible torque between 0 to 40°C operating temperature which is suitable for the servo motor mounted with the following heat sink dimensions.
F40, F60, F80: 250 mm x 250 mm x 6 mm
Material: aluminum
- () = motor with brake
- The built-in servo motor brake is only for keeping the object in a stopped state.
Do not use it for deceleration or as a dynamic brake

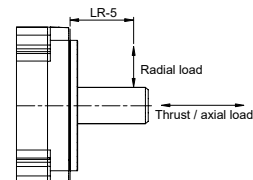
- Please follow the max. tolerating loading of the motor shaft end listed below during operation

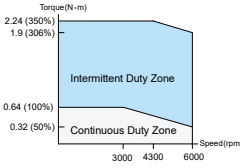
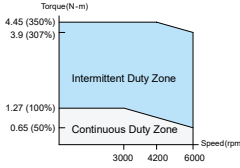
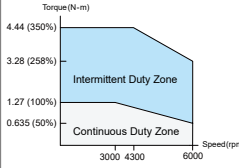
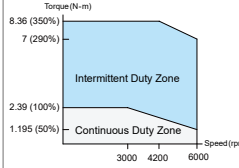

ECM-A3H High Inertia Series Servo Motor

	ECM-A3H-C [2] 0602 ¹	ECM-A3H-C [2] 0604 ¹	ECM-A3H-C [2] 0804 ¹	ECM-A3H-C [2] 0807 ¹
Rated Power (kW)	0.2	0.4	0.4	0.75
Rated Torque (N-m) ¹	0.64	1.27	1.27	2.39
Maximum Torque (N-m)	2.24	4.45	4.44	8.36
Rated Speed (rpm)	3000			
Maximum Speed (rpm)	6000			
Rated Current (Arms)	1.45	2.65	2.6	4.61
Max. Instantaneous Current (Arms)	5.3	9.8	9.32	16.4
Rated Power Rate (kW/s) ⁵	16.4 (14.6)	35.8 (33.6)	17.5 (15.07)	37.8 (34.41)
Rotor Inertia ($\times 10^{-4}$ kg.m ²) ⁵	0.25 (0.28)	0.45 (0.48)	0.92 (1.07)	1.51 (1.66)
Mechanical Time Constant (ms) ⁵	1.38 (1.54)	0.96 (1.02)	1.32 (1.54)	0.93 (1.02)
Torque Constant -KT (N-m/A)	0.441	0.479	0.49	0.52
Voltage Constant -KE (mV/(rpm))	16.4	17.2	17.9	18.7
Armature Resistance (Ohm)	3.8	1.68	1.19	0.57
Armature Inductance (mH)	8.15	4.03	4.2	2.2
Electrical Time Constant (ms)	2.14	2.40	3.53	3.86
Brake Holding Torque [Nt-m (min)] ⁷²	1.3	1.3	2.5	2.5
Brake Power Consumption (at 20°C)[W]	7.2	7.2	8	8
Brake Release Time [ms (Max.)]	20	20	20	20
Brake Pull-In Time [ms (Max.)]	50	50	60	60
Max. Radial Loading (N)	245	245	392	392
Max. Axial Loading (N)	74	74	147	147
Weight (kg) ⁵	1.1 (1.6)	1.4 (1.9)	2.05 (2.85)	2.8 (3.6)
Derating (%) (with oil seal)	10	5	5	5
Torque Feature (T-N Curve)				
Insulation Class	Class A (UL), Class B (CE)			
Insulation Resistance	100 MΩ · DC 500 V 以上			
Insulation Strength	> 100 MΩ, DC 500V			
Vibration Level (μm)	V15			
Operating Temperature	0°C ~ 40°C*3			
Storage Temperature	-10°C ~ 80°C*3			
Storage & Operation Humidity	20 ~ 90%RH (non-condensing)			
Vibration Capacity	2.5 G			
IP Rating	IP67 (when using waterproof connections and when an oil seal is fitted to the rotating shaft (for an oil seal model))			
Certifications				

Note:

- In the servo motor model name, [1] represents the motor inertia and [2] represents the encoder type.
- The rated torque is the continuous permissible torque between 0 to 40°C operating temperature which is suitable for the servo motor mounted with the following heat sink dimensions.
F40, F60, F80: 250 mm x 250 mm x 6 mm
Material: aluminum
- () = motor with brake
- The built-in servo motor brake is only for keeping the object in a stopped state.
Do not use it for deceleration or as a dynamic brake

5. Please follow the max. tolerant loading of the motor shaft end listed below during operation

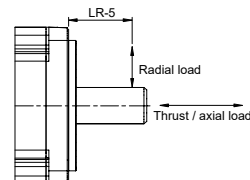

ECM-A3 Series Servo Motor Specifications

Dimensions of Motors with Frame Size of 80 mm and Below

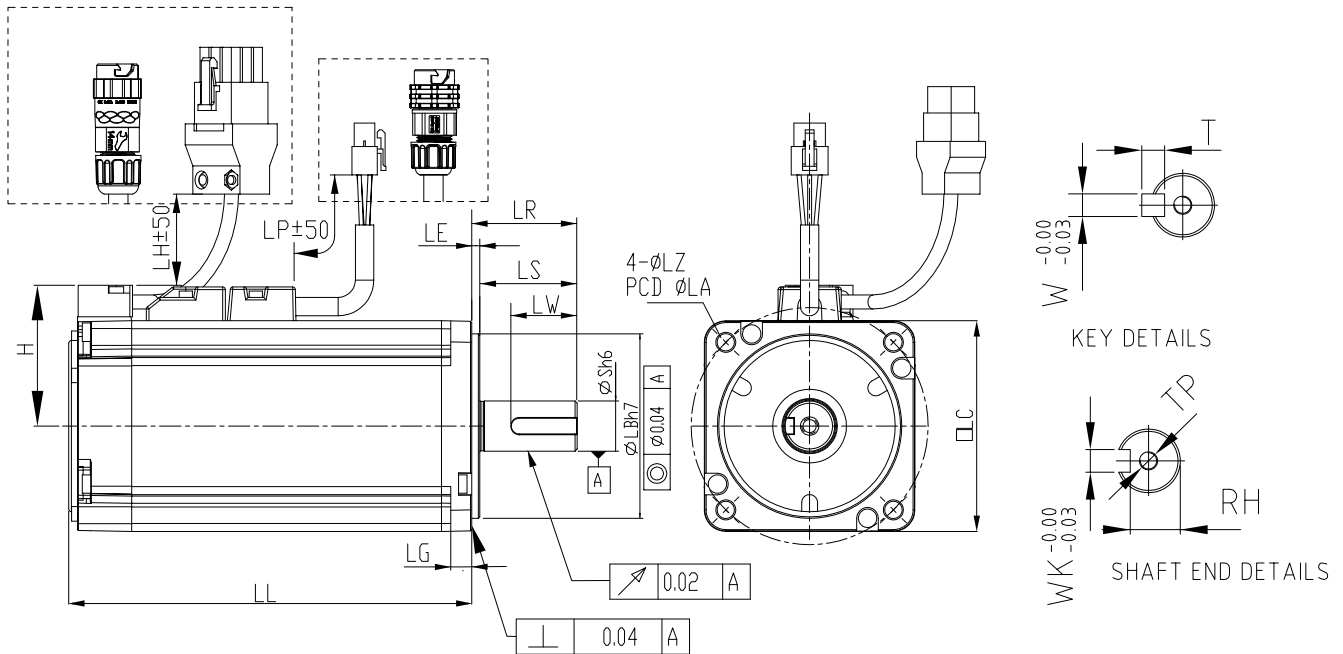

Model	C 2 040F 3 4 5	C 2 0401 3 4 5	C 2 0602 3 4 5	C 2 0604 3 4 5	C 2 0804 3 4 5	C 2 0807 3 4 5
LC	40	40	60	60	80	80
LZ	4.5	4.5	5.5	5.5	6.6	6.6
LA	46	46	70	70	90	90
S	8 ^(+0/-0.009)	8 ^(+0/0.009)	14 ^(+0/-0.011)	14 ^(+0/-0.011)	14 ^(+0/-0.011)	19 ^(+0/-0.013)
LB	30 ^(+0/-0.021)	30 ^(+0/-0.021)	50 ^(+0/-0.025)	50 ^(+0/-0.025)	70 ^(+0/-0.030)	70 ^(+0/-0.030)
LL (w/o brake)	70.6	85.3	84	106	93.7	115.8
LL (with brake)	105.4	120.1	117.6	139.7	131.2	153.2
LH	300	300	300	300	300	300
LP	300	300	300	300	300	300
H	34	34	43.5	43.5	54.5	54.5
LS	21.5	21.5	27	27	27	37
LR	25	25	30	30	30	40
LE	2.5	2.5	3	3	3	3
LG	5	5	7.5	7.5	8	8
LW	16	16	20	20	20	25
RH	6.2	6.2	11	11	11	15.5
WK	3	3	5	5	5	6
W	3	3	5	5	5	6
T	3	3	5	5	5	6
TP	M3 Depth 6	M3 Depth 6	M4 Depth 8	M4 Depth 8	M4 Depth 8	M6 Depth 10

Note:

- In the servo motor model name, [2] represents the encoder type, [3] represents the brake or keyway / oil seal type, [4] represents the shaft diameter and connector type, and [5] represents the special code.
- When the special code of the C 2 0807 [3] [4] [5] model is Z, then its LS = 32 and LR = 35.
- When the [4] in the motor model name is J or K, the connector is an IP67 waterproof connector.

Ordering Information

Accessories

Power Connectors

ASDBCAPW0000
(for F80 and below)

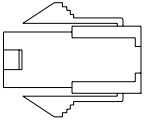

ASDBCAPW0100
(for F80 and below with brake)

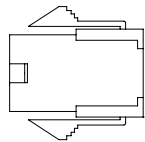

ACS3-CNPW1A00
(for F80 and below)
IP67 waterproof connector

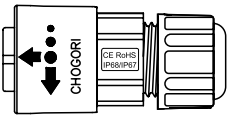

ACS3-CNPW2A00
(for F80 and below with brake)
IP67 waterproof connector

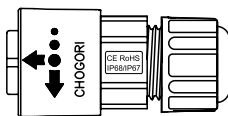

ACS3-CNPW5200
(for F100 ~ F130)
Mil-Spec: MIL 3106A18-10S

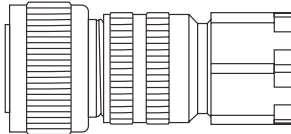

ACS3-CNPW5300
(for F180)
Mil-Spec: MIL 3106A22-22S

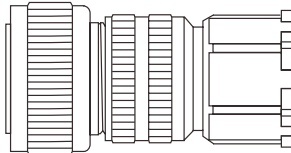

ACS3-CNPW6300
(F100 ~ F180 with brake)
Mil-Spec: CMV1-SP2S

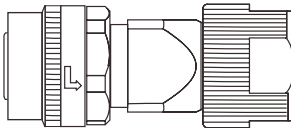

ACS3-CNPW5C00
(for F100 ~ F130 models)
Mil-Spec: MIL 3108A18-10S

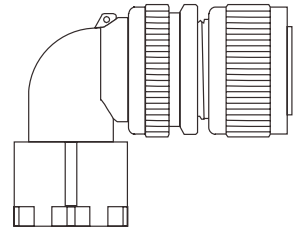

ACS3-CNPW5D00
(for F180)
Mil-Spec: MIL 3108A22-22S

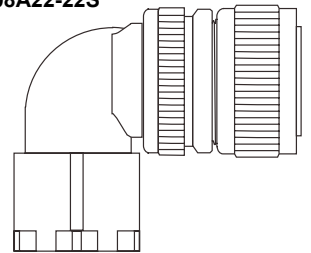

ACS3-CNPW6D00
(F100 ~ F180 with brake)
Mil-Spec: CMV1-AP2S

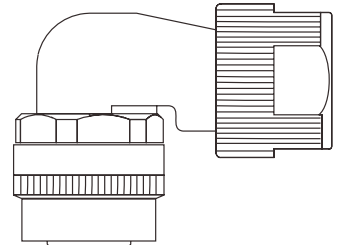

Power Cables

ACS3-CAPW3103, ACS3-CAPW3105, ACS3-CAPW3110, ACS3-CAPW3120,
ACS3-CAPF3103, ACS3-CAPF3105, ACS3-CAPF3110, ACS3-CAPF3120
(for F80 and below)

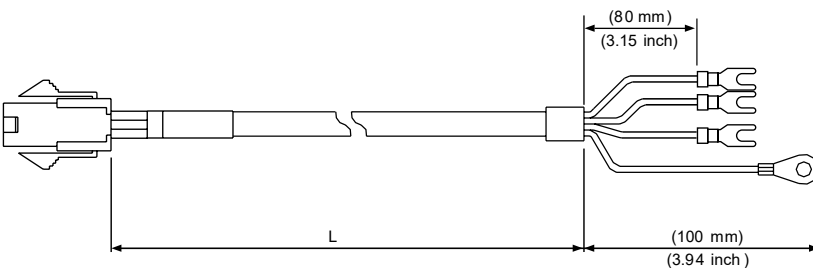

Cable	Part No.	L	
		mm	inch
Standard	ACS3-CAPW3103	3000 ± 50	118 ± 2
	ACS3-CAPW3105	5000 ± 50	197 ± 2
	ACS3-CAPW3110	10000 ± 100	394 ± 4
	ACS3-CAPW3120	20000 ± 100	788 ± 4
Torsion-Resistant	ACS3-CAPF3103	3000 ± 50	118 ± 2
	ACS3-CAPF3105	5000 ± 50	197 ± 2
	ACS3-CAPF3110	10000 ± 100	394 ± 4
	ACS3-CAPF3120	20000 ± 100	788 ± 4

Power Cables

ACS3-CAPW4103, ACS3-CAPW4105, ACS3-CAPW4110, ACS3-CAPW4120, ACS3-CAPF4103, ACS3-CAPF4105, ACS3-CAPF4110, ACS3-CAPF4120
(for F80 and below with brake)

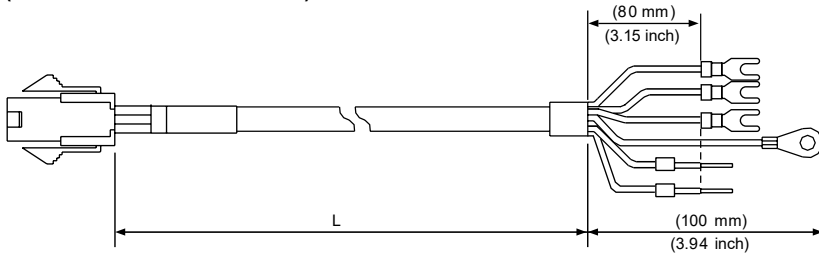

Cable	Part No.	L	
		mm	inch
Standard	ACS3-CAPW4103	3000 ± 50	118 ± 2
	ACS3-CAPW4105	5000 ± 50	197 ± 2
	ACS3-CAPW4110	10000 ± 100	394 ± 4
	ACS3-CAPW4120	20000 ± 100	788 ± 4
Torsion-Resistant	ACS3-CAPF4103	3000 ± 50	118 ± 2
	ACS3-CAPF4105	5000 ± 50	197 ± 2
	ACS3-CAPF4110	10000 ± 100	394 ± 4
	ACS3-CAPF4120	20000 ± 100	788 ± 4

ACS3-CAPW3A03, ACS3-CAPW3A05, ACS3-CAPW3A10, ACS3-CAPW3A20, ACS3-CAPF3A03, ACS3-CAPF3A05, ACS3-CAPF3A10, ACS3-CAPF3A20
(for F80 and below with IP67 waterproof connector)

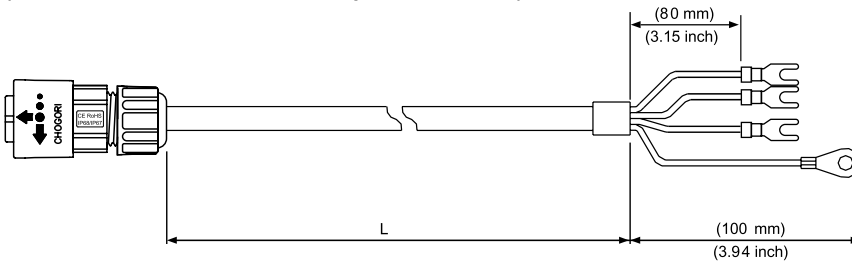

Cable	Part No.	L	
		mm	inch
Standard	ACS3-CAPW3A03	3000 ± 50	118 ± 2
	ACS3-CAPW3A05	5000 ± 50	197 ± 2
	ACS3-CAPW3A10	10000 ± 100	394 ± 4
	ACS3-CAPW3A20	20000 ± 100	788 ± 4
Torsion-Resistant	ACS3-CAPF3A03	3000 ± 50	118 ± 2
	ACS3-CAPF3A05	5000 ± 50	197 ± 2
	ACS3-CAPF3A10	10000 ± 100	394 ± 4
	ACS3-CAPF3A20	20000 ± 100	788 ± 4

ACS3-CAPW4A03, ACS3-CAPW4A05, ACS3-CAPW4A10, ACS3-CAPW4A20, ACS3-CAPF4A03, ACS3-CAPF4A05, ACS3-CAPF4A10, ACS3-CAPF4A20
(for F80 and below with brake and IP67 waterproof connector)

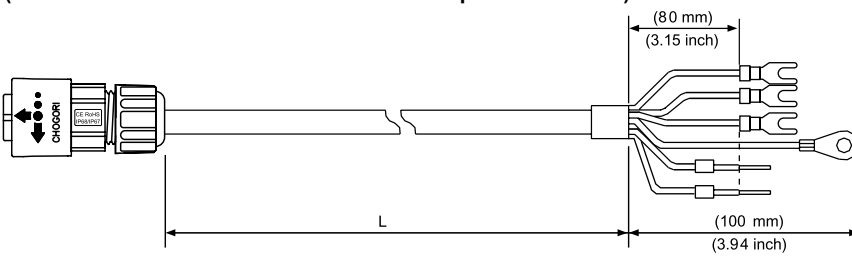

Cable	Part No.	L	
		mm	inch
Standard	ACS3-CAPW4A03	3000 ± 50	118 ± 2
	ACS3-CAPW4A05	5000 ± 50	197 ± 2
	ACS3-CAPW4A10	10000 ± 100	394 ± 4
	ACS3-CAPW4A20	20000 ± 100	788 ± 4
Torsion-Resistant	ACS3-CAPF4A03	3000 ± 50	118 ± 2
	ACS3-CAPF4A05	5000 ± 50	197 ± 2
	ACS3-CAPF4A10	10000 ± 100	394 ± 4
	ACS3-CAPF4A20	20000 ± 100	788 ± 4

ACS3-CAPW3203, ACS3-CAPW3205, ACS3-CAPW3210, ACS3-CAPW3220, ACS3-CAPF3203, ACS3-CAPF3205, ACS3-CAPF3210, ACS3-CAPF3220
(for F100 - F130)

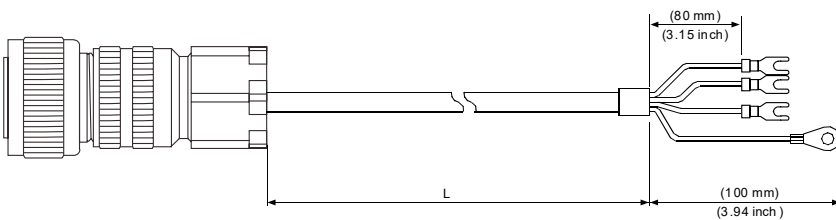

Cable	Part No.	L	
		mm	inch
Standard	ACS3-CAPW3203	3000 ± 50	118 ± 2
	ACS3-CAPW3205	5000 ± 50	197 ± 2
	ACS3-CAPW3210	10000 ± 100	394 ± 4
	ACS3-CAPW3220	20000 ± 100	788 ± 4
Torsion-Resistant	ACS3-CAPF3203	3000 ± 50	118 ± 2
	ACS3-CAPF3205	5000 ± 50	197 ± 2
	ACS3-CAPF3210	10000 ± 100	394 ± 4
	ACS3-CAPF3220	20000 ± 100	788 ± 4

Ordering Information

Accessories

Power Cables

ACS3-CAPW4203, ACS3-CAPW4205, ACS3-CAPW4210, ACS3-CAPW4220,
ACS3-CAPF4203, ACS3-CAPF4205, ACS3-CAPF4210, ACS3-CAPF4220
(for F100 - F130 with brake)

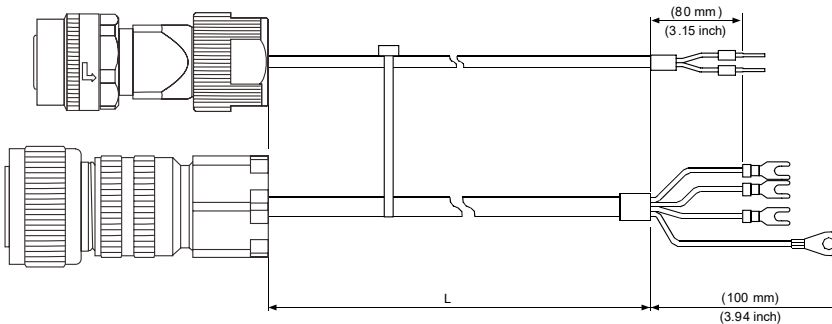

Cable	Part No.	L	
		mm	inch
Standard	ACS3-CAPW4203	3000 ± 50	118 ± 2
	ACS3-CAPW4205	5000 ± 50	197 ± 2
	ACS3-CAPW4210	10000 ± 100	394 ± 4
	ACS3-CAPW4220	20000 ± 100	788 ± 4
Torsion-Resistant	ACS3-CAPF4203	3000 ± 50	118 ± 2
	ACS3-CAPF4205	5000 ± 50	197 ± 2
	ACS3-CAPF4210	10000 ± 100	394 ± 4
	ACS3-CAPF4220	20000 ± 100	788 ± 4

ACS3-CAPW3403, ACS3-CAPW3405, ACS3-CAPW3410, ACS3-CAPW3420,
ACS3-CAPF3403, ACS3-CAPF3405, ACS3-CAPF3410, ACS3-CAPF3420
(for F180)

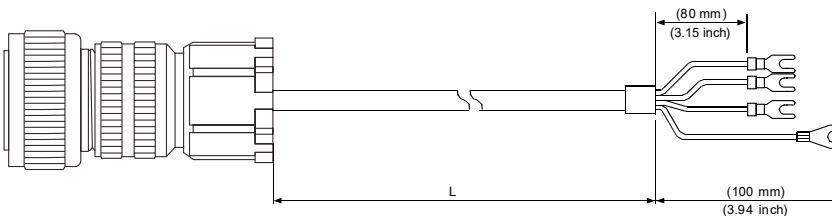

Cable	Part No.	L	
		mm	inch
Standard	ACS3-CAPW3403	3000 ± 50	118 ± 2
	ACS3-CAPW3405	5000 ± 50	197 ± 2
	ACS3-CAPW3410	10000 ± 100	394 ± 4
	ACS3-CAPW3420	20000 ± 100	788 ± 4
Torsion-Resistant	ACS3-CAPF3403	3000 ± 50	118 ± 2
	ACS3-CAPF3405	5000 ± 50	197 ± 2
	ACS3-CAPF3410	10000 ± 100	394 ± 4
	ACS3-CAPF3420	20000 ± 100	788 ± 4

ACS3-CAPW4403, ACS3-CAPW4405, ACS3-CAPW4410, ACS3-CAPW4420,
ACS3-CAPF4403, ACS3-CAPF4405, ACS3-CAPF4410, ACS3-CAPF4420
(for F180 with brake)

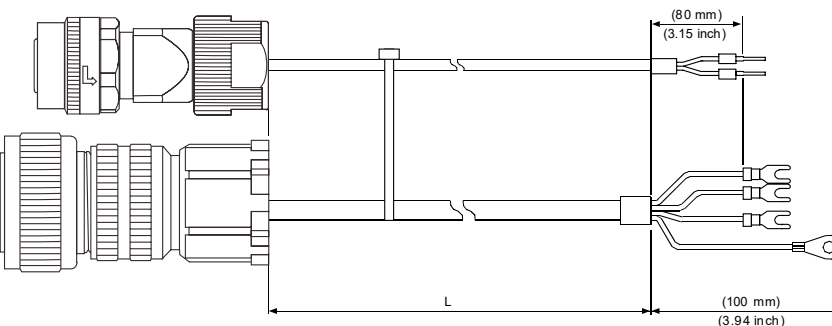

Cable	Part No.	L	
		mm	inch
Standard	ACS3-CAPW4403	3000 ± 50	118 ± 2
	ACS3-CAPW4405	5000 ± 50	197 ± 2
	ACS3-CAPW4410	10000 ± 100	394 ± 4
	ACS3-CAPW4420	20000 ± 100	788 ± 4
Torsion-Resistant	ACS3-CAPF4403	3000 ± 50	118 ± 2
	ACS3-CAPF4405	5000 ± 50	197 ± 2
	ACS3-CAPF4410	10000 ± 100	394 ± 4
	ACS3-CAPF4420	20000 ± 100	788 ± 4

Encoder Connectors

ACS3-CNENC200
(connecting to drive)

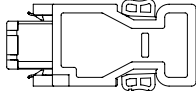

ACS3-CNEN2700
(for F100 ~ F180)
Mil-Spec: CMV1-SP10S

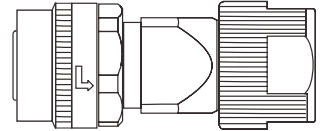

ACS3-CNEN1000
(for F80 and below)

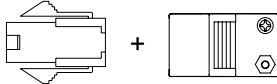

ACS3-CNEN2C00
(for F100 ~ F180)
Mil-Spec: CMV1-AP10S

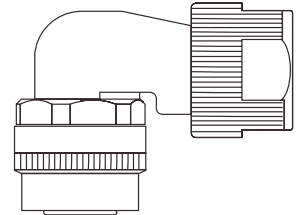

ACS3-CNEN2A00
(for F80 and below)
IP67 waterproof connector

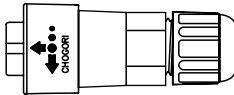

Encoder Cables (Incremental Type)

ACS3-CAEN1003, ACS3-CAEN1005, ACS3-CAEN1010, ACS3-CAEN1020,
ACS3-CAEF1003, ACS3-CAEF1005, ACS3-CAEF1010, ACS3-CAEF1020
(for F80 and below)

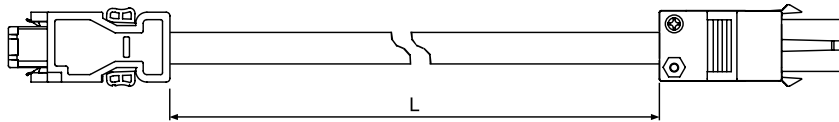

Cable	Part No.	L	
		mm	inch
Standard	ACS3-CAEN1003	3000 ± 50	118 ± 2
	ACS3-CAEN1005	5000 ± 50	197 ± 2
	ACS3-CAEN1010	10000 ± 100	394 ± 4
	ACS3-CAEN1020	20000 ± 100	788 ± 4
Torsion-Resistant	ACS3-CAEF1003	3000 ± 50	118 ± 2
	ACS3-CAEF1005	5000 ± 50	197 ± 2
	ACS3-CAEF1010	10000 ± 100	394 ± 4
	ACS3-CAEF1020	20000 ± 100	788 ± 4

ACS3-CAEN2A03, ACS3-CAEN2A05, ACS3-CAEN2A10, ACS3-CAEN2A20,
ACS3-CAEF2A03, ACS3-CAEF2A05, ACS3-CAEF2A10, ACS3-CAEF2A20
(for F80 and below with IP67 waterproof connector)

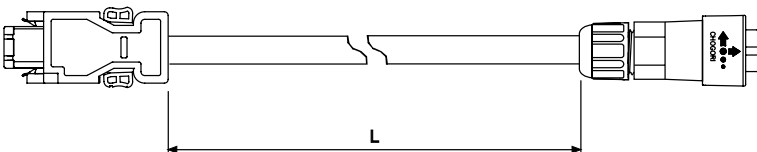

Cable	Part No.	L	
		mm	inch
Standard	ACS3-CAEN2A03	3000 ± 50	118 ± 2
	ACS3-CAEN2A05	5000 ± 50	197 ± 2
	ACS3-CAEN2A10	10000 ± 100	394 ± 4
	ACS3-CAEN2A20	20000 ± 100	788 ± 4
Torsion-Resistant	ACS3-CAEF2A03	3000 ± 50	118 ± 2
	ACS3-CAEF2A05	5000 ± 50	197 ± 2
	ACS3-CAEF2A10	10000 ± 100	394 ± 4
	ACS3-CAEF2A20	20000 ± 100	788 ± 4

Ordering Information

Accessories

Encoder Cables (Incremental Type)

ACS3-CAEN2703, ACS3-CAEN2705, ACS3-CAEN2710, ACS3-CAEN2720,
ACS3-CAEF2703, ACS3-CAEF2705, ACS3-CAEF2710, ACS3-CAEF2720
(for F100 - F180)

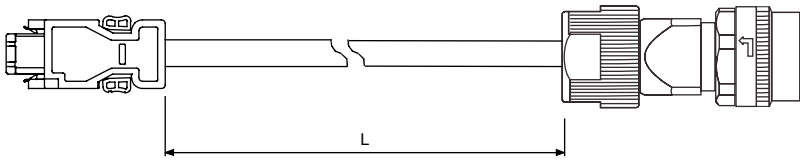

Cable	Part No.	L	
		mm	inch
Standard	ACS3-CAEN2703	3000 ± 50	118 ± 2
	ACS3-CAEN2705	5000 ± 50	197 ± 2
	ACS3-CAEN2710	10000 ± 100	394 ± 4
	ACS3-CAEN2720	20000 ± 100	788 ± 4
Torsion-Resistant	ACS3-CAEF2703	3000 ± 50	118 ± 2
	ACS3-CAEF2705	5000 ± 50	197 ± 2
	ACS3-CAEF2710	10000 ± 100	394 ± 4
	ACS3-CAEF2720	20000 ± 100	788 ± 4

Encoder Cables (Absolute Type)

ACS3-CAEA1003, ACS3-CAEA1005, ACS3-CAEA1010, ACS3-CAEA1020,
ACS3-CAEB1003, ACS3-CAEB1005, ACS3-CAEB1010, ACS3-CAEB1020
(for F80 and below)

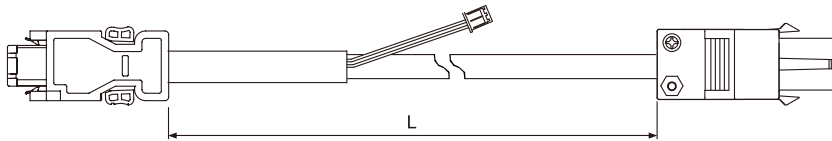

Cable	Part No.	L	
		mm	inch
Standard	ACS3-CAEA1003	3000 ± 50	118 ± 2
	ACS3-CAEA1005	5000 ± 50	197 ± 2
	ACS3-CAEA1010	10000 ± 100	394 ± 4
	ACS3-CAEA1020	20000 ± 100	788 ± 4
Torsion-Resistant	ACS3-CAEB1003	3000 ± 50	118 ± 2
	ACS3-CAEB1005	5000 ± 50	197 ± 2
	ACS3-CAEB1010	10000 ± 100	394 ± 4
	ACS3-CAEB1020	20000 ± 100	788 ± 4

ACS3-CAEA2A03, ACS3-CAEA2A05, ACS3-CAEA2A10, ACS3-CAEA2A20,
ACS3-CAEB2A03, ACS3-CAEB2A05, ACS3-CAEB2A10, ACS3-CAEB2A20
(for F80 and below with IP67 waterproof connector)

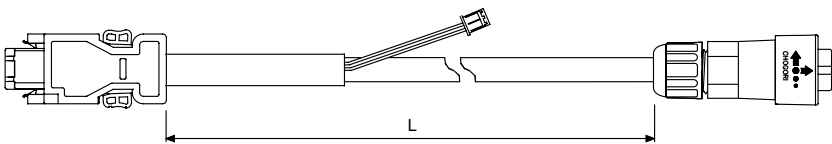

Cable	Part No.	L	
		mm	inch
Standard	ACS3-CAEA2A03	3000 ± 50	118 ± 2
	ACS3-CAEA2A05	5000 ± 50	197 ± 2
	ACS3-CAEA2A10	10000 ± 100	394 ± 4
	ACS3-CAEA2A20	20000 ± 100	788 ± 4
Torsion-Resistant	ACS3-CAEB2A03	3000 ± 50	118 ± 2
	ACS3-CAEB2A05	5000 ± 50	197 ± 2
	ACS3-CAEB2A10	10000 ± 100	394 ± 4
	ACS3-CAEB2A20	20000 ± 100	788 ± 4

ACS3-CAEA2703, ACS3-CAEA2705, ACS3-CAEA2710, ACS3-CAEA2720,
ACS3-CAEB2703, ACS3-CAEB2705, ACS3-CAEB2710, ACS3-CAEB2720
(for F100 ~ F180)

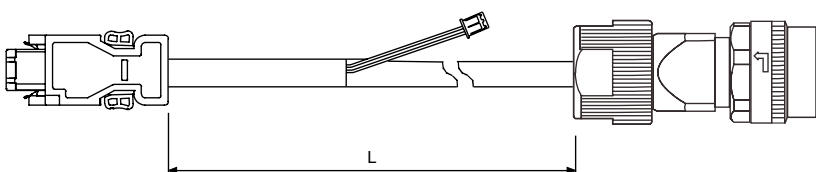

Cable	Part No.	L	
		mm	inch
Standard	ACS3-CAEA2703	3000 ± 50	118 ± 2
	ACS3-CAEA2705	5000 ± 50	197 ± 2
	ACS3-CAEA2710	10000 ± 100	394 ± 4
	ACS3-CAEA2720	20000 ± 100	788 ± 4
Torsion-Resistant	ACS3-CAEB2703	3000 ± 50	118 ± 2
	ACS3-CAEB2705	5000 ± 50	197 ± 2
	ACS3-CAEB2710	10000 ± 100	394 ± 4
	ACS3-CAEB2720	20000 ± 100	788 ± 4

Absolute Battery Box

**Single Battery Box
ASD-MDBT0100**

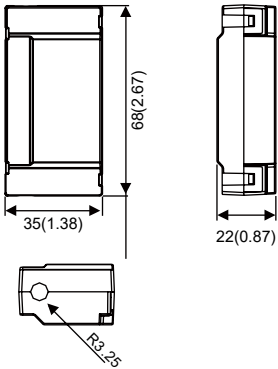

**Double Battery Box
ASD-MDBT0200**

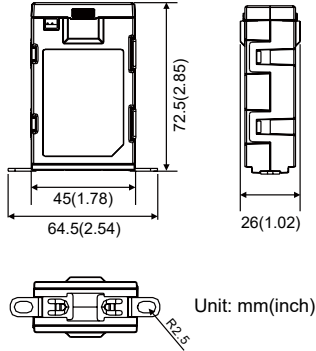

Unit: mm(inch)

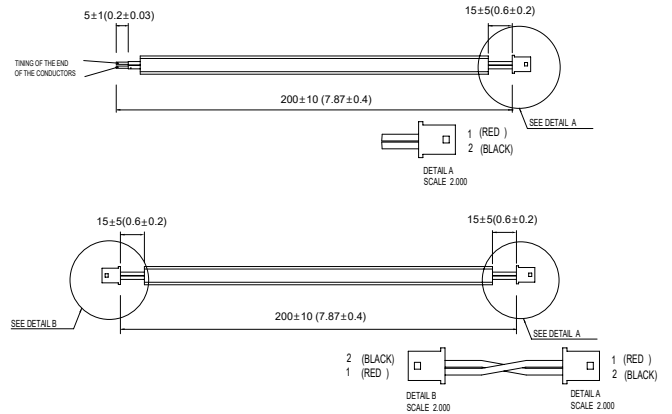

Note: Contact Delta Global Service team if ordering battery box cord only.

Terminal Block Module

ACS3-MDTB4400 (for B3-L)

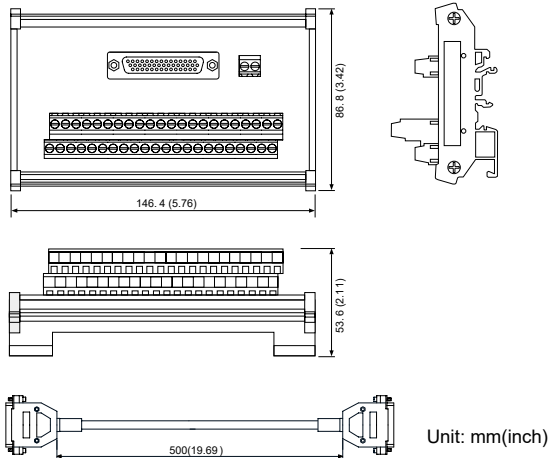

Unit: mm(inch)

ACS3-MDTD2600 (for B3-M, F, and E)

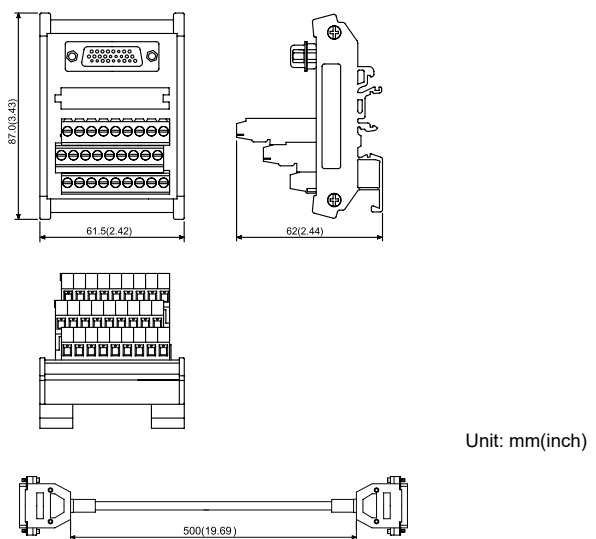

Unit: mm(inch)

CN3 CANopen Communication Cable

UC-CMC030-01A 、 UC-CMC050-01A

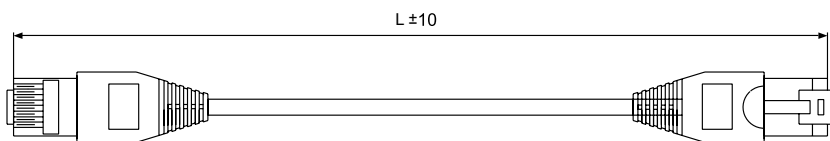

Item	Part No.	L	
		mm	inch
1	UC-CMC030-01A	3000 ± 10	11 ± 0.4
2	UC-CMC050-01A	5000 ± 10	19 ± 0.4

Ordering Information

Accessories

CN1 Connectors

ACS3-CNTB0400 (for B3-L)

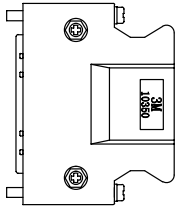

ACS3-CNTB0500 (for B3-M, F, and E)

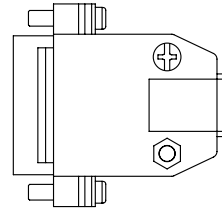

CN1 Quick Connector

ACS3-IFSC4444 (for B3-L)

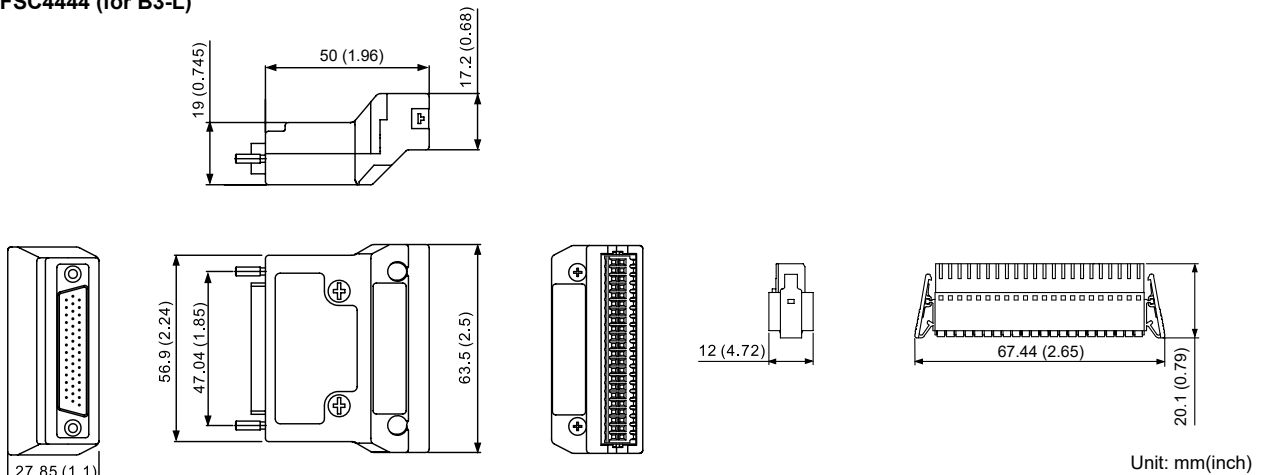

CN3 CANopen Distribution Box

TAP-CN03

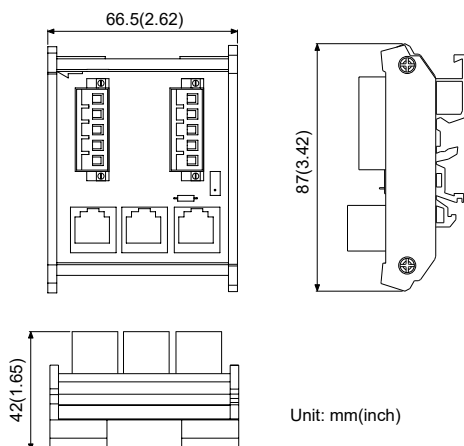

CN3 RS-485 Tap

ACS3-CNADC3RC

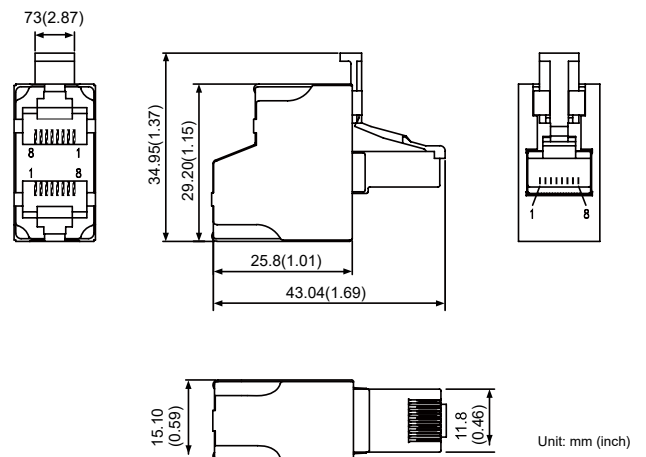

B3/B2 Conversion Cables

B3/B2 CN1 conversion cable (for B3-L)
ACS3-CABDC1

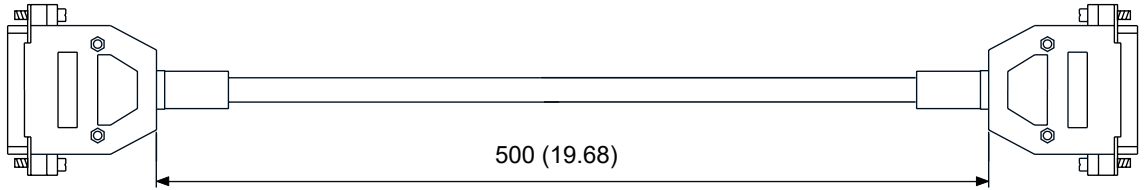

B3/B2 CN2 conversion cable
ACS3-CABDC2

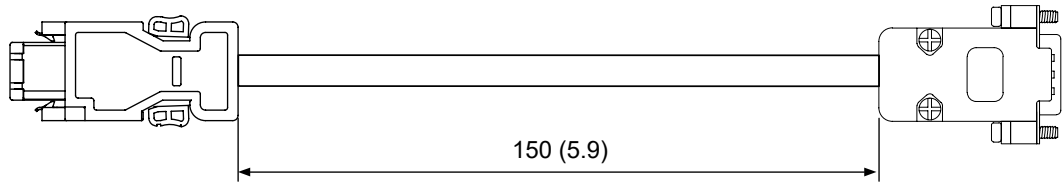

Unit: mm (inch)

CN3 RS-485/ CANopen Terminal Resistor

ACS3-CNADC3TR

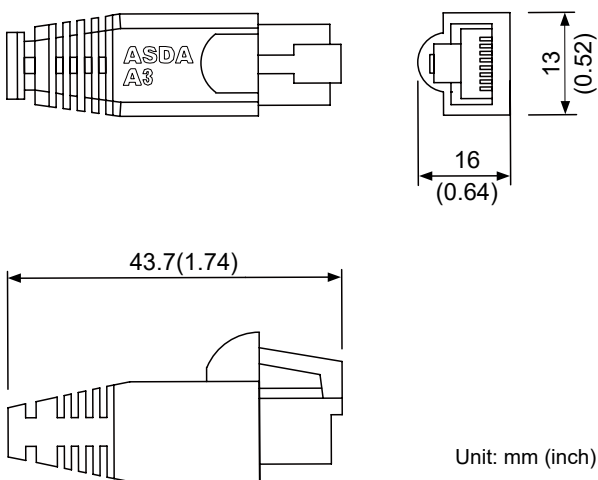

Unit: mm (inch)

CN6 DMCNET Terminal Resistor

ASD-TR-DM0008

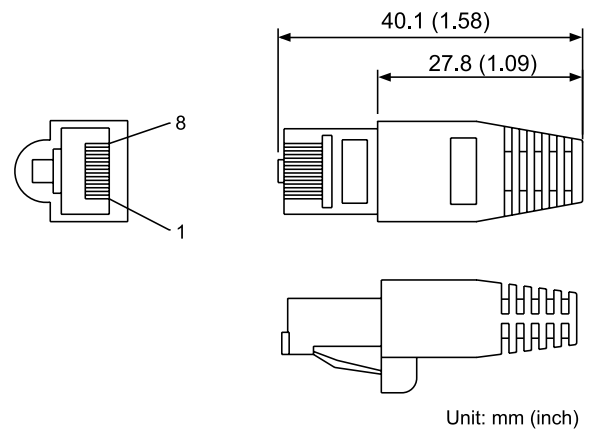

Unit: mm (inch)

Ordering Information

Accessories

CN4 Mini USB Communication Module

UC-PRG015-01B, UC-PRG030-01B

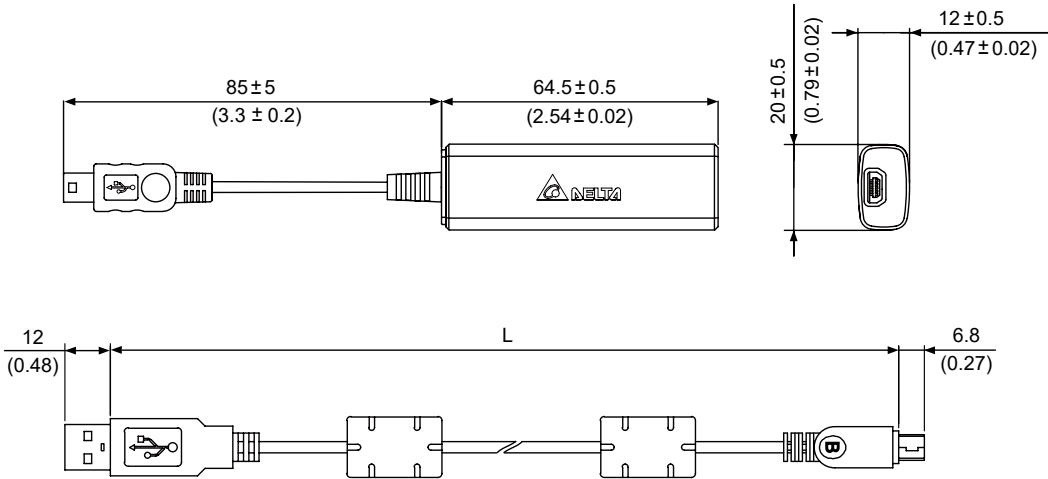

Unit: mm (inch)

Item	Part No.	L	
		mm	inch
1	UC-PRG015-01B	1500 ± 10	59 ± 4
2	UC-PRG030-01B	3000 ± 10	118 ± 4

UC-ADP01-A

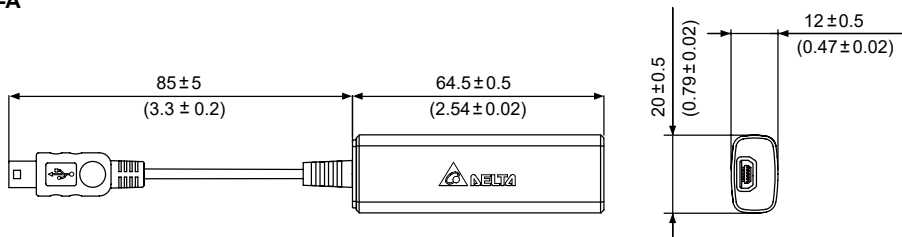

Unit: mm (inch)

UC-PRG015-01A/ UC-PRG030-01A

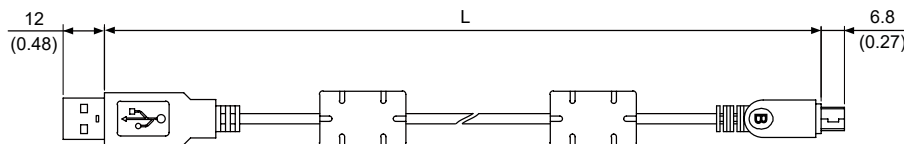

Unit: mm (inch)

Item	Part No.	L	
		mm	inch
1	UC-PRG015-01A	1500 ± 10	59 ± 4
2	UC-PRG030-01A	3000 ± 10	118 ± 4

Servo Drive Standards

Standard	ASD-B3 servo drive conforms to the highest standards and recommendations for electrical industrial control equipment (IEC, EN)
EMC Immunity	EN61000-4-6 Level 3
	EN61000-4-3 Level 3
	EN61000-4-2 Level 2 and 3
	EN61000-4-4 Level 3
	EN61000-4-8 Level 4
	EN61000-4-5 Level 3
Conducted and Radiated EMC Interference of Servo Drive	EN61800-3 Level 3 · with external EMC filter
CE Marking	B3 series servo drives have the CE marking and conform to the European Union Low Voltage Directive(2014/35/EU) and EMC Directive (2014/30/EU)
Product Certification	UL (USA); cUL (CA)
Protection Level	IEC/EN50178, IP20
Vibration Resistance Protection	20 Hz and below (1G), 20 - 50 Hz (0.6G), conforms to IEC/EN50178
Shock Resistance Protection	15 gn 11 ms; conforms to IEC/EN600028-2-27
Pollution Degree	Degree 2 conforms to IEC/EN61800-5-1